

# **FURUNO**

## **OPERATOR'S MANUAL**

### *Planning Station*

**Model**                      **PS-100**

---

(Product Name: Voyage Planning System)

**FURUNO ELECTRIC CO., LTD.**

9-52 Ashihara-cho,  
Nishinomiya, 662-8580, JAPAN

• FURUNO Authorized Distributor/Dealer

All rights reserved. Printed in Japan

A : JUL. 2023

Pub. No. OME-45190-A

(MENA ) PS-100



0 0 0 1 9 8 5 4 7 1 0

# IMPORTANT NOTICE

---

## General

- This manual has been authored with simplified grammar, to meet the needs of international users.
- The operator of this equipment must read and follow the descriptions in this manual. Wrong operation or maintenance can void the warranty or cause injury.
- Do not copy any part of this manual without written permission from FURUNO.
- If this manual is lost or worn, contact your dealer about replacement.
- The contents of this manual and equipment specifications can change without notice.
- The example screens (or illustrations) shown in this manual can be different from the screens you see on your display. The screens you see depend on your system configuration and equipment settings.
- Save this manual for future reference.
- Any modification of the software by persons not authorized by FURUNO will void the warranty.
- The following concern acts as our importer in Europe, as defined in DECISION No 768/2008/EC.
  - Name: FURUNO EUROPE B.V.
  - Address: Siriusstraat 86, 5015 BT, Tilburg, The Netherlands
- The following concern acts as our importer in UK, as defined in SI 2016/1025 as amended SI 2019/470.
  - Name: FURUNO (UK) LTD.
  - Address: West Building Penner Road Havant Hampshire PO9 1QY, U.K.
- All brand and product names, trademarks, registered trademarks, and service marks belong to their respective holders.

## How to discard this product

Discard this product according to local regulations for the disposal of industrial waste. For disposal in the USA, see the homepage of the Electronics Industries Alliance (<http://www.eiae.org/>) for the correct method of disposal.

# TABLE OF CONTENTS

---

<b>FOREWORD</b> .....	<b>vi</b>
<b>SYSTEM CONFIGURATION</b> .....	<b>ix</b>
<b>1. INSTALLATION</b> .....	<b>1-1</b>
1.1 Installation Considerations .....	1-1
1.2 Installation .....	1-1
1.3 Connection to ECDIS/RADAR .....	1-2
1.3.1 Connection status .....	1-3
1.3.2 Chart synchronization .....	1-4
<b>2. OPERATIONAL OVERVIEW</b> .....	<b>2-1</b>
2.1 License of Planning Station.....	2-1
2.1.1 How to import the license.....	2-1
2.1.2 How to renew the license .....	2-2
2.2 Touchscreen Operation.....	2-3
2.3 Graphical User Interface (GUI) .....	2-3
2.4 Sensor Information.....	2-5
2.4.1 How to select sensor source .....	2-6
2.4.2 Dead reckoning.....	2-7
2.4.3 Cursor position .....	2-8
2.5 Context Sensitive Operations.....	2-8
2.6 Cursor Pick Function.....	2-8
2.7 Orientation Mode Selections .....	2-10
2.7.1 True motion reset.....	2-10
2.7.2 Free mode function .....	2-11
2.7.3 How to change the range scale.....	2-11
2.8 Time and Time Zone .....	2-12
2.9 How to Use the Search Function .....	2-13
2.10 Setting the Color Table .....	2-15
2.11 North Mark .....	2-15
2.12 How to Shut Down or Restart the Planning Station .....	2-16
<b>3. HOW TO MANAGE CHARTS</b> .....	<b>3-1</b>
3.1 Import Charts and Updates .....	3-1
3.1.1 How to import the ENC licenses and charts into the system .....	3-2
3.1.2 How to import public key .....	3-3
3.1.3 How to check up-to-date status of charts.....	3-4
3.1.4 How to view the ENC update log .....	3-4
3.1.5 How to order chart licenses directly from the Chart Catalog.....	3-5
3.1.6 How to reconvert charts .....	3-6
3.2 Chart Catalog Legend .....	3-7
3.3 How to Delete Charts/Permits.....	3-8
3.4 How to Use filter of the Chart Catalog .....	3-11
3.4.1 How to view a list of charts for a route .....	3-11
3.5 How to Select Displayed Chart Objects of ENC.....	3-13
3.5.1 How to save presets for later use.....	3-14
3.6 Chart Display Settings.....	3-15

<b>4.</b>	<b>OWN SHIP .....</b>	<b>4-1</b>
4.1	Past Track of Own Ship.....	4-1
4.2	Voyage Log .....	4-2
4.2.1	How to view the Voyage Log.....	4-2
4.2.2	How to select period of time in the Voyage Log.....	4-3
4.2.3	How to export data from the Voyage Log.....	4-3
4.2.4	How to use the playback mode .....	4-4
4.2.5	Chart usage log .....	4-5
4.3	How to View Navigation Status of Own Ship.....	4-6
4.4	Vector .....	4-6
4.4.1	How to set the vector length.....	4-6
<b>5.</b>	<b>ROUTES .....</b>	<b>5-1</b>
5.1	Route Functions .....	5-1
5.2	How to Create a Route.....	5-2
5.2.1	How to get suggested speed for a route .....	5-5
5.3	Route Management.....	5-6
5.3.1	How to link a user chart with a route .....	5-6
5.3.2	How to import routes from a USB flash memory .....	5-7
5.3.3	How to export routes to a USB flash memory .....	5-8
5.3.4	How to check a route.....	5-9
5.3.5	How to save a route .....	5-10
5.3.6	How to delete a route .....	5-11
5.4	How to Edit a Route.....	5-11
5.4.1	How to edit an existing route .....	5-11
5.4.2	How to edit multiple routes .....	5-12
5.4.3	How to set route-related parameters.....	5-13
5.5	Monitor a Route.....	5-14
5.5.1	How to start route monitoring .....	5-14
5.5.2	How to select ETA for a waypoint .....	5-16
5.5.3	How to calculate ETA with different speed profiles .....	5-16
5.5.4	How to stop monitoring a route .....	5-17
5.5.5	How to see a list of waypoints used in the monitored route .....	5-17
5.5.6	How to edit the monitored route .....	5-17
5.6	Route Optimizing (Option).....	5-18
5.6.1	How to optimize a route.....	5-18
5.6.2	Additional route optimization information .....	5-20
<b>6.</b>	<b>USER CHART .....</b>	<b>6-1</b>
6.1	Create User Charts.....	6-1
6.1.1	How to create objects for user charts.....	6-1
6.1.2	How to delete an added object.....	6-5
6.1.3	How to add a document to a user chart object.....	6-6
6.1.4	Context menu on the user chart object list.....	6-7
6.1.5	Alert settings.....	6-8
6.1.6	Radar settings .....	6-9
6.1.7	Scale display on the ECDIS to the object.....	6-10
6.2	How to Manage User Charts .....	6-10
6.2.1	How to select a user chart.....	6-10
6.2.2	How to save a user chart.....	6-11
6.2.3	How to delete a user chart .....	6-12
6.2.4	How to switch between editing a route and a user chart.....	6-12

<b>7. TARGETS</b> .....	<b>7-1</b>
7.1 Introduction .....	7-1
7.2 Target Symbol Display Settings .....	7-2
7.3 Tracked Targets .....	7-3
7.4 AIS Targets .....	7-4
7.5 Target List .....	7-5
7.6 AIS Safety Messages.....	7-6
<b>8. TOOLS</b> .....	<b>8-1</b>
8.1 EBL/VRM .....	8-1
8.1.1 How to activate EBL/VRM.....	8-1
8.1.2 How to change range unit for the VRM .....	8-2
8.1.3 Ship and ground fixed EBL/VRM .....	8-2
8.2 Divider.....	8-3
8.2.1 Divider slider function.....	8-3
8.2.2 Snap function .....	8-4
8.3 Tidal Information (Available In the Future).....	8-4
8.4 How to Lock/Unlock the Planning Station Display .....	8-8
<b>9. SYSTEM SETTINGS</b> .....	<b>9-1</b>
9.1 System Settings .....	9-1
9.1.1 Operator’s manual language settings .....	9-3
<b>10. WEATHER FORECAST</b> .....	<b>10-1</b>
10.1 How to Import Weather Data.....	10-1
10.2 How to View Weather Data .....	10-2
10.2.1 How to select the weather data file to display .....	10-2
10.2.2 Weather legend.....	10-4
10.2.3 Weather data information display.....	10-4
10.3 How to Use Weather Data Together With Route Data.....	10-5
10.4 How to Delete Weather Data .....	10-6
<b>11. RADAR OVERLAY</b> .....	<b>11-1</b>
11.1 How to Activate the Radar Overlay .....	11-1
11.2 Radar Functions.....	11-1
<b>12. DOCUMENT VIEWER</b> .....	<b>12-1</b>
12.1 How to Import Documents and Screenshots.....	12-1
12.1.1 How to view imported documents and screenshots.....	12-2
12.2 How to Export Documents and Screenshots .....	12-4
12.3 How to Edit Documents and Screenshots.....	12-5
12.4 How to Delete Documents and Screenshots .....	12-7
12.5 How to Move Documents and Screenshots .....	12-8
12.6 How to Rename Documents and Screenshots .....	12-8
12.7 How to Copy Documents and Screenshots .....	12-9
<b>13. POSITION FIXING</b> .....	<b>13-1</b>
13.1 Position Fixing by Sensor.....	13-1
13.2 How to Fix Position Manually .....	13-2
13.2.1 Pointing by cursor on chart .....	13-2
13.2.2 Using Line of Position (LOP).....	13-3
13.2.3 Using radar echo.....	13-7
13.3 Label Display Settings.....	13-8
13.4 Position Offset.....	13-8

- 14. MAINTENANCE AND TROUBLESHOOTING..... 14-1**
  - 14.1 Troubleshooting..... 14-1
  - 14.2 Diagnostics ..... 14-2
    - 14.2.1 NMEA data export ..... 14-2
    - 14.2.2 System log export..... 14-3
  
- APPENDIX 1CONTEXT MENUS.....AP-1**
  
- SPECIFICATION(S)..... SP-1**
  
- INDEX ..... IN-1**

# FOREWORD

---

## A Word to the Owner of the PS-100

Congratulations on your choice of the Planning Station (PS-100).

Since 1948, FURUNO Electric Company has enjoyed an enviable reputation for innovative and dependable marine electronics. This dedication to excellence is furthered by our extensive global network of agents and dealers.

This equipment is designed and constructed to meet the rigorous demands of the marine environment. However, no machine can perform its intended function unless installed, operated and maintained properly. Please carefully read and follow the recommended procedures for operation and maintenance.

We would appreciate feedback from you, the end-user, about where we are achieving our purposes. Thank you for considering and purchasing FURUNO equipment.

## Features

The Planning Station provides a wide variety of navigation functions on large, high resolution (4K, 3840 x 2160 pixels) touch screens. The available screen sizes are 32-, 43- and 55-inch.

Main features of the Planning Station:

- Displaying ENC charts
- Displaying own ship symbol on chart
- Displaying Tracked Targets (TT) and AIS targets
- Route planning and monitoring
- Weather information layer
- Document viewer
- Sharing route information with FURUNO ECDIS FMD-3xxx\*. Availability depends on software version in the FMD-3xxx. Contact your FURUNO dealer about suitable software versions.

\*: FMD-3xxx refers to the FMD-3005, FMD-3100, FMD-3200(BB) and FMD-3300. In some cases ECDIS denotes these models.

- Displaying of sensor information received from ECDIS (when connected with FMD-3xxx).
- Synchronization of ENC charts (when connected with FMD-3xxx).

## Open source software

This product includes software to be licensed under the GNU General Public License (GPL), GNU Lesser General Public License (LGPL) BSD, Apache, MIT and others. The program(s) is/are free software(s), and you can copy it and/or redistribute it and/or modify it under the terms of the GPL or LGPL as published by the Free Software Foundation. Please access to the following URL if you need source codes:

[https://www.furuno.co.jp/en/contact/cnt\\_oss\\_e01.html](https://www.furuno.co.jp/en/contact/cnt_oss_e01.html)



## Reverse engineering

Reverse engineering (disassemble, decompile) of the software of this equipment is strictly prohibited. However, reverse engineering is permitted under the following conditions:

- The library used for the reverse engineering (GNU Library General Public License Version 2, GNU Lesser General Public License Version 2.1, or later editions) is clearly noted.
- The reverse engineered software is used only within the scope outlined under the appropriate license.

## Usage precautions

- When a software update becomes available, do the update within 30 days. Depending on the contract, if the software is not updated within 30 days, the system will become inoperative. However after the renewal procedure is completed the system becomes operative.
- Run a virus check before using any USB flash memory.
- Use a USB flash memory formatted to FAT16/32. NTFS format cannot be used.
- Only one external media can be connected to an USB port.
- When the equipment is used in a dusty environment, take appropriate measures to protect the equipment from dust.
- Do not connect the LAN port of this device to the onboard network.
- Adjust the brightness of the touch monitor from the monitor. The brilliance cannot be adjusted from the PS-100. Refer to the monitor's manual for the brilliance control.
- For parts that must be replaced periodically, do the replacement before the expected replacement date, to ensure stable operation of the equipment.
- Do not place anything heavy on the touchscreen surface.
- Do not get the touchscreen surface wet. Water on the surface can result in malfunction.
- Do not connect undesignated processor or other devices to the network where the PS-100 and ECDIS are connected, to avoid operation errors.
- This equipment only supports AVCS charts (ARCS and CMAP charts are not supported).
- Use a DVD drive to update charts (Recommended: DVSM-PLV8U2-BKB, BUFFALO).

## **Data Transfer with FURUNO ECDIS/RADAR**

Certain data can be transferred between the Planning Station and ECDIS/RADAR. Data is transferred through the HUB-3000 where the Planning Station and ECDIS/RADAR are connected. Up to 300 routes and 200 usercharts can be transferred when connected to the ECDIS/RADAR (however, even if the limitation is exceeded, routes and user charts can still be saved to the Planning Station side). The following data can be transferred:

Two-way data transfer (the Planning Station, ECDIS/RADAR):

- Charts
- Routes\*
- User charts

\*: If the [Speed Kn] value of any waypoint is [Null] (=not set), the [Speed Kn] of all waypoints on the Planning Station side will be shown as [Null] when synchronized to ECDIS/RADAR. In addition, alert parameters of routes will not be synchronized.

One-way data transfer (from ECDIS/RADAR to the Planning Station):

- Vessel outline dimensions
- Sensor information used by ECDIS
- Radar overlay Information

One-way data transfer (from Planning Station to ECDIS/RADAR):

- Position fix

# SYSTEM CONFIGURATION

This equipment is comprised of the components shown in the illustration below. Note that only the software (USB dongle ENC-KEY-C) is provided by FURUNO.

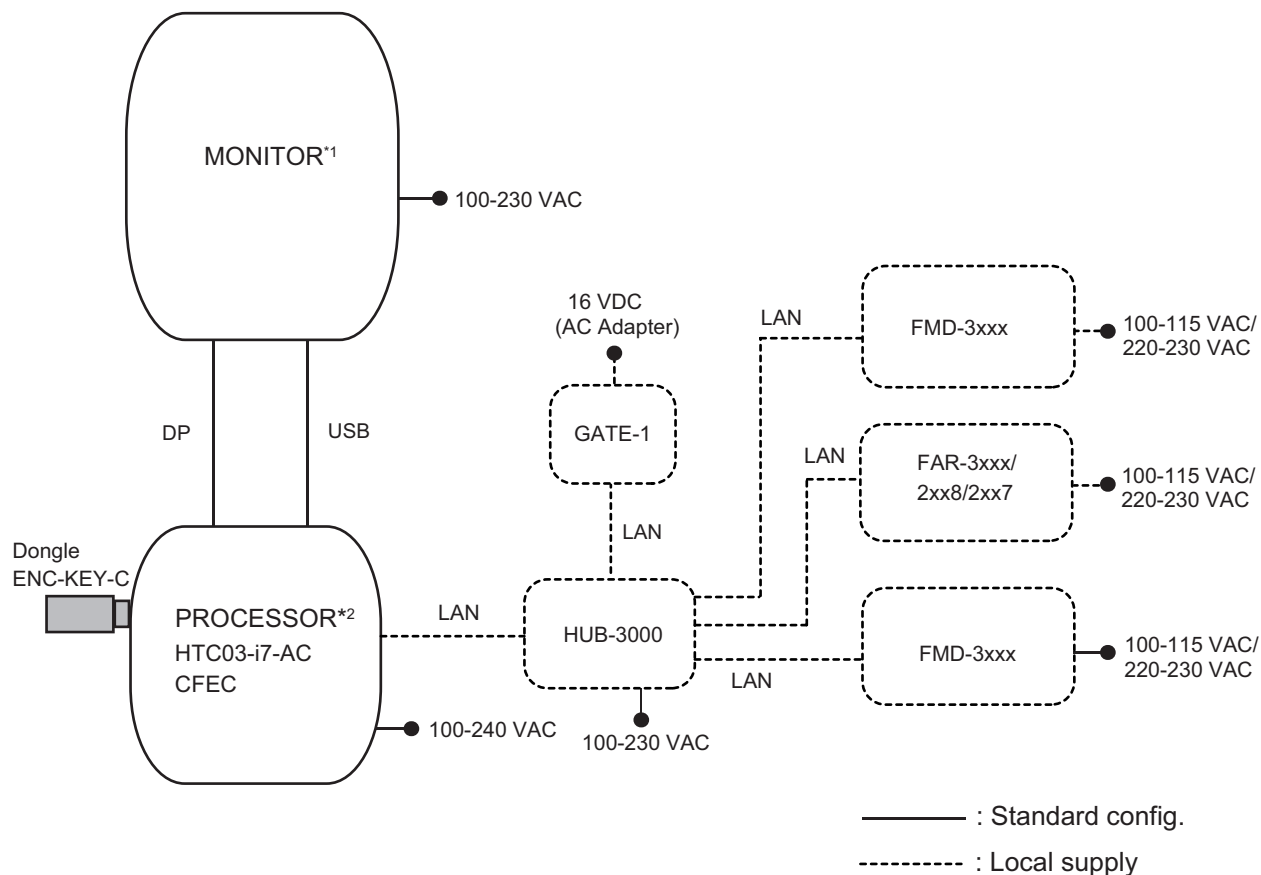

**Note:** Synchronization is not available with FCR-2xx9. Routes and user charts are not available when a FCR-2xx9 is installed in the same network as this equipment.

\*1: See below table for the recommended monitor models.

Maker	Model	Description
Hatteland Technology	HD55T22 FUD-AA4-TOGP	55 inch, 4K Tilt Model
	HD55T22 FUD-AA4-LOGP	55 inch, 4K Floor Tilt Model
	HD55T22 FUD-AA4-AOGP	55 inch, 4K Wall Mount Model
	HD55T22 FUD-AA4-COTP	55 inch, 4K Console Model
	HD43T22 FUD-MA4-COTP	43 inch, 4K Console Model
	HD32T22 FUD-MA4-AOGP	32 inch, 4K Wall Mount Model

\*2: The recommended processor model is as follows.

- HTC03-i7-AC CFEC (Hatteland Technology)

This page is intentionally left blank.

# 1. INSTALLATION

---

## 1.1 Installation Considerations

### Network installation considerations (for PS-100 and ECDIS/RADAR)

- Turn off the multi cast function when using the HUB-3000.
- Do not connect with the ship's LAN network (other networks). Also connect only the designated processor to the network (except temporary connections during maintenance and installation).

### Other installation considerations

- Observe the compass safety distance to prevent deviation of a magnetic compass.
- Install the touch monitor and processor according to the manufacturer's installation manual.
- Use only the designated display cables and USB cables provided with each unit.

## 1.2 Installation

Carry out the following procedure to connect required cables before starting the operation of the Planning Station.

**Note:** Only the software and dongle are provided. The required processor, monitor and cables for the operation are supplied as option.

1. Connect the dongle to the USB port on the processor.
2. Connect the DisplayPort cable between the adapter in the processor and the DisplayPort of the monitor.
3. Connect the USB cable between the processor and the monitor (cable is for touch screen operation).
4. Connect the power cables of the processor and monitor.
5. Check the following settings on the display settings menu in the monitor.

**Note:** The following settings are for the recommended Hatteland Technology monitor model only. Check the appropriate settings for other monitor models.

- Input source settings: Main Input - Display Port
- Communication: USB
- Color Mode Settings: Gamma - Calibration DisplayPort

6. Check that the touch monitor has correct resolution when the Planning Station software is running (3840 × 2160 pixels). Refer to the Installation Instructions "3. Display Settings" to set the resolution.
7. Connect the LAN cable between the Planning Station processor and HUB-3000 to get two-way data transfer with the FURUNO ECDIS/RADAR (when FMD-3xxx is available).  
**Note:** When the parameters are set on the ECDIS/RADAR side, connect the ECDIS/RADAR to the Planning Station.
8. Gate-1 is an optional chart provider service and connects to the HUB-3000.  
For more information contact your local FURUNO dealer.

## 1.3 Connection to ECDIS/RADAR

### Introduction

The Planning Station and ECDIS/RADAR can be connected to the Local Area Network (LAN). See chapter 9 for further information. The Planning Station is configured to conduct two-way data transfer between itself and the No.1 ECDIS through HUB-3000. The following information is transferred.

Two-way data transfer:

- Charts
- Routes <sup>\*1\*2\*3\*4</sup>
- User charts <sup>\*1\*5</sup>

One-way data transfer (from the ECDIS/RADAR to the Planning Station):

- Vessel outline dimensions
- Sensor information (for ECDIS)
- Radar overlay information <sup>\*6</sup>

One-way data transfer (from the Planning Station to the ECDIS/RADAR):

- Position fix

<sup>\*1</sup>: Max. 300 routes and 200 user charts can be synchronized to FMD-3xxx.

<sup>\*2</sup>: The instant tracks created on the ECDIS side cannot be synchronized to Planning Station. If there are Instant Tracks stored on the ECDIS side, the number of routes that can be synchronized from the Planning Station to the ECDIS will be the number minus the stored ECDIS instant track number (for example: if 10 instant tracks are stored on the ECDIS side, the number of routes that can be synchronized from Planning Station to the ECDIS will be 290 (from max. 300)).

<sup>\*3</sup>: Up to 1000 destinations can be synchronized from the Planning Station to ECDIS and the Planning Station can store more than 1000 destinations. However, destinations exceeding 1000 will not be synchronized to the ECDIS.

<sup>\*4</sup>: File editing may cause the following route settings to reset to their default values.

- On the Planning Station side: ETD/ETA, DST settings (displayed as blank).
- On the ECDIS side: Highlighted check settings (ON/OFF) of [Alert Parameters] tab in [Route Plan] window.

<sup>\*5</sup>: When synchronizing user charts to the ECDIS, description up to 499 characters and 50 lines can be synchronized. When the limit is exceeded, the description is saved on the Planning Station side but will not be synchronized to the ECDIS.

**Note:** Symbols can be added. However, if the language setting is set as English on the ECDIS side, the symbols are replaced and displayed as [\*]. Note that symbols can be added only for user chart descriptions.

<sup>\*6</sup>: The radar image from the FAR-2xx7 can only be displayed when connected to FMD-3xxx.

See the table below for the compatible ECDIS/RADAR models to connect to the Planning Station.

A: Data synchronization with device.

B: Data from the Planning Station synched with the connected device.

C: Data from connected device synched with the Planning Station.

D: No data synchronization with connected device.

Function	Model for connection			
	FMD-3xxx	FAR-3xxx	FAR-2xx8	FAR-2xx7
Route	A	A	D	D
User chart	A	A	D	D
Chart	A	A	D	D
Vessel outline dimensions	C	C	D	D
Sensor information	C	C	D	D
Radar overlay information	C <sup>*1</sup>	C	C <sup>*2</sup>	C <sup>*3</sup>
Position fix	B	B	D	D
Voyage log	B	B	D	D

\*1: Requires FAR-2xx7/FAR-2xx8.

\*2: Requires FMD-3xxx.

\*3: Requires FMD-3200.

### 1.3.1 Connection status

Connection status for route and user chart can be seen on the route selection or User chart selection window. Tap the [Route] or [User chart] button and tap [Select] to show the window. "Connected to FMD" is shown in green characters when the connection is normal; "No FMD connection" is shown in red characters when the connection is lost.

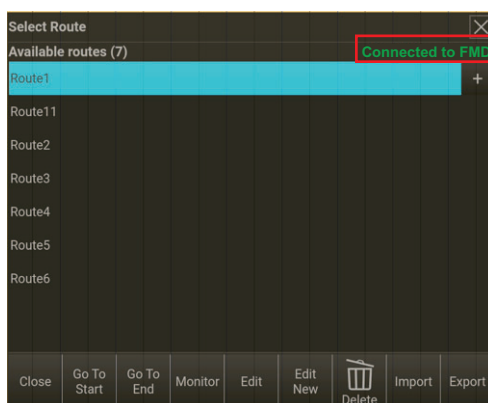

Connection OK

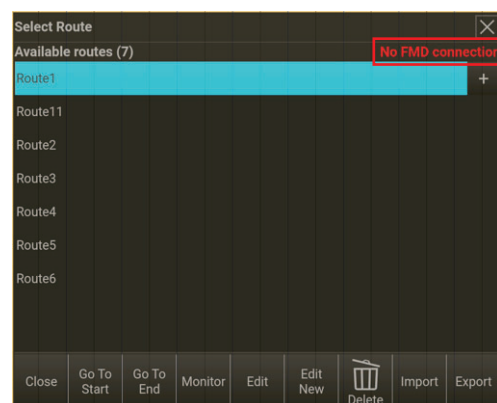

Connection lost

**Note:** If the connection is lost, check the LAN connection to the HUB-3000 and from the HUB-3000 to the FMD-3xxx (No.1 ECDIS).

# 1. INSTALLATION

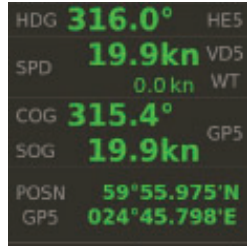

Sensor information received from ECDIS

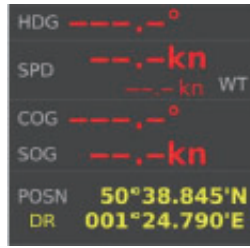

Sensor information not received from ECDIS

Status	Description
No FMD Connection	Not connected with ECDIS/RADAR.
Connected to FMD	Connected with ECDIS/RADAR.
Connected to FMD (has conflicts!)	Partly connected with ECDIS/RADAR (error occurs).
Synchronizing with FMD	Synchronizing with ECDIS/RADAR is in progress.

**Note:** If a conflict occurs during the synchronization of route/user chart, the corresponding file will be shown in yellow. Tap the file in the [Select Route] or [Select Userchart] window and then tap the [Resolve Conflict] button. When the [Conflict Resolution] window appears, Select from the following options to resolve the conflict if necessary.

Options	Description
Keep latest version (recommended)	Discard the old file and keep the latest file.
Keep PS-100 version	Discard the ECDIS/RADAR file and keep the PS-100 file.
Keep other workstation version	Discard the PS-100 file and keep the ECDIS/RADAR file.

## 1.3.2 Chart synchronization

Charts are automatically synchronized when connected to the FMD-3xxx.

### How to check sync status/peer status from the Planning Station

Carry out the following procedure to view the status of chart synchronization.

1. Tap the [Chart] button and select [Manage Charts].
2. Tap the [Settings] button and select [Chart Sync] to open the following window.

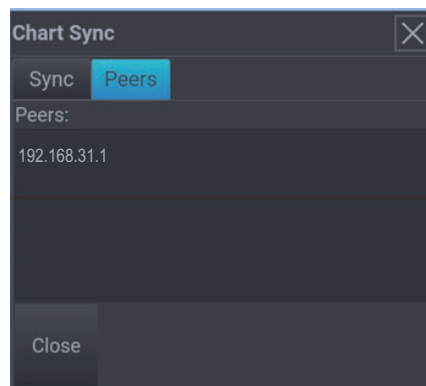
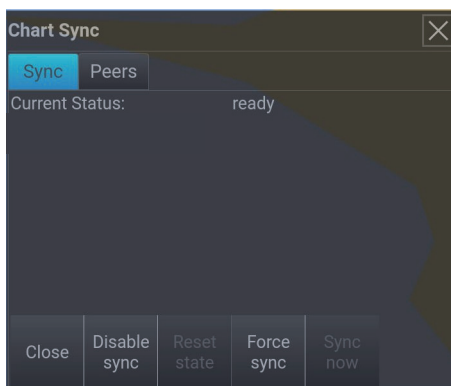



**[Sync] tab**

The current chart sync status appears.

- [Close]: Close the window and finish.
- [Disable sync]: Disable synchronization or cancel import of charts from FMD-3xxx. When tapped, the label on the button shows [Are you sure?]. Tap the button within five (5) seconds to disable.
- [Reset state]: Reset the current status from "must send" or "must receive" to "ready".
- [Force sync]: Force chart synchronization.
- [Sync now]: Start chart synchronization.

**[Peers] tab**

The current synchronization status and IP address of the connected device are shown. If the device is offline, [Offline] is shown after the IP address and the address is displayed in red (see below).

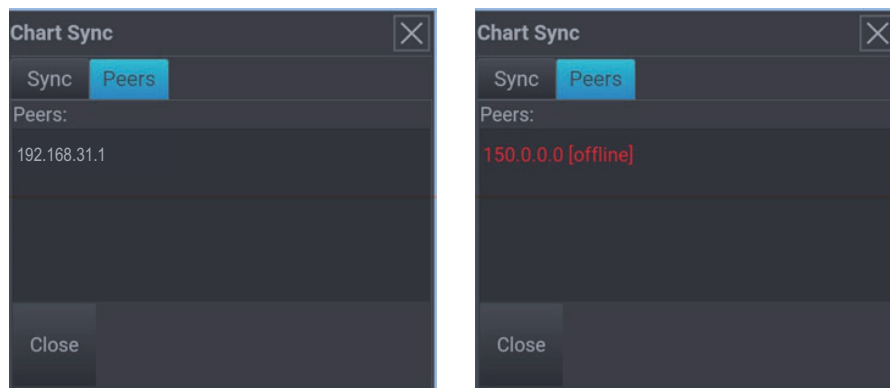
**Settings on FMD-3xxx**

Select the unit to sync with the Planning Station, FMD-3xxx or Chart Radar. This can be done with [Sync Config] in the [Installation Parameters] menu, as shown in the figure below.

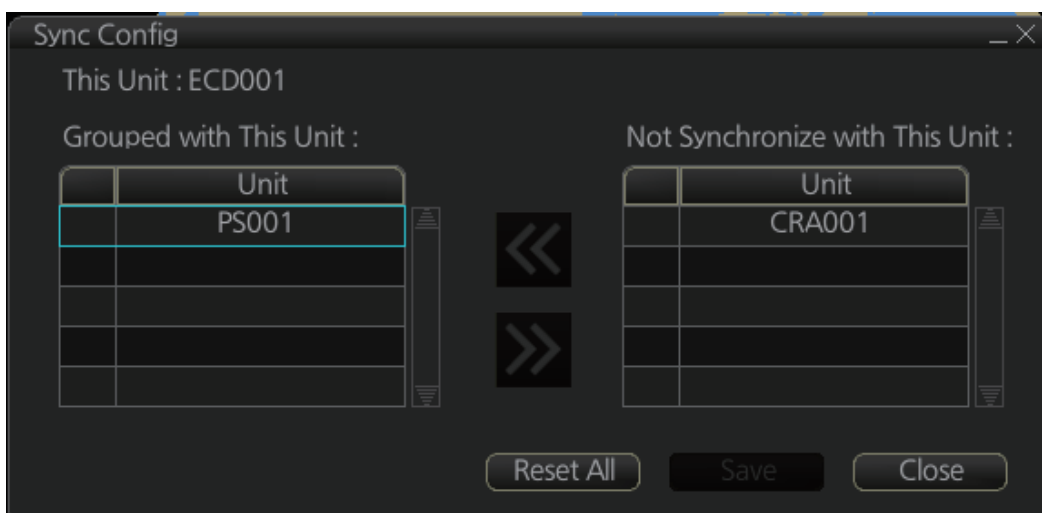

## 1. INSTALLATION

This page is intentionally left blank.

## 2. OPERATIONAL OVERVIEW

### 2.1 License of Planning Station

#### 2.1.1 How to import the license

A license is required to use the Planning Station. To import the license into the Planning Station, do as follows.

1. Insert the USB flash memory with downloaded license file to the USB port.
2. Tap the [System] button.
3. Tap the [Settings] button and select the [License] tab to open the following window.

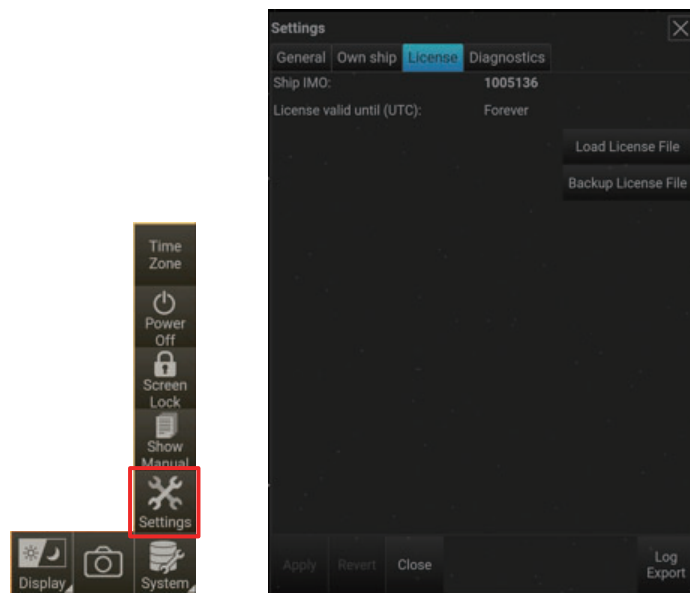

4. Tap the [Load License file] button.

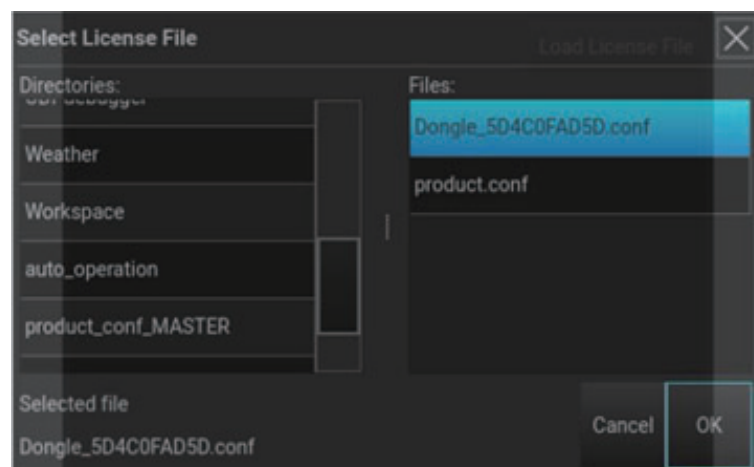

## 2. OPERATIONAL OVERVIEW

5. Select the file to load and tap the [OK] button. When the installation of the files is completed, The message "License file is installed successfully. System restart required" appears.

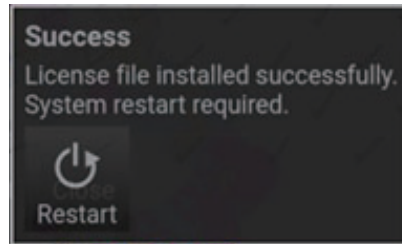

6. Tap the [Restart] button to restart the system to complete the installation.

### 2.1.2 How to renew the license

When the message "The license of this software will expire after xx days" appears at the upper right corner, it is time to renew the license. Contact your local FURUNO dealer for a new license file (to be downloaded to a USB flash memory) and then carry out the procedures explained in subsection 2.1.1.

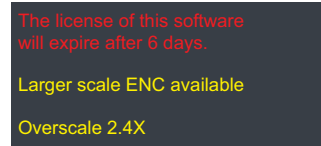

When the license has expired, the message shown below appears. All functions except the following are disabled.

- [System] button - [Settings] window
- Power ON/OFF

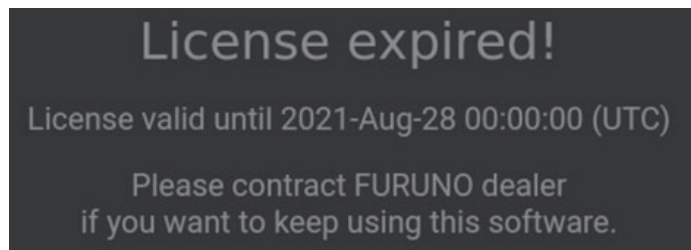

When the license cannot be found on the system, the following message appears. Contact your local FURUNO dealer.

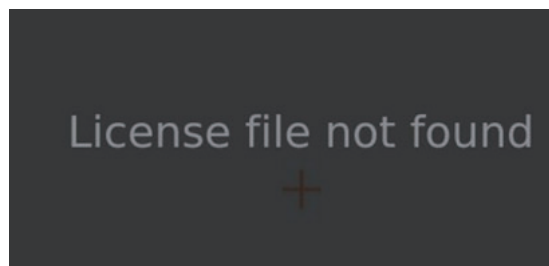

## 2.2 Touchscreen Operation

Operation with finger	Description
Tap	Tap objects and buttons to select menu items and to turn menu items ON/OFF.
Long tap	Tap and hold object more than 1s to select menu items. Mainly used to show context menus.
Double tap	Mainly used to open documents, on the [Document Viewer] screen (see chapter 12).
Pinch	Zoom the chart scale in or out.
Drag	Drag objects; scroll the screen.
Flick	Flick charts and lists on the screen.

## 2.3 Graphical User Interface (GUI)

The following information/operations are available in addition to chart presentation.

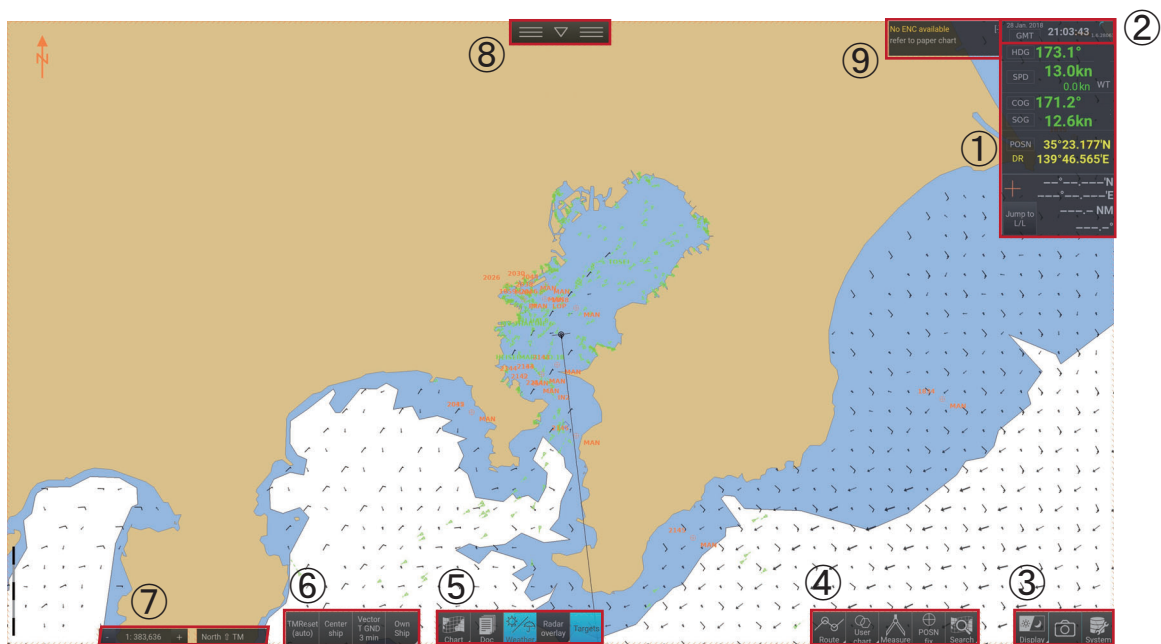

*User interface*

No.	Description
①	Sensor Information- heading, speed, position and cursor position.
②	Time and time zone.
③	Display palette, screenshots, system restart/shutdown and system software update operations.
④	Route and user charts operations, measuring tool, search operation and position fixing operations.
⑤	Chart loading functions, document viewer, weather forecast display functions, tidal (when connected to ADP server, see section 8.3), radar overlay and targets (AIS & TT) functions.
⑥	Buttons to operate own ship presentation/orientation, speed vector, past tracks and voyage log.
⑦	Chart scale and orientation.
⑧	Rotate user interface 180 degrees.

## 2. OPERATIONAL OVERVIEW

⑨	<p>Warning indication box*. (chart related warnings/ diagnostics information/ license expiration/ data conflicts)</p> <p><b>Note:</b> When the Gate-1 chart provider is connected and new charts become available, the message "New charts available at Gate-1" appears.</p>
---	--

\*: Below information is shown in the warning indication box. If any of the below information is displayed, carry out the methods described in the table to resolve the problem.

Title	Description	Remedy
Usercharts have conflicts	Conflicts in userchart(s).	Resolve the conflict with the user-chart(s).
Routes have conflicts	Conflicts in route(s).	Resolve the conflict with route(s).
Larger scale ENC available	Large scale ENC chart is available.	Adjust the chart scale as appropriate.
Overlap	Overlap with multiple charts.	-
Overscale *.*X	Chart scale is too large.	Adjust the scale.
No ENC available	No charts to display.	Install chart.
Non-ENC data	The chart is other than appropriate ENC chart.	Install the official ENC chart.
Not up to date (SSE 27)	Some or all chart cells are not updated.	Update the chart.
Permit expired (SSE 25)	Chart license is expired.	Update the chart license.
SENC version mismatch. Try reconvert	Your converted chart and the SENC version do not match.	Reconvert the chart.
Low disk space	Low available disk space.	Delete documents from the folder to increase disk space.
No connection to dongle	The dongle is not connected.	Connect the dongle to the system.
Invalid config from FMD	Vessel data received from the connected ECDIS does not match the data on this equipment.	Resolve the conflict to receive correct vessel information data from ECDIS.
The license of this software will expire after **days	The software license for the Planning Station expire in ** days.	Update the Planning Station license.
System restart required	The Planning Station system needs to be restarted.	Restart the Planning Station system.
Recording NMEA data	Recording the NMEA data.	Stop the NMEA data acquisition.
New charts available at Gate-1	New charts are now available at Gate-1.	Update the chart in Manage Charts mode.
ENC:** days until permit expiry	The permit license will expire in ** days.	-
ENC permits have expired	The permit license is expired.	Update the ENC permit.
Failed to sync routes / user charts	Routes/user chart synchronization failed.	Delete unnecessary route data.
Multiple external media	Multiple USB memories are inserted.	Insert one USB memory only.

## 2.4 Sensor Information

You can find sensor information at the upper right corner of the display.

**Note:** Available sensor information depends on the connected sensors. Sensor information is received through the Local Area Network. The Planning Station is connected to ECDIS.



Name	Description
HDG	Heading
SPD	Speed (either ground stabilized or through the water) bi-directional speed, if available from sensor.
COG	Course over the ground
SOG	Speed over the ground
POSN	Position

## 2. OPERATIONAL OVERVIEW

### 2.4.1 How to select sensor source

Tap the [HDG], [SPD], [COG], [SOG], or [POSN] button on the sensor information area and select the [Select sources] from the displayed context menu. The below [Sensor sources] window are shown.

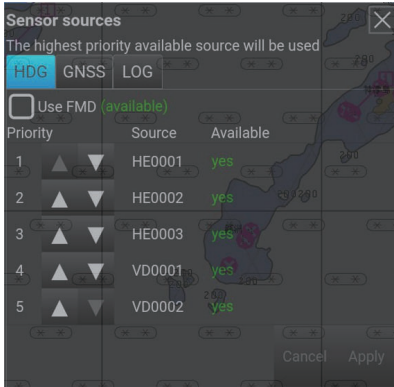

HDG tab  
(Heading sensor source)

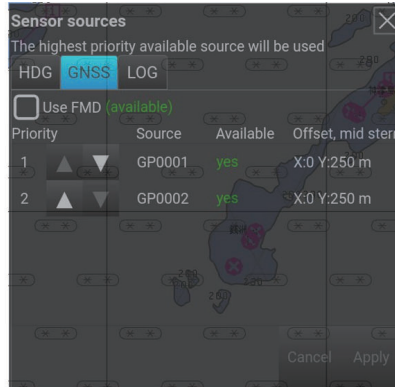

GNSS tab  
(Position-fixing source)



LOG tab  
(Speed sensor source)

**Note:** Use ▲ and ▼ to set sensor priority order. Tap the [Apply] button to confirm your selections.

When the Planning Station is connected with the FMD-3xxx, the [Use FMD] check box appears on the [Sensor sources] window as shown in the figure below. Check the box to use sensor data (in the example below, position data) from the ECDIS.

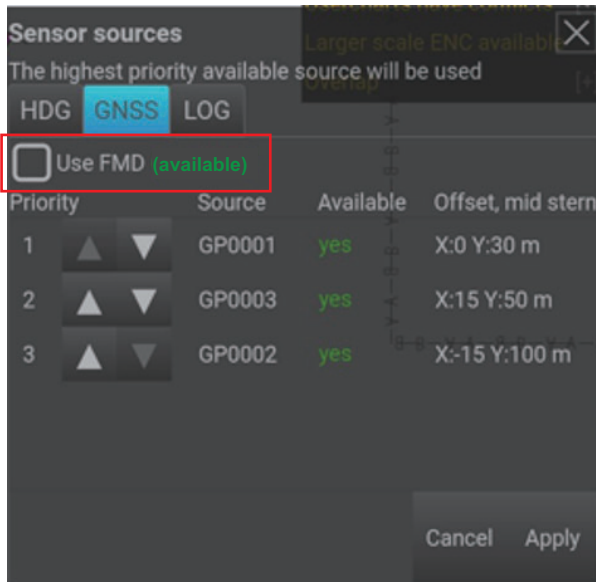

ECDIS sensor data available

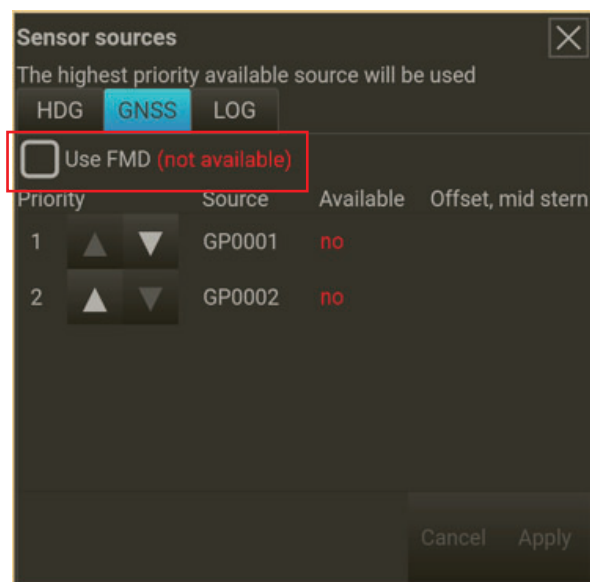

ECDIS sensor data not available



## 2.4.2 Dead reckoning

If heading, speed and/or position information is not received from sensors, values can be entered manually. Tap the sensor information area to open the context menu and select [Set Manual heading] or [Set manual speed].



**Note 1:** Uncheck the [Use FMD] check box on the [Sensor sources] window (see subsection 2.4.1) to enter values manually.

**Note 2:** See also chapter 13 for information about dead reckoning.

### Manual heading settings

1. Tap [HDG] on sensor information area and then select [Set manual Heading] to open the window shown right.
2. Enter the value and then tap the [OK] button. The window closes automatically.

**Note:** The HDG indication on the sensor information area turns yellow, and the sensor source is shown as MAN.

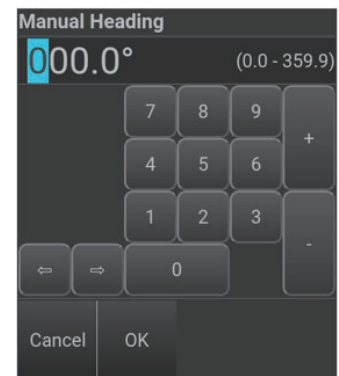

### Manual speed settings

1. Tap [SPD] on the sensor information area and then select [Set Manual Speed] to open the window shown right.
2. Enter the value and then tap the [OK] button. The window closes automatically.

**Note:** The SOG indication on the sensor information area turns yellow, and the sensor source is shown as MAN.

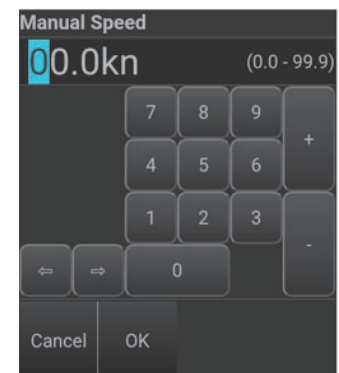

### 2.4.3 Cursor position

The screen center can be set with the cursor. Tap the [Jump to L/L] button to show the [Jump to position] window and set desired latitude/longitude values. Tap the [OK] button to set the position entered as the screen center. You can see and adjust the set position on the cursor position information window (upper right corner under the sensor information window) with range and bearing values from own ship position.

**Note:** The [Jump to position] window can also be displayed by tapping the [Jump To L/L] button in the cursor position information window.

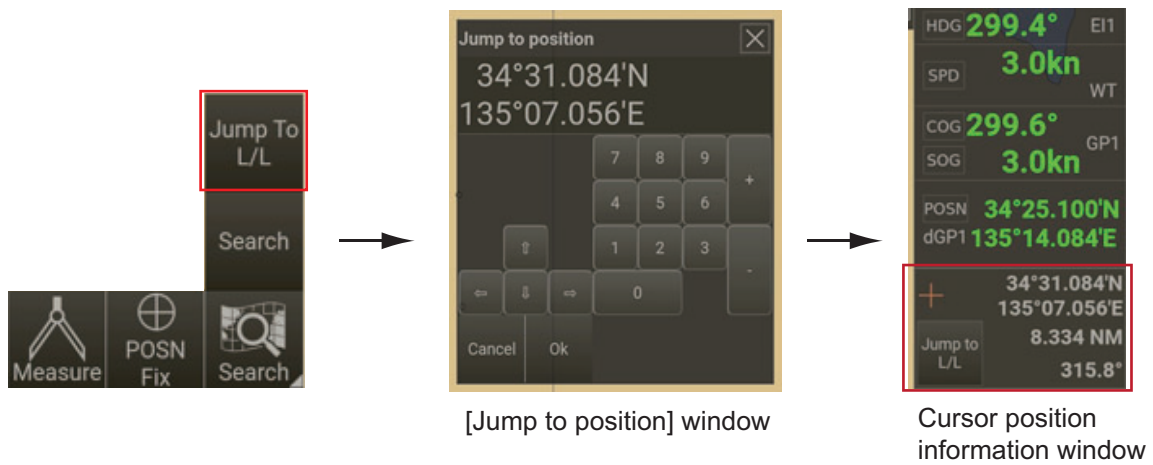

## 2.5 Context Sensitive Operations

Some operations are available by long tapping the screen. See page AP-1 for information about context menus.

## 2.6 Cursor Pick Function

The cursor pick function finds additional information about chart objects. Long tap (more than 1s) the object on the chart area, and a pop-up menu appears. You can select [Pick report] or [Chart legend] (or [Weather legend] when weather data is selected) to see the details about chart and chart objects.

**Note:** See subsection 10.2.2 for information about the [Weather legend] function.

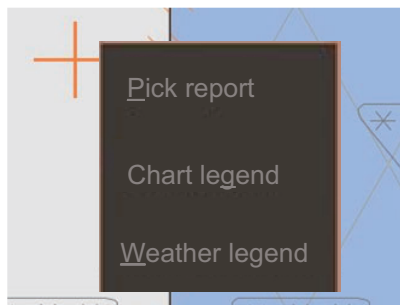

### Pick report

Tap [Pick report] to open the window shown in the figure below. All objects on the selected chart location are listed as shown in the window. Select desired object on the list to see additional information.

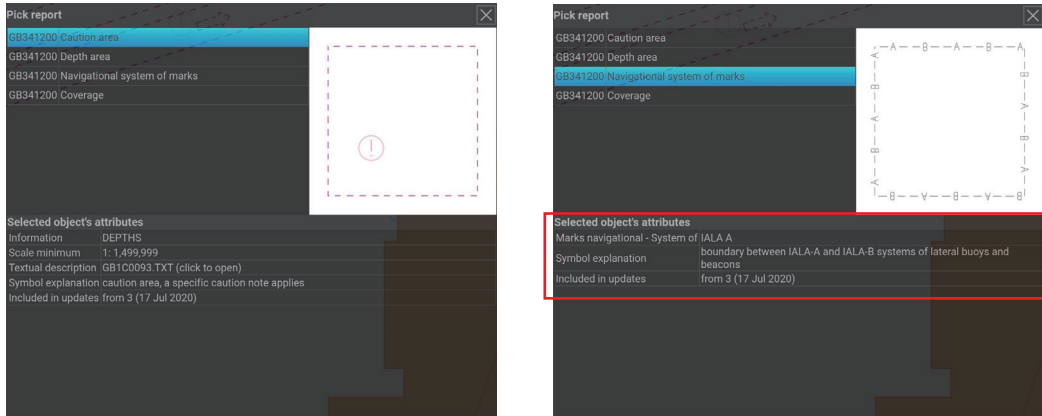

### Chart legend

Tap and hold [Chart legend] to open the window shown in the figure below. Tap [Chart legend] to see the information window. The information shows details about the chart at the cursor position.

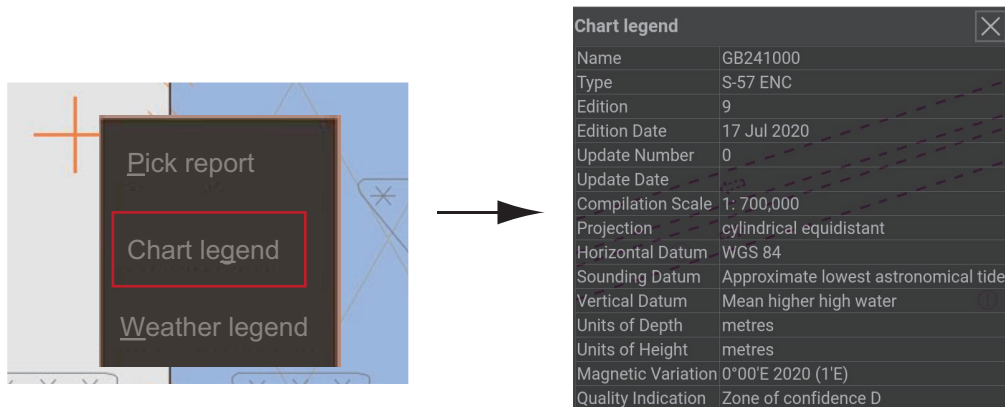

## 2.7 Orientation Mode Selections

The following orientation modes available in the Planning Station: Head Up TM, Head Up RM, North Up TM, North Up RM, Free TM, Free RM.

- North-Up: North (0°) is the top-center of the screen.
- Head-Up: Current heading is the top-center of the screen.
- Free RM/TM: See subsection 2.7.2.
- TM: True Motion. Own ship mark moves in relation to actual vessel movement. The chart is displayed in fixed orientation.
- RM: Relative Motion. Own ship mark is fixed at the center of the screen. The chart moves in relation to vessel movement.

**Note:** When TM is shown in yellow, the TM reset is disabled. When RM is shown in yellow, the chart is not relative to the own ship position.

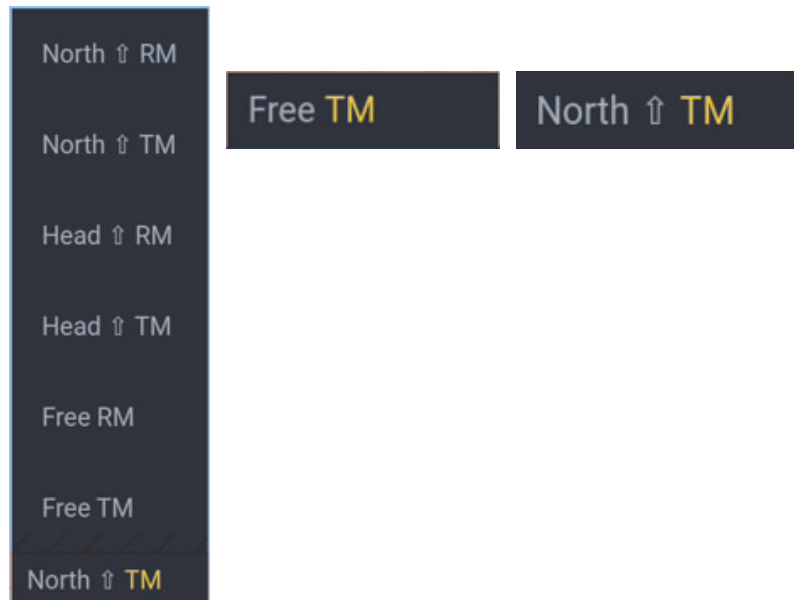

### 2.7.1 True motion reset

In the true motion mode, the chart is stationary and own ship moves on the screen. When the TM reset function is set to ON (AUTO), the chart display is updated when the own ship reaches near to the edge of the display. At this point, the own ship is automatically pulled back to the reset position. You can also tap the [TMReset] button to pull the own ship back to the reset position.

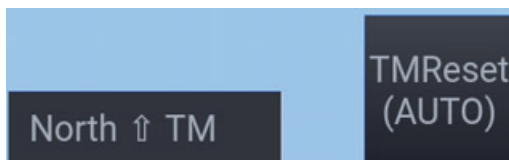

True Motion reset enabled



True Motion reset disabled

## 2.7.2 Free mode function

Select [Free TM] or [Free RM] to rotate the chart to desired direction. The value displayed in the free mode is the angle (clockwise) based on north as standard to the top of the display when the chart is tilted.

1. Tap the operation mode button.
2. Select [Free TM] or [Free RM] on the menu. A green icon appears with the rotation angle value.
3. When the icon is displayed, drag index fingers on the screen to rotate the chart as shown below.
  - Drag right index finger downward and the left index finger upward: The chart rotates clockwise.
  - Drag right index finger upward and the left index finger downward: The chart rotates counterclockwise.

**Note:** You can also set the rotation value manually. Tap and hold the free mode icon to display the [Screen Up Direction] window as shown right. Set the value and then tap the [OK] button.

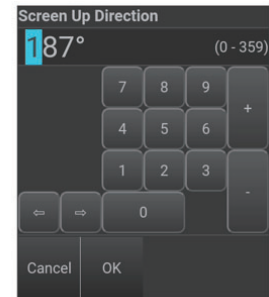

4. After the chart is rotated, tap the free mode icon to fix the chart. The color of the icon changes to red. The chart orientation is fixed and the rotation mode is disabled.
5. To re-enable the free mode rotation, tap the icon again to switch the color back to green.



## 2.7.3 How to change the range scale

You can change the range scale by the following methods.

- Tap the range scale indicator and then drag the slider bar.
- Tap [+], [-] symbol to set the range scale.
- Use the pinch operation to zoom in or out.
- Tap [Center Ship] to center the own ship on the display.



## 2.8 Time and Time Zone

Time and time zone information are available at the upper right corner. Time is automatically adjusted by the ZDA sentence transmitted by GNSS receiver, if available. If there is a discrepancy between the time in the ZDA sentence and the time on the Planning Station, the time on the Planning Station is displayed in yellow but will be adjusted automatically.

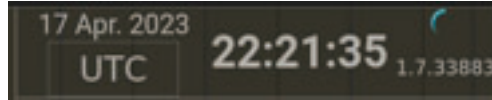

### How to select the time zone

The time zone can be toggled between local time zone and Coordinated Universal Time (UTC). Tap the time zone indication at the upper right corner to switch the time zone. For example, when the time zone is set as Japan, the switching order is as follows: UTC→JST→+09.00→ UTC...etc.



1. To change the time zone, tap the [System] button and select [Time Zone].

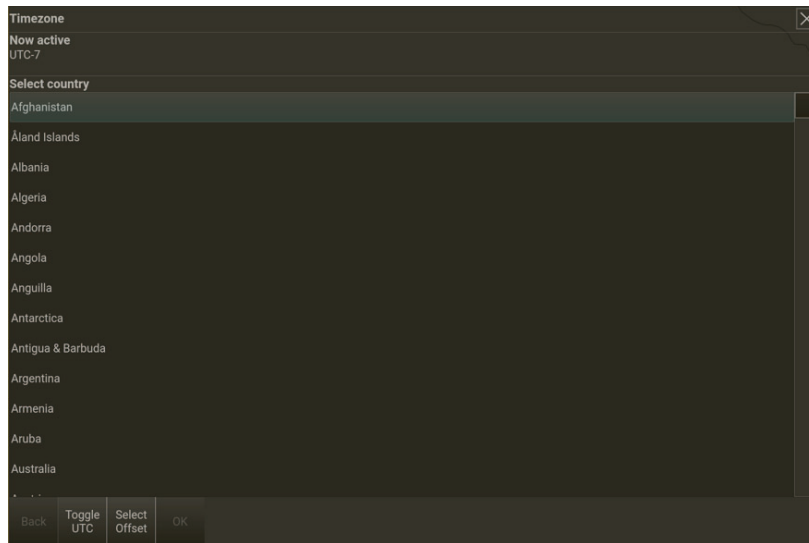

- 2. You can directly select the country from the [Select Location] button that shows the country option list, or tap the [Select Offset] button to select the time zone as shown below.

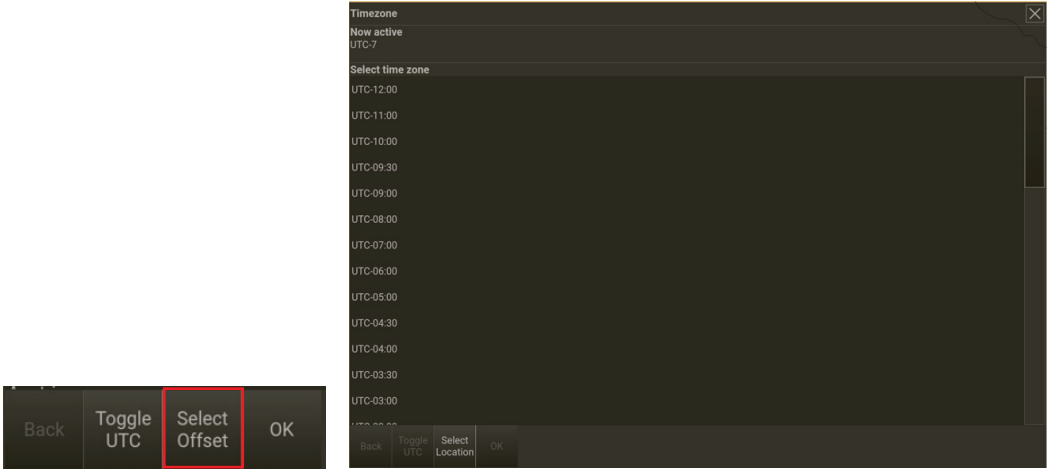

- 3. Tap the [OK] button to set the desired country or time zone.

## 2.9 How to Use the Search Function

The search function finds various object information displayed on the Planning Station. To activate search, tap the [Search] button.

### Search by name

You can search for the following data: locations, routes, user charts. You can enter multilingual multi-byte characters to search. On the software Keyboard, long-tap the following characters to enable input: a, c, e, i, l, n, o, s, u, y, z, A, C, E, I, L, N, O, S, U, Y, Z.

- 1. Tap the [Search] button to open the [Find Location] window.

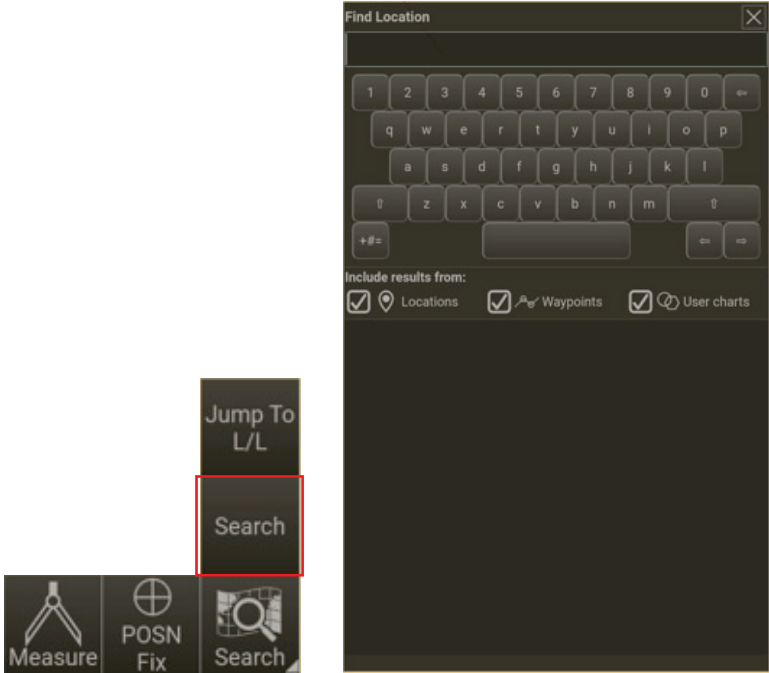

## 2. OPERATIONAL OVERVIEW

2. Type the name of the object you want to search, and the Planning Station gives suggestions to find a location.
3. If there are multiple options for the same location name, tap the arrow next to the location name to see all available latitudes/longitudes.

Tap the arrow to see available latitude/longitude for the selected location name.

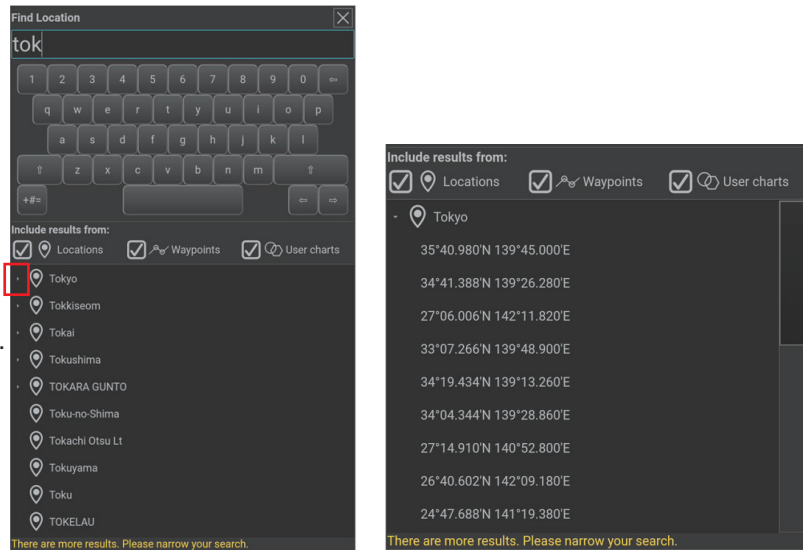

4. Tap the location to move the chart center point automatically to the selected location. You can filter the results using the checkboxes. For routes (including waypoints) and user charts (including user chart objects), tap the desired result and to show [+] on the right side of the result name and then tap to select the route or user chart.

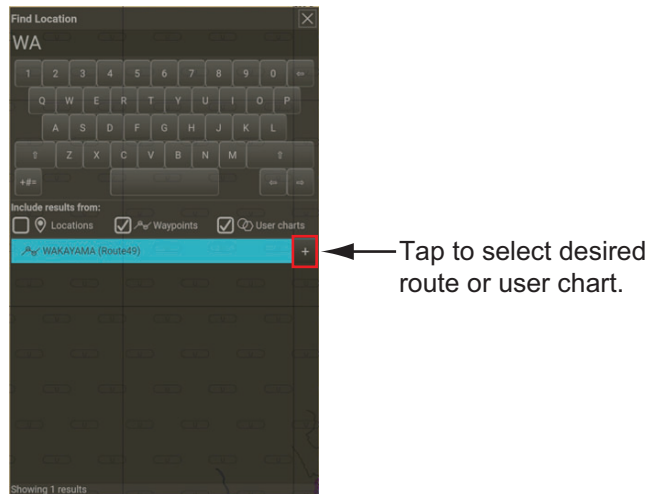

### **Search by position**

You can find locations by entering latitude and longitude values on the [Jump to position] window. See subsection 2.4.3 for more information.



## 2.10 Setting the Color Table

Tap the [Display] button to select the color table to use. The choices are [Day], [Dusk] or [Night]. The activated button is highlighted in blue color.

**Note:** Adjust the brilliance of the touch monitor at the monitor. The brilliance for the monitor cannot be adjusted from the PS-100. Refer to the monitor's manual for how to adjust the brilliance.

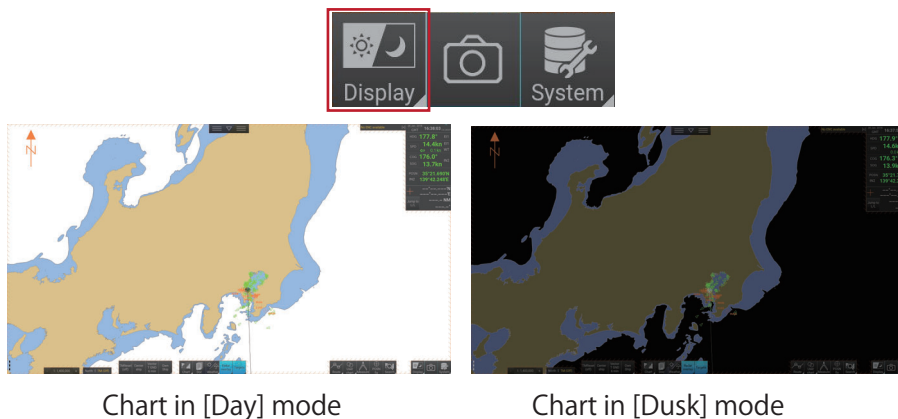

## 2.11 North Mark

The north mark appears at the top left corner when the radar overlay is active. The north mark is always visible and points in the northerly direction. At high latitudes where north is not in a set direction, the north mark appears with the text “at own ship” or “at center” below the mark to show the reference point.

- “at own ship“: Shown when your vessel is displayed on-screen. North is shown with your vessel as the reference point.
- “at center“: Shown when your vessel is not displayed on-screen. North is shown with the center of the screen as the reference point.

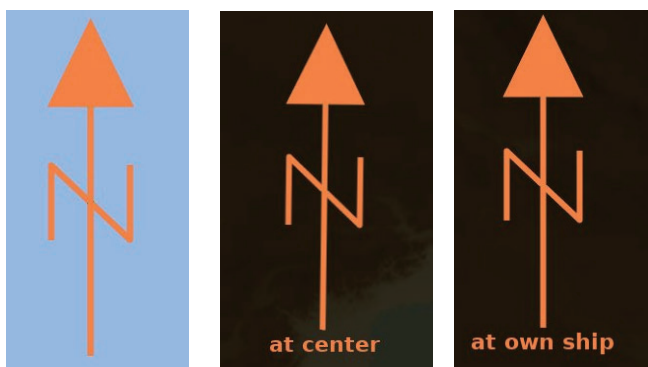

## 2.12 How to Shut Down or Restart the Planning Station

To shut down or restart the system, tap the [System] button at the bottom corner of the screen and the tap desired button (See the figure below).

- [Power Off]: Shut down the system.
- [Restart]: Restart the system.
- [Cancel]: Cancel the operation.

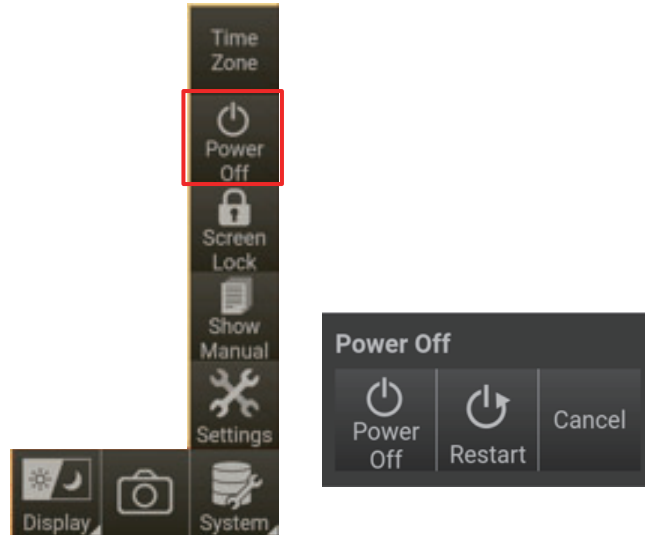

# 3. HOW TO MANAGE CHARTS

## 3.1 Import Charts and Updates

### Chart Catalog

The [Manage Charts] mode is a graphical interface that provides access to chart maintenance functions. Frames are displayed according to chart coverage area. The color of a frame indicates chart status within the frame. Tap the [Chart] button and select [Manage Charts] to go to the [Manage Charts] mode and display the Chart Catalog.

**Note:** Do not edit or monitor a route in the [Manage Charts] mode.

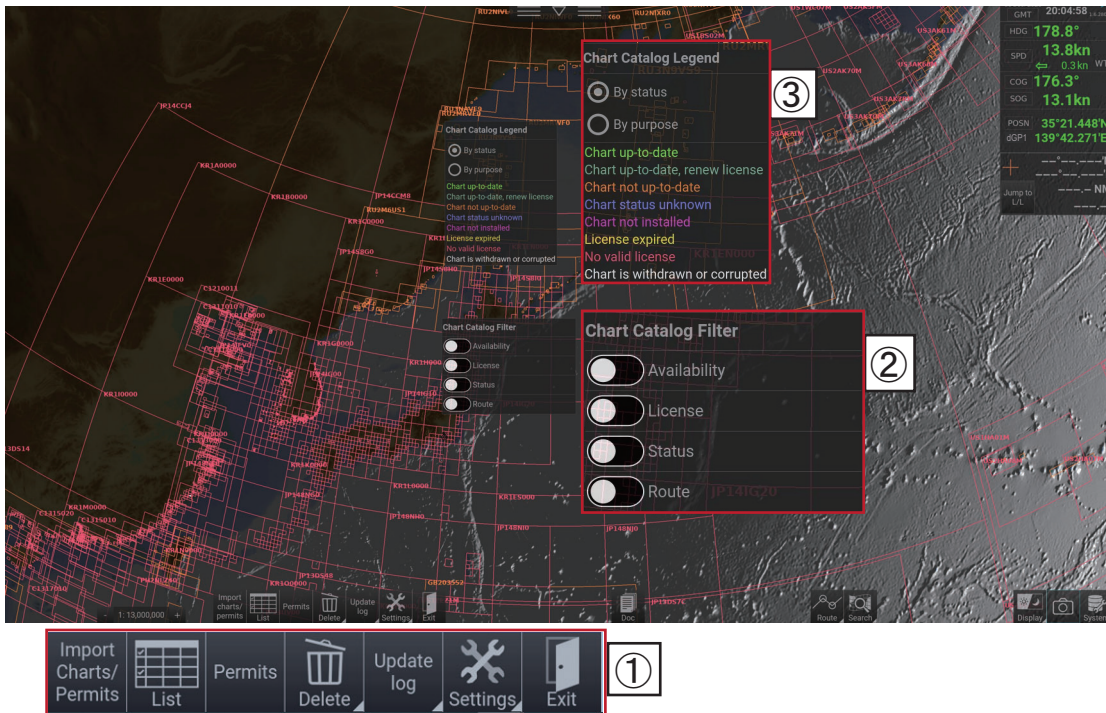

No.	Description
①	Chart importing related functions.
②	Filter for Chart Catalog display.
③	Legend

### 3. HOW TO MANAGE CHARTS

#### 3.1.1 How to import the ENC licenses and charts into the system

ENC licenses (permits) and charts can be installed from the [Manage Charts] mode (see previous page for details), using optional Gate-1 or the external USB flash memory. Charts can also be installed from a DVD drive.

**Note:** Do not use other functions during the chart installation.

1. Connect the USB flash memory where the ENC license and/or charts are stored to the Planning Station.
2. Tap the [Chart] button and select [Manage Charts] to go to the [Manage Charts] mode.
3. Select [Import Charts/Permits] at the bottom of the display. The [Confirm update] window appears.
4. In case of using Gate-1 for importing, tap the [Yes] button to start the installation. To import from an external USB flash memory, tap the [No] button. The [Select media to install] window appears as shown in the figure below.

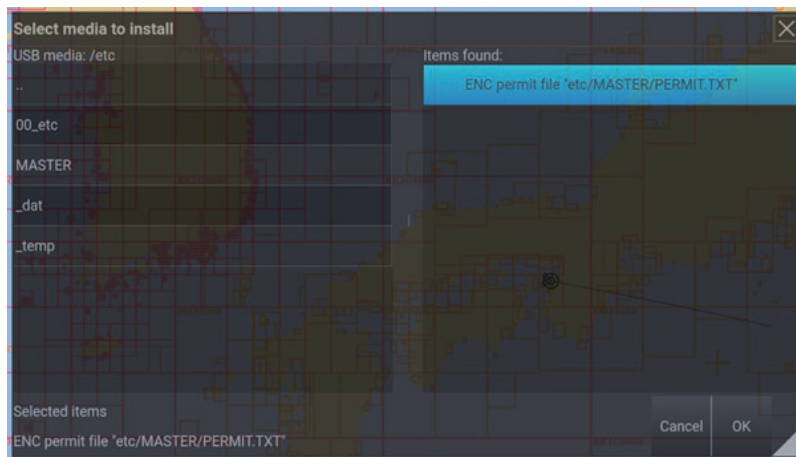
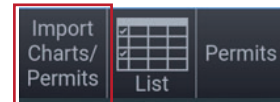
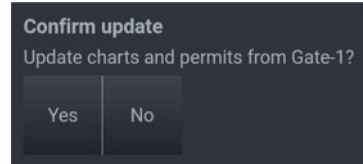

5. Select desired files for importing from the [Items found] window and then tap the [OK] button to start the installation of the selected charts/ENC licenses (permits). To cancel the installation, tap the [Cancel] button.
6. When the installation is completed, the [Finished] window appears, showing the installation results. Tap the [Close] or [X] button to finish.

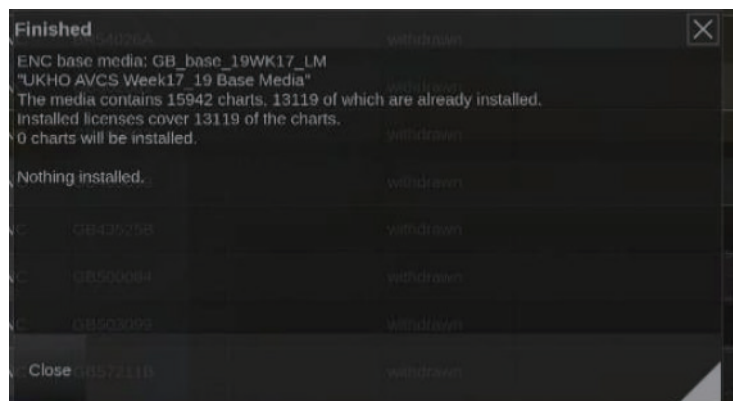

### 3.1.2 How to import public key

1. Tap the [Chart] button and select [Manage Charts] to go to the [Manage Charts] mode.
2. Tap the [Settings] button and select [Import Public Key].

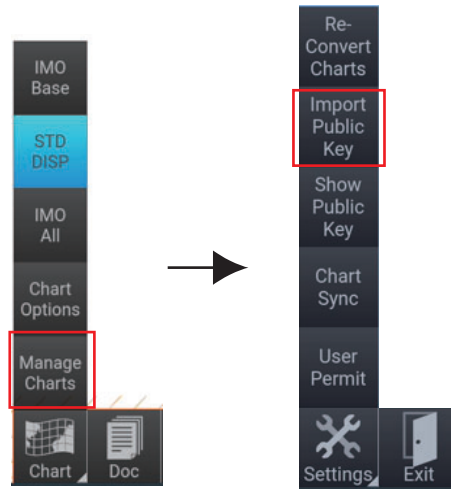

3. The [Select media to install] window appears when using a USB flash memory. Select desired files for importing.
4. Tap the [OK] button to start the installation.

#### How to show the public key

1. Tap the [Chart] button and select [Manage Charts] to go to the [Manage Charts] mode.
2. Tap the [Settings] button and select [Show Public Key]. The window shown below appears and shows the information about the public key.

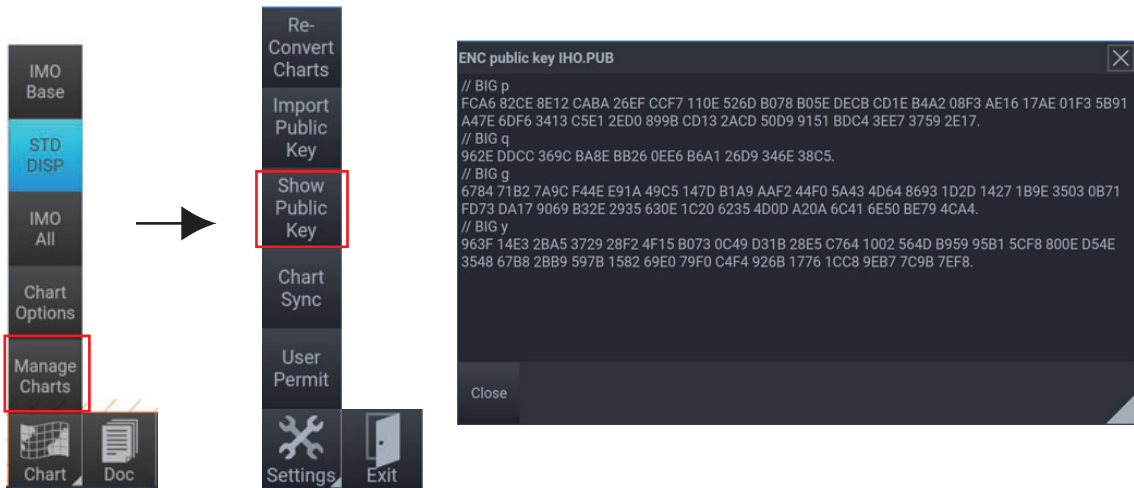

3. Tap the [Close] to close the window.

### 3. HOW TO MANAGE CHARTS

#### 3.1.3 How to check up-to-date status of charts

1. Tap the [Chart] button and select [Manage Charts] to go to the [Manage Charts] mode.
2. Tap [List] to view the [Chart List] window, which shows chart up-to-date status.  
**Note:** Tap and hold (more than 1s) on the chart list to open the context menu shown below. You can select [Go to] or [Open] for the selected chart.

Tap and hold to open the menu on [Chart List].

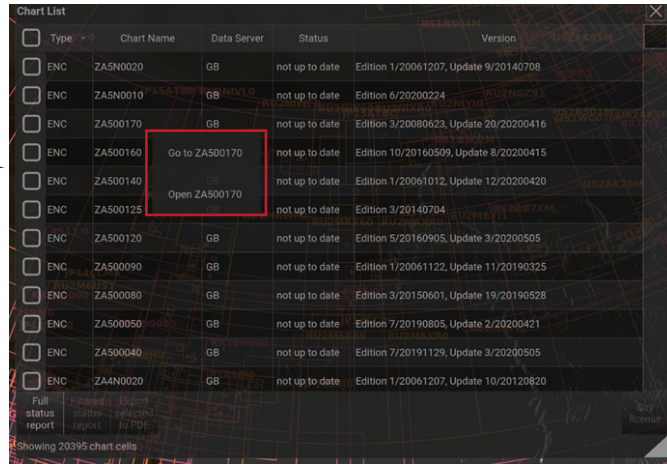

#### 3.1.4 How to view the ENC update log

1. Tap the [Chart] button and select [Manage Charts] to go to the [Manage Charts] mode.
2. Tap [Update log] and then [ENC] to view the ENC update log, which lists all ENC chart updates. A sample ENC update log is shown in the figure below.

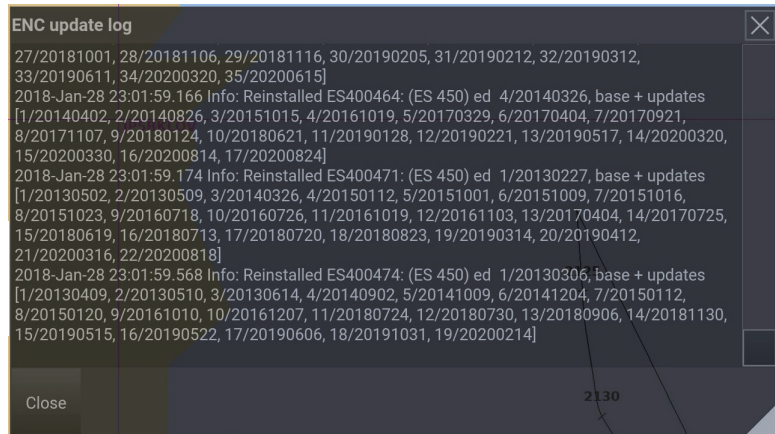
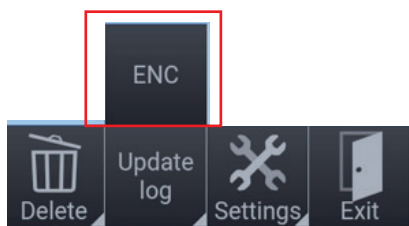

**How to check the list of permits loaded into the system**

1. Tap the [Chart] button and select [Manage Charts] to go to the [Manage Charts] mode.
2. Tap [Permits] to view loaded permits, an example of which is shown in the window below.

<input type="checkbox"/>	Type	Chart Cell	Expiry Date	Data Server	Subscription Type
<input type="checkbox"/>	ENC	1U419233	30 Nov 2020	GB	subscription
<input type="checkbox"/>	ENC	1U419232	30 Nov 2020	GB	subscription
<input type="checkbox"/>	ENC	1U660302	30 Nov 2020	GB	subscription
<input type="checkbox"/>	ENC	1U561001	30 Nov 2020	GB	subscription
<input type="checkbox"/>	ENC	1U560202	30 Nov 2020	GB	subscription
<input type="checkbox"/>	ENC	1U50361A	30 Nov 2020	GB	subscription
<input type="checkbox"/>	ENC	1U50354A	30 Nov 2020	GB	subscription
<input type="checkbox"/>	ENC	1U50353B	30 Nov 2020	GB	subscription

Showing 13225 permits

**3.1.5 How to order chart licenses directly from the Chart Catalog**

If you have the optional Gate-1 service installed for the Planning Station, you can purchase a license (permits) from the Chart Catalog for the charts which are unavailable at the moment and place the order through the Gate-1. For more information about Gate-1, contact your local Furuno dealer.

**Note:** Charts and licenses that are ordered through Gate-1 are recorded with the purchase information shown on the [ENC update log] window (see subsection 3.1.4).

1. Tap the [Chart] button and select [Manage Charts] to go to the [Manage Charts] mode.
2. Select [List] to show the [Chart List] window.
3. Place a check in the checkbox of the chart(s) to purchase, then tap the [Buy License] button.

<input type="checkbox"/>	Type	Chart Name	Data Server	Status	Version
<input checked="" type="checkbox"/>	ENC	1U421242	GB	not up to date	Edition 4/20210824, Update 1/20211024
<input checked="" type="checkbox"/>	ENC	1U421243		not installed	
<input checked="" type="checkbox"/>	ENC	1U421250		not installed	
<input type="checkbox"/>	ENC	1U421251		not installed	
<input type="checkbox"/>	ENC	1U421252	GB	not up to date	Edition 3/20210620, Update 4/20211024
<input type="checkbox"/>	ENC	1U421253	GB	not up to date	Edition 1/20201002
<input type="checkbox"/>	ENC	1U422211		not installed	
<input type="checkbox"/>	ENC	1U422220	GB	not up to date	Edition 2/20210313, Update 1/20211031
<input type="checkbox"/>	ENC	1U422221	GB	not up to date	Edition 2/20210319
<input type="checkbox"/>	ENC	1U422230	GB	not up to date	Edition 2/20210406, Update 1/20211031

Showing 18572 chart cells (7 charts selected)

Full Status Report | Filtered Status Report | Export Selected To PDF | Buy License

### 3. HOW TO MANAGE CHARTS

- The [Prepare chart order] window appears. Select the duration (options: 3 months, 6 months, 9 months or 12 months) and then tap the [Create Order] button.

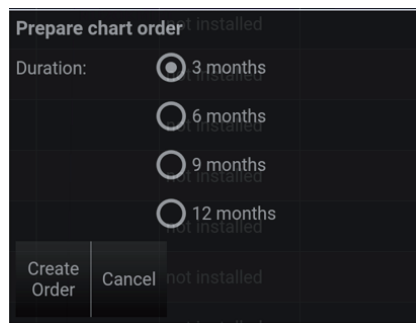

- The [Confirm chart order] window appears. The cost for each chart and the total cost are shown.

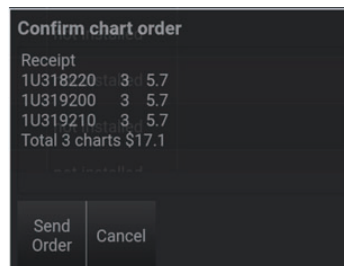

- Tap [Send Order] to confirm the order and finish.

#### 3.1.6 How to reconvert charts

- Tap the [Chart] button and select [Manage Charts] to go to the [Manage Charts] mode.
- Tap the [Settings] button.
- Tap the [Re-convert charts] button. The message "Are you sure?" asks if you are sure to reconvert.
- Tap the button within five (5) seconds. The reconversion starts and the [Chart Reconversion] window appears. The reconversion progress is shown at the bottom of the screen. When reconversion is completed successfully, the [Finished] window appears and the message "Finished reconversion process" appears.
- Tap the [Close] button to finish.





## 3.2 Chart Catalog Legend

The Chart Catalog Legend lets you display charts [By status] or [By purpose]. The coverage areas are shown in a color according to chart status or chart type.

### [By status]

- Green: Chart up-to-date.
- Dark green: Chart up-to-date, renew license.
- Orange: Chart not up-to-date.
- Blue: Chart status unknown.
- Magenta: Chart not installed.
- Yellow: License expired.
- Red: No valid license.
- White: Chart is withdrawn or corrupted.

### [By purpose]

- Magenta: Overview
- Blue: General
- Green: Coastal
- Yellow: Approach
- Orange: Harbour
- Red: Berthing
- White: Other

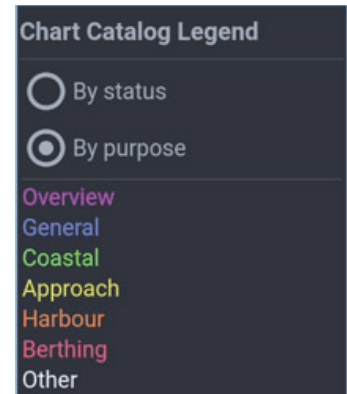
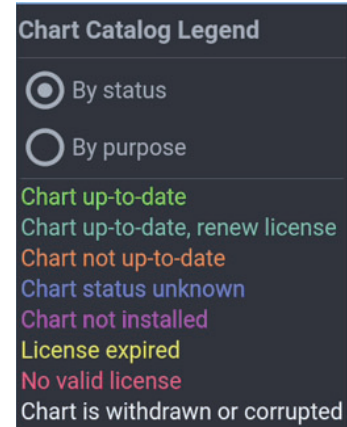

### 3.3 How to Delete Charts/Permits

#### All charts and permits

1. Tap the [Chart] button and select [Manage Charts] to go to the [Manage Charts] mode.

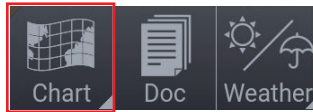

2. Tap the [Delete] button and select [All].

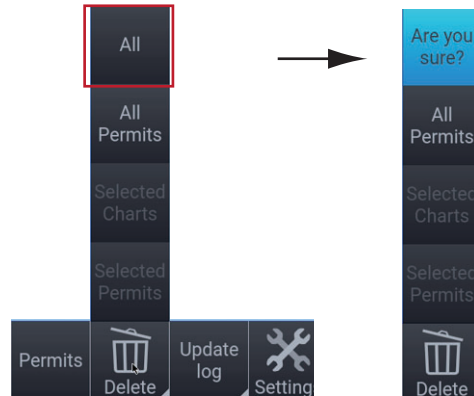

3. The [All] button changes to the [Are you sure?] button. Tap the button within five (5) seconds to delete all charts and permits.
4. The [Finished] window appears. Tap [Close] to finish.

#### Selected charts

1. Tap the [Chart] button and select [Manage Charts] to go to the [Manage Charts] mode.
2. Tap the [List] button to open the [Chart List] window.

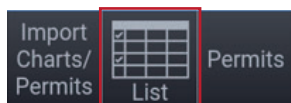

<input type="checkbox"/>	Type	Chart Name	Data Server	Status	Version
<input type="checkbox"/>	ENC	1U421242	GB	not up to date	Edition 4/20210824, Update 1/20211024
<input type="checkbox"/>	ENC	1U421243		not installed	
<input type="checkbox"/>	ENC	1U421250		not installed	
<input type="checkbox"/>	ENC	1U421251		not installed	
<input type="checkbox"/>	ENC	1U421252	GB	not up to date	Edition 3/20210620, Update 4/20211024
<input type="checkbox"/>	ENC	1U421253	GB	not up to date	Edition 1/20201002
<input type="checkbox"/>	ENC	1U422211		not installed	
<input type="checkbox"/>	ENC	1U422220	GB	not up to date	Edition 2/20210313, Update 1/20211031
<input type="checkbox"/>	ENC	1U422221	GB	not up to date	Edition 2/20210319
<input type="checkbox"/>	ENC	1U422230	GB	not up to date	Edition 2/20210406, Update 1/20211031

Full Status Report | Filtered Status Report | Export Selected To PDF | Buy License

Showing 18572 chart cells

3. Select the chart(s) to delete. Also all charts can be selected by checking the box on the title line.

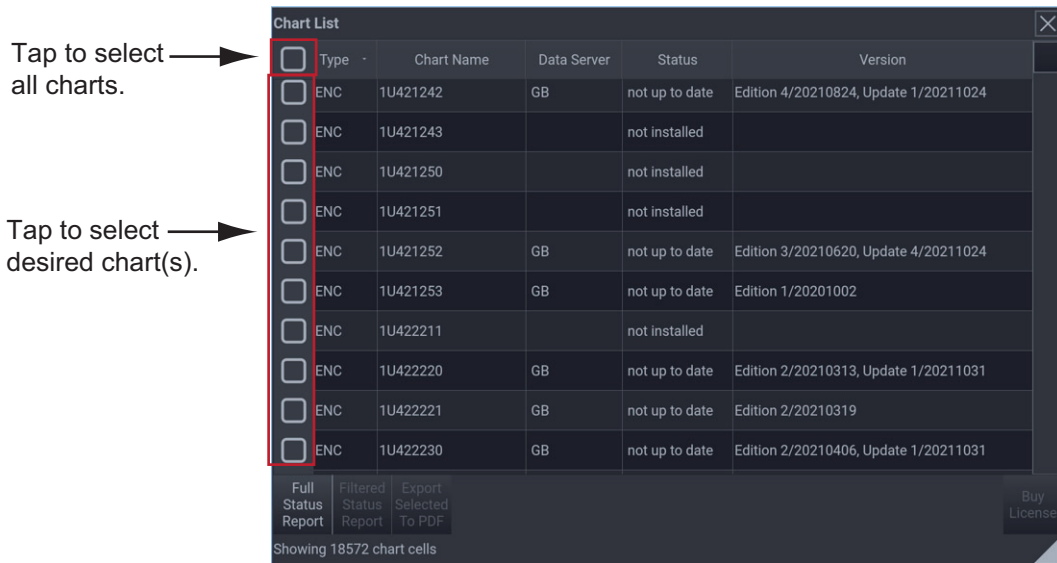

4. Tap the [Delete] and [Selected Charts] buttons to delete selected charts.

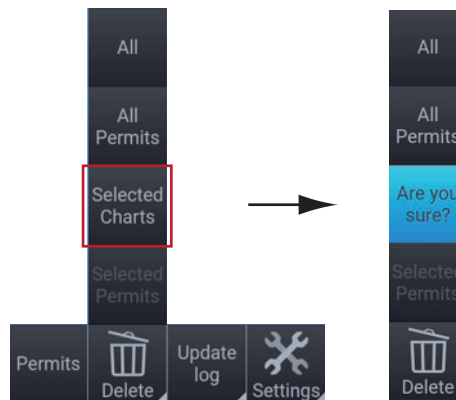

5. The [Selected Charts] button changes to the [Are you sure?] button. Tap the button within five (5) seconds to delete.
6. The [Finished] window appears. Tap [Close] to finish.

**All permits**

1. Tap the [Chart] button and select [Manage Charts] to go to the [Manage Charts] mode.
2. Tap the [Delete] button and select [All Permits].

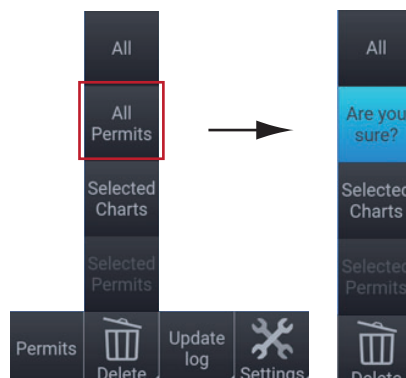

### 3. HOW TO MANAGE CHARTS

3. The [All Permits] button changes to the [Are you sure?] button. Tap the button within five (5) seconds to delete all permits.
4. The [Finished] window appears. Tap [Close] to finish.

#### **Selected permits**

1. Tap the [Chart] button and select [Manage Charts] to go to the [Manage Charts] mode.
2. Tap [Permits] button to open [Permit List] window.

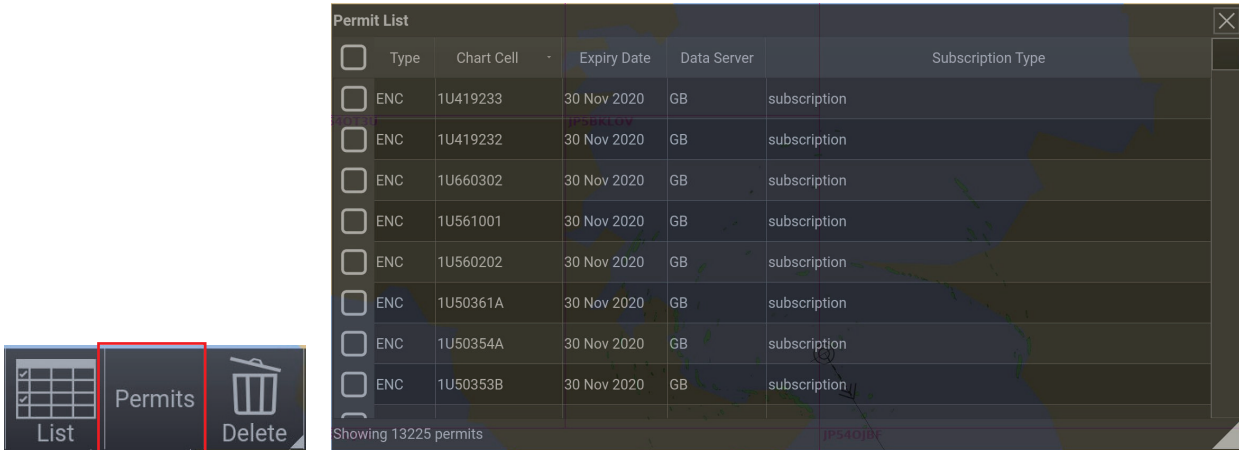

3. Select the permits to delete. Also all permits can be selected by checking the check box on the title line.

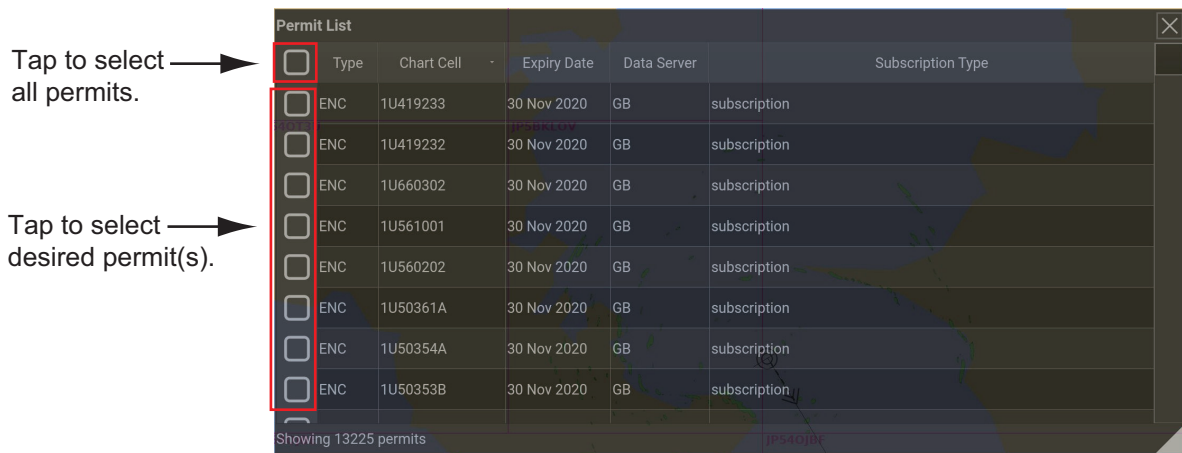

4. Tap the [Delete] and [Selected Permits] buttons to delete selected permits.
5. The [Selected Permits] button changes to the [Are you sure?] button. Tap the button within five (5) seconds to delete selected permits.
6. The [Finished] window appears. Tap [Close] to finish.

## 3.4 How to Use filter of the Chart Catalog

You can use the Chart Catalog filters to select the charts to display on the Planning Station. Tap the [Chart] button and select [Manage Charts] to open the Chart Catalog display. The [Chart Catalog Filter] window will be automatically displayed. You can limit the number of charts to display by categories. When unchecked, no filters are used. The categories for filtering are as follows:

- [Availability]: Filter by chart display status (options: available or unavailable).
- [License]: Filter by chart license status (Options: [Valid], [Expires within] or [Expired/no license]. When [Expires within] is selected, you can specify the licenses by entering the license expiration date (setting range: 0 to 365 days)
- [Status]: Filter by chart updating status (options: Up-to-date, Not up-to-date, Unknown, Corrupted, Withdrawn). See also section 3.2.
- [Route]: Filter by chart used by selected route. See subsection 3.4.1 for details.

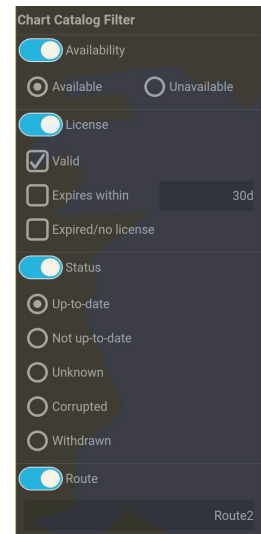

### 3.4.1 How to view a list of charts for a route

The Chart Catalog filter can show you a list of the charts needed to monitor a route.

1. Tap the [Chart] button and select [Manage charts] to go to the [Manage Charts] mode.
2. Tap [Route] to show ON in the [Chart Catalog Filter] window and then tap the field below to display the [Choose Route] window, which shows a list of the saved routes.

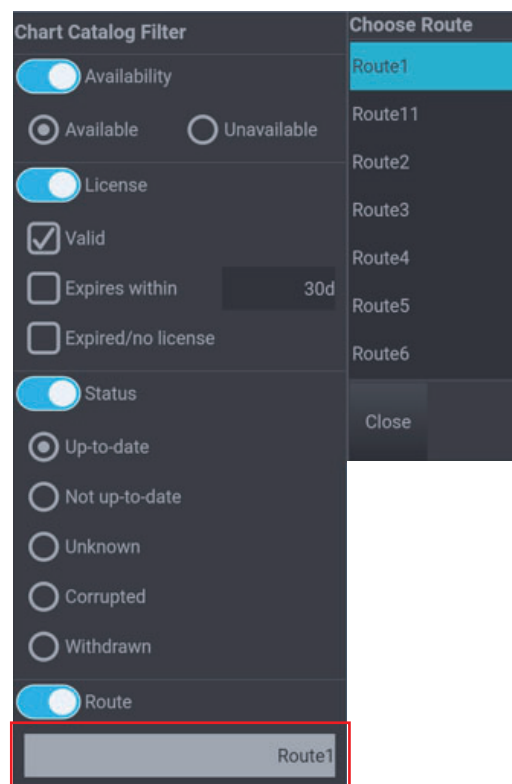

### 3. HOW TO MANAGE CHARTS

3. Select the desired route. If you select any other filter, they also affect the list of charts. You can view, for example, charts which are not up-to-date or charts which are unavailable.
4. Tap the [List] button to open the [Chart List] window.

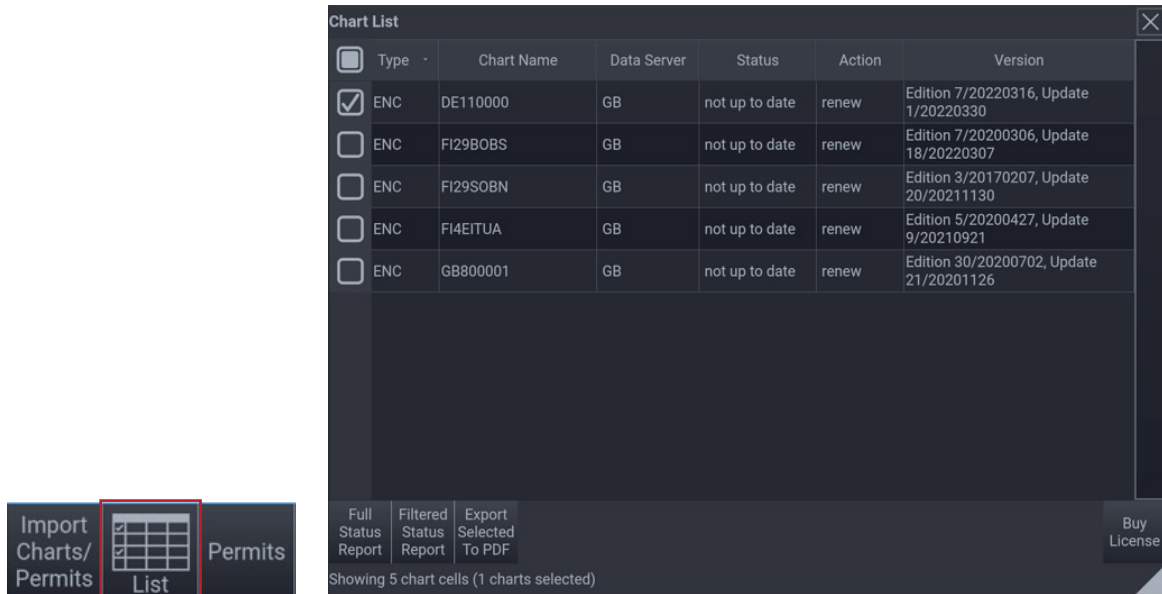

5. Check the desired chart on the check box. When a chart is selected, the [Export Selected to PDF] button becomes available.
6. Tap the [Export Selected to PDF] button.
7. Assign a name on the [Export chart list] window and then tap the [OK] button. The [Chart list exported] confirmation window appears.
8. Tap the [Open PDF] button to see the PDF file or tap the [Close] button to finish. The PDF is saved to the [Imported Documents] list for exporting to a USB flash memory. (See subsection 12.2.)

**Note:** You can also select the [Filtered Status Report] or [the Full Status Report] to export the chart list to PDF. The exported PDF is saved to the [Imported documents] list.

## 3.5 How to Select Displayed Chart Objects of ENC

Chart objects can be shown or hidden on the chart using the [Chart Options] menu. The [DEPTH] window sets depth values which are suitable for your vessel and for your intended voyage. Additionally, you can set predefined IMO chart displays; IMO Base, standard display, or IMO ALL.

**Note:** See also section 3.6 “Chart Display Settings” for further information.

Tap the [Chart] button and then select [Chart Options]. Chart objects can be shown or hidden with the windows shown in the figure below.

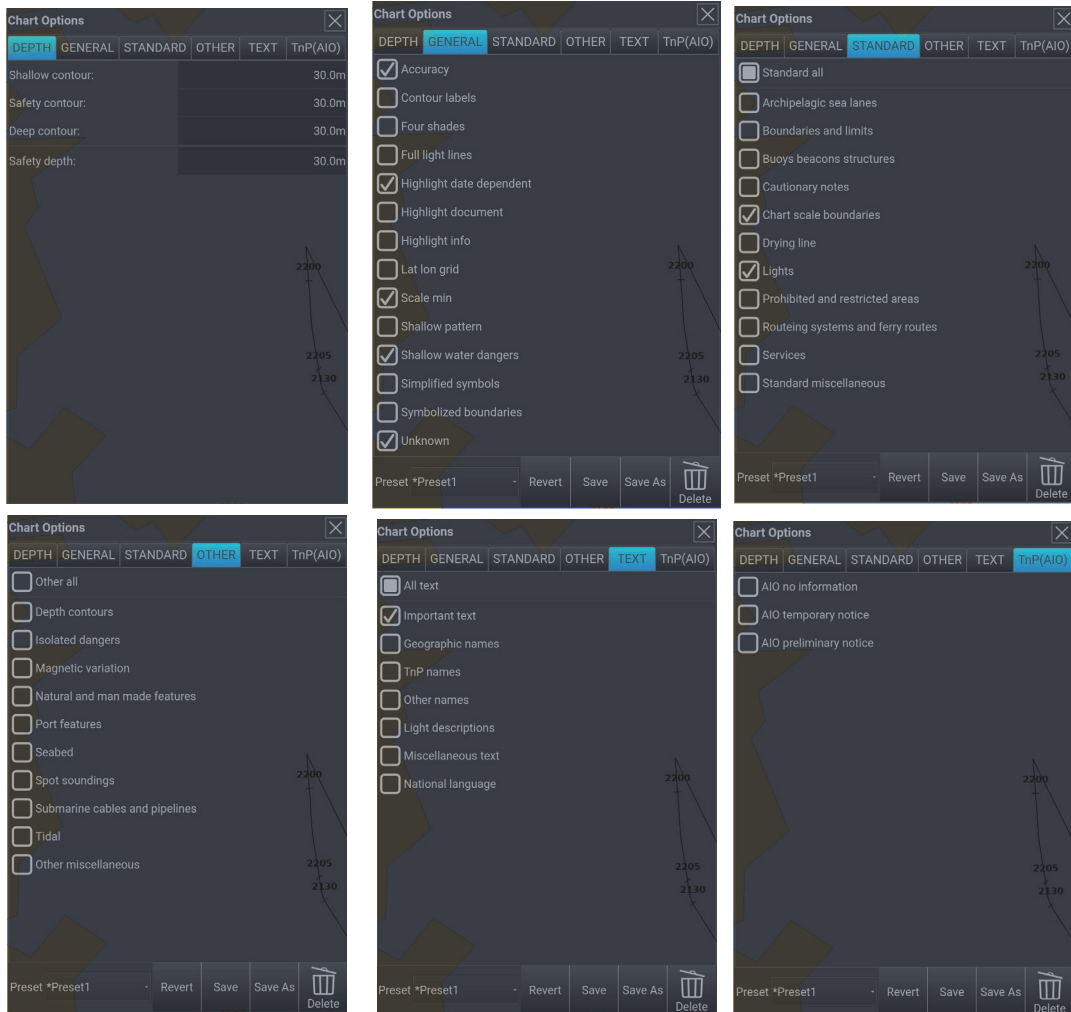

- [DEPTH]: Shallow contour, Safety contour, Deep contour, Safety depth settings
- [GENERAL]: General chart object display settings, ON/OFF
- [STANDARD]: Standardized IMO object display settings, ON/OFF
- [OTHER]: Other than IMO object display settings, ON/OFF
- [TEXT]: Text information display settings, ON/OFF
- [TnP (AIO)]: Temporary and Preliminary Notices (T&P) display settings, ON/OFF

### 3. HOW TO MANAGE CHARTS

#### 3.5.1 How to save presets for later use

You can predefine chart object sets and save them for later use. This is useful to display certain chart objects according to navigation purpose. Check desired objects and then tap the [Save As] button and give a name for the preset. A maximum of nine (9) presets can be saved in addition to default.

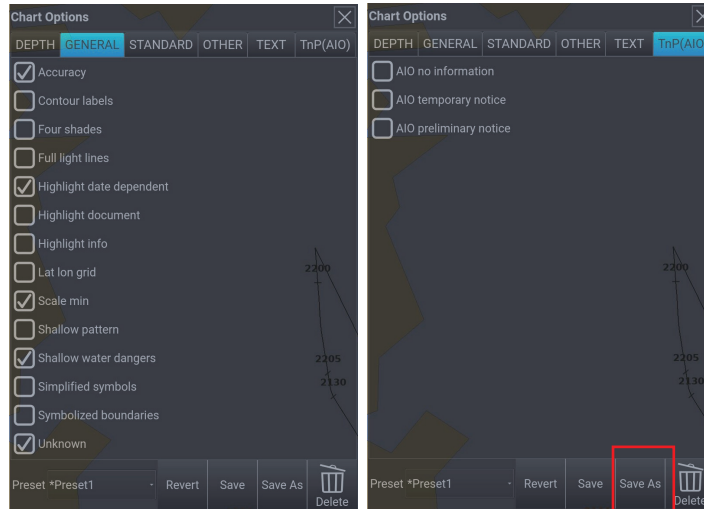

Whenever you modify your settings, an asterisk (\*) appears in front of the name. Tap the [Save] button to save changes. The [Save] button changes to the [Are you sure?] button. Tap the button within five (5) seconds to save. If you don't want to save the changes, tap the [Revert] button.

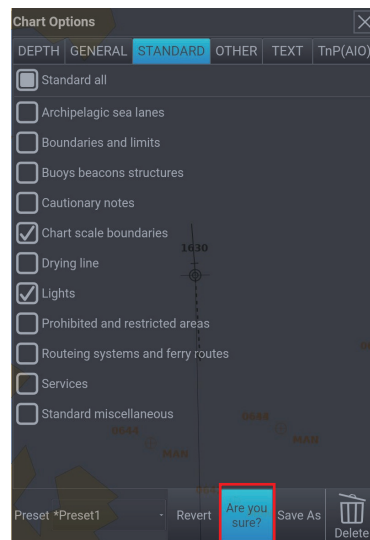

Tap within five seconds



## 3.6 Chart Display Settings

There are three sets of predefined chart display settings that can be used to display charts with certain chart features. Tap the [Chart] button at the bottom of the display and select one of the following options. The currently selected setting is highlighted in blue as shown in the figure at right.

- [IMO Base]: Uncheck all options of [STANDARD] and [OTHER] tab on [Chart options] window.
- [STD DISP] (Standard Display): Check all options of [STANDARD] tab and uncheck all options of [OTHER] tab on [Chart options] window.
- [IMO All]: Check all options of [STANDARD] and [OTHER] tab on [Chart options] window.

**Note:** See also section 3.5 for further information about the [Chart options] window.

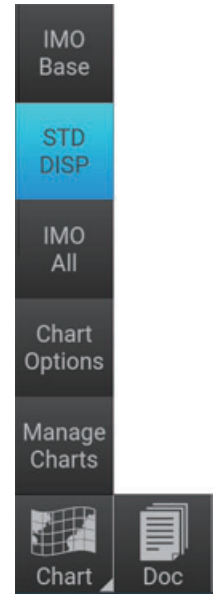

### 3. HOW TO MANAGE CHARTS

This page is intentionally left blank.

# 4. OWN SHIP

---

## 4.1 Past Track of Own Ship

You can show the past tracks of own ship on the display. You can set the length of the track and the interval of time stamps.

1. Tap the [Own Ship] button and select [Settings] to show the [Own Ship Settings] window.

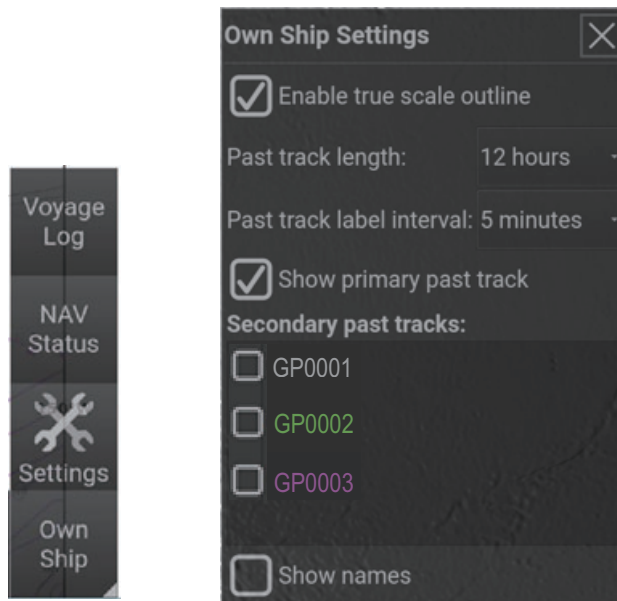

2. Set the past track length (Options: Off, 1 hours, 2 hours, 5 hours, 12 hours, 24 hours).
3. Set the past track label interval (time stamp) for past track (Options: Off, 1 minutes, 5 minutes, 10 minutes, 30 minutes, 60 minutes).
4. Select whether to show the primary past track (displays own ship's track).
5. Select whether to show the secondary past tracks. The Secondary past track is used to search connected normally operating sensors sources when an error occurs with the monitored sensor source. The priority of the sensors to be displayed can be adjusted in the [Sensor Source] window (see subsection 2.4.1).  
**Note:** Not shown when past track length is set to [Off].
6. Select [Show names] to display the sensor source names.

## 4.2 Voyage Log

The Voyage log records position, speed, heading, course and other navigation information. For each entry a textual description can be inserted. The voyage log records all voyage-related data of the past three months, and can be viewed in the [Chart usage] log.

### 4.2.1 How to view the Voyage Log

Do the following to display the [Voyage Log].

1. Tap the [Own Ship] button and select [Voyage Log] to show the [Voyage Log] window.

Time (UTC)	POSN	HDG	COG	SOG	Descripti
16:32:45 28 Jan 2018	35°15.826 N 139°46.085 E	145.3°	140.9°	12.6 kn	
16:31:45 28 Jan 2018	35°15.988 N 139°45.924 E	145.8°	141.0°	12.5 kn	
16:30:45 28 Jan 2018	35°16.152 N 139°45.765 E	145.7°	140.4°	12.5 kn	
16:29:45 28 Jan 2018	35°16.313 N 139°45.605 E	145.5°	141.1°	12.5 kn	
16:28:45 28 Jan 2018	35°16.478 N 139°45.448 E	146.1°	142.0°	12.7 kn	
16:27:45 28 Jan 2018	35°16.645 N 139°45.287 E	145.0°	143.7°	12.8 kn	
16:26:45 28 Jan 2018	35°16.820 N 139°45.138 E	148.4°	147.4°	13.0 kn	
16:25:45 28 Jan 2018	35°17.003 N 139°44.994 E	148.6°	146.7°	13.1 kn	
16:24:45 28 Jan 2018	35°17.183 N 139°44.846 E	148.1°	145.6°	13.1 kn	
16:23:45 28 Jan 2018	35°17.361 N 139°44.693 E	147.1°	144.6°	13.1 kn	
16:22:45 28 Jan 2018	35°17.537 N 139°44.537 E	147.0°	144.8°	13.1 kn	
16:21:45 28 Jan 2018	35°17.716 N 139°44.384 E	147.0°	144.9°	13.1 kn	

2. Tap desired row to show the position on the chart.
3. Tap the [Description] cell to show the software keyboard and add description to voyage log.
4. Tap the [Show Details] button to show type and sensor source information details.

## 4.2.2 How to select period of time in the Voyage Log

You can set time period for stored data shown on the [Voyage Log]. This is useful when you want to export data to external data storage or playback movement of own ship.

1. Tap the [Own Ship] button and select [Voyage Log].
2. In the [Period] field, select the first time period to view the Voyage Log ([Until present moment], [Until], [From]).

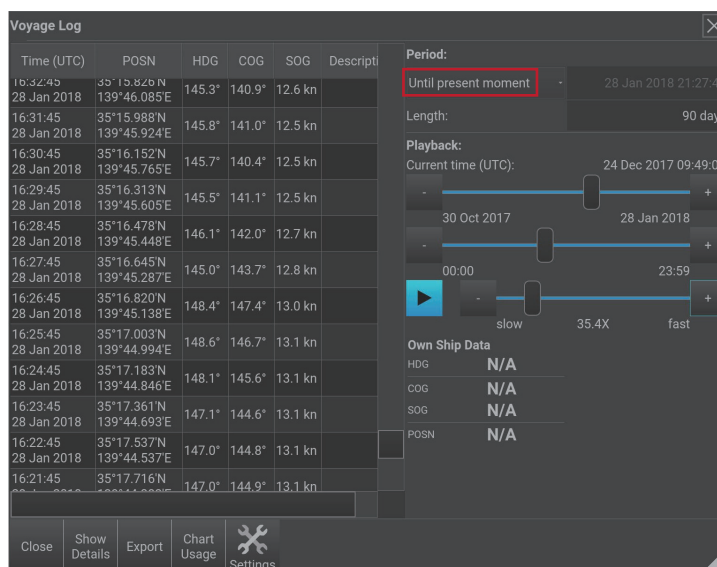

← Select first time period to view.

## 4.2.3 How to export data from the Voyage Log

1. Tap the [Own Ship] button and select [Voyage Log].
2. In the [Period] field, select the period to view the Voyage Log (options: [Until present moment], [Until], [From]).
3. Connect a USB flash memory to the USB port.
4. Tap the [Export] button. The catalog is exported in the following format.
  - File extension: csv (comma-separated value)
  - Encoding format: UTF-8

## 4. OWN SHIP

### 4.2.4 How to use the playback mode

The Playback mode is used to view the movement of own ship in the selected time period, selected from the Voyage log.

When the Playback mode is activated, you can view the history of own ship track with the own ship symbol. Own ship data displays the sensor data recorded during the period. If a route was monitored during that period, it is displayed below the sensor data.

Sensor information and own ship symbol are based on current information.

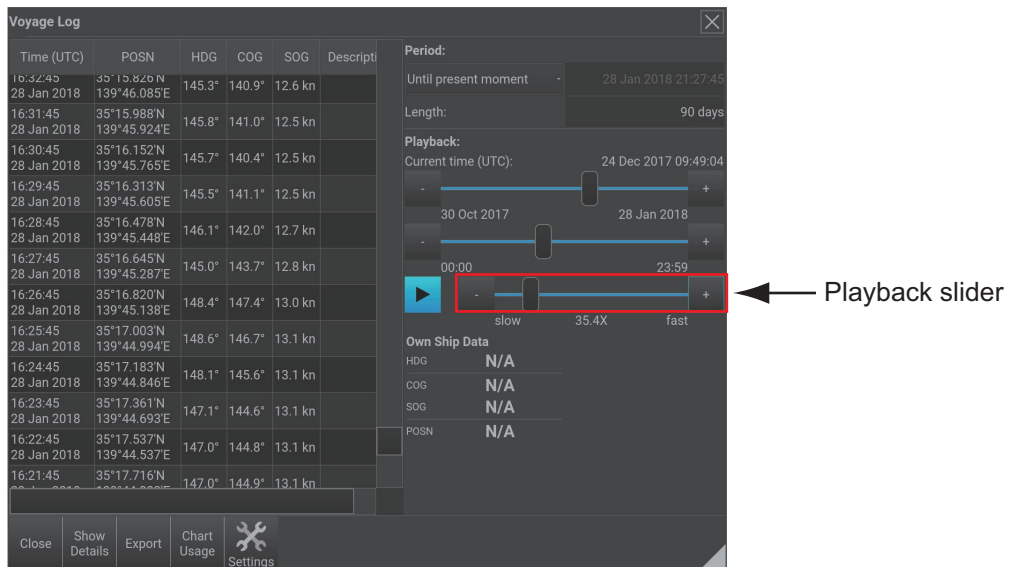

To use the playback mode, do the following procedure.

1. In the [Period] field, select the initial period to view [Voyage Log] (options: [Until present moment], [Until], [From]).
2. Use the sliders in the [Playback] field to set date and time for playback, which is shown above sliders.
3. Start the play back by tapping the [Play] button. The button is highlighted when active. Use the slider next to the [Play] button to set the speed of the playback.
4. To stop playback, tap the [Play] button again.

### How change color of track and own ship symbol in playback

In the [Voyage Log] window, tap the [Settings] button to show the [Voyage Log Settings] window. Select desired color for played back track and own ship symbol (options: Green, Blue, Black/White, Magenta, Brown).

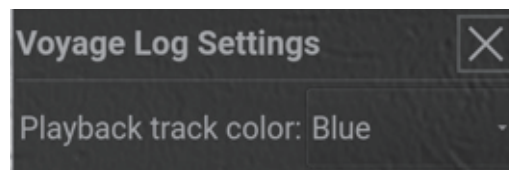

#### 4.2.5 Chart usage log

1. Tap the [Own Ship] button and select [Voyage Log].
2. Tap the [Chart Usage] button to open the [Voyage Log].

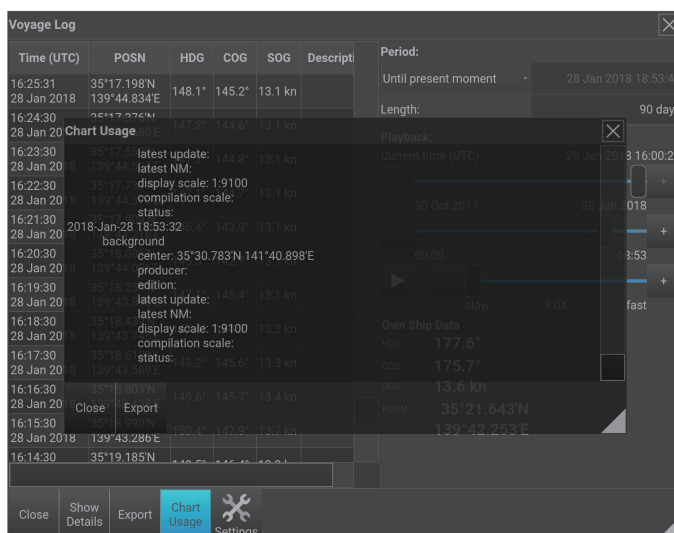

3. To export the [Chart Usage] log, connect a USB flash memory to the USB port and tap the [Export] button. The [Select target directory] window appears.
4. Select the applicable directory from the list and tap the [OK] button to export the Chart Usage log.
5. The [Finished] window appears. Tap the [Close] button to close the window and finish.

## 4.3 How to View Navigation Status of Own Ship

You can view navigation status of own ship. Tap the [Own Ship] button and then tap the [NAV Status] button to open the [Navigation Status] window. You can view navigation status information of own ship, which is transmitted by an AIS transponder.

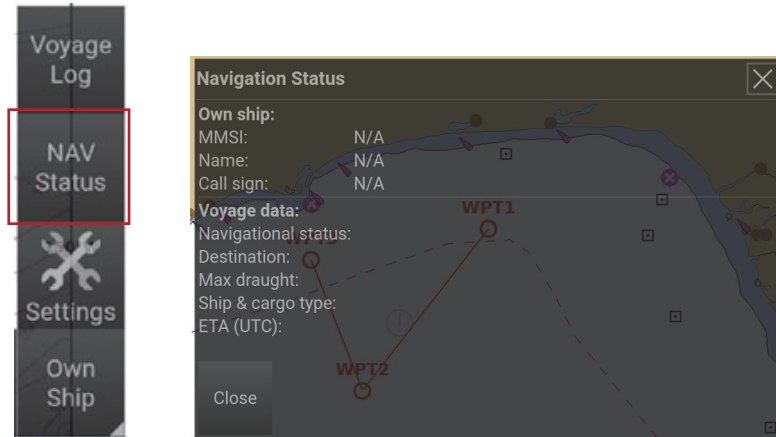

## 4.4 Vector

### 4.4.1 How to set the vector length

1. Tap the [Vector] button to display the [Speed vector] window, which is shown in the figure below.
2. Set the desired vector length (Options: 60min, 30min, 15min, 12min, 10min, 6min, 5min, 3min, 2min, 1min, or OFF). The set speed is displayed on the [Vector] button as shown below. Check the "Relative (R)" check box to use relative vector reference.

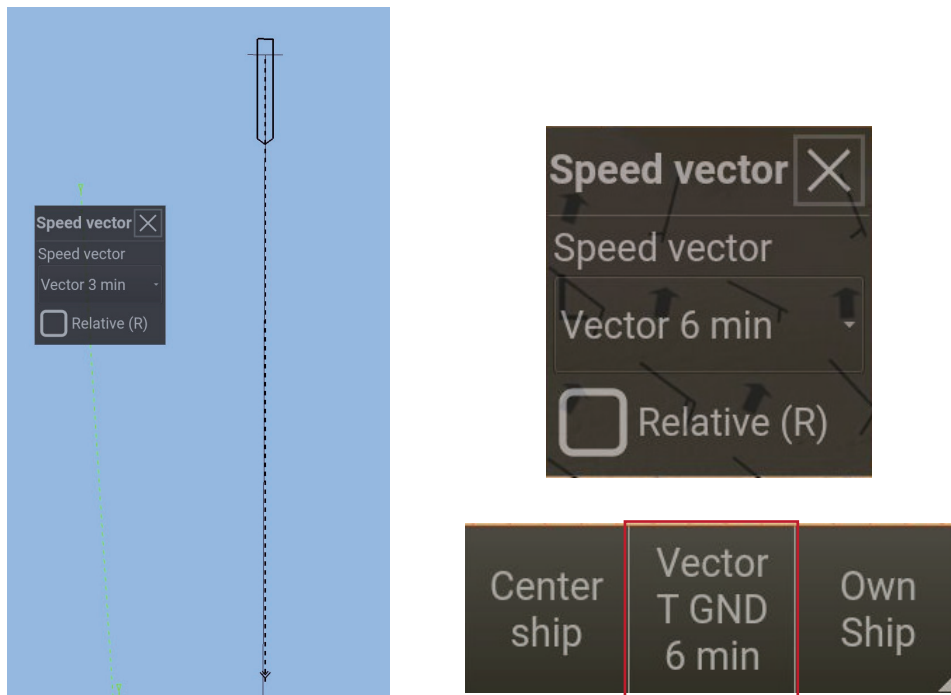



# 5. ROUTES

## 5.1 Route Functions

The Planning Station provides basic route functions such as route planning and route monitoring. When the ECDIS FMD-3xxx is connected in the same Local Area Network (LAN), routes are automatically synchronized between the ECDIS and the Planning Station. The Planning Station provides the following route functions; route creation, route editing, and viewing multiple routes.

**Note:** To synchronize route data, it may be necessary to update the software for the FMD-3xxx. Contact point of purchase or a FURUNO dealer for the appropriate software version for the Planning Station.

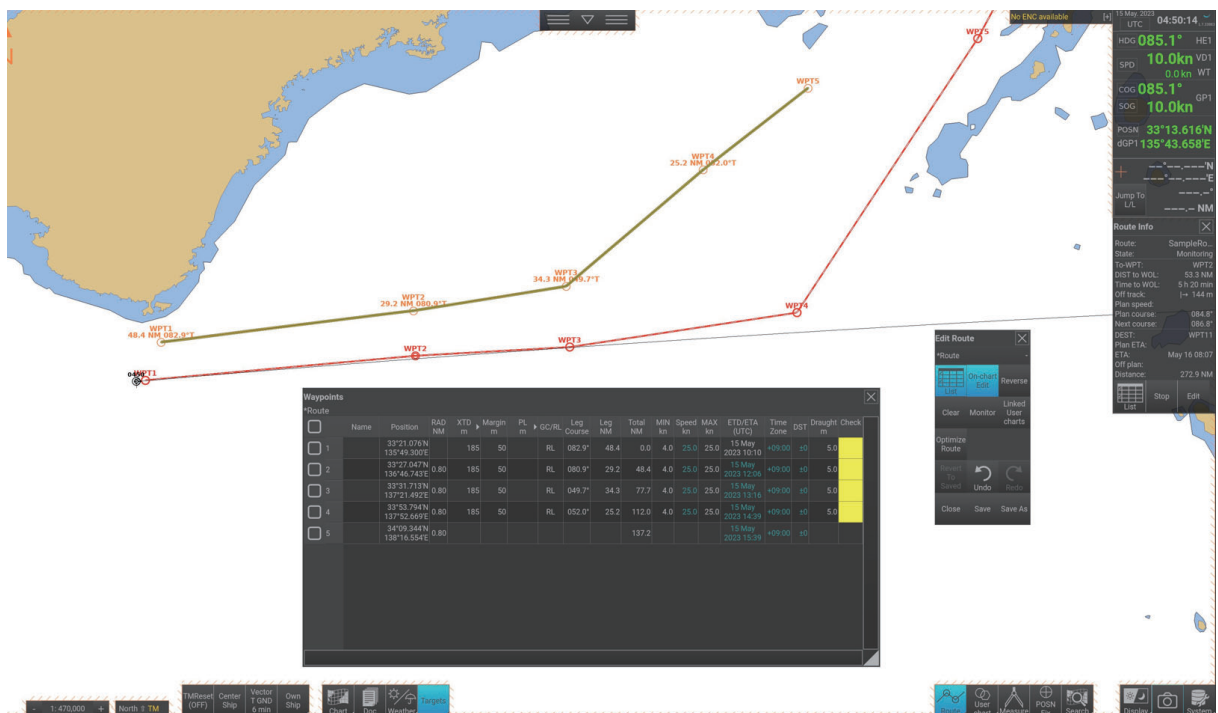

- [Bad turn]: A turn cannot be made for a waypoint. Reduce the turning radius of the waypoint.
- [Bad leg]: The leg is too short. Adjust the latitude/longitude values of the waypoint.
- [Impossible turn]: A turn cannot be made at a waypoint. Reduce the turning radius of the waypoint and adjust the latitude/longitude values of the waypoint.
- [Impossible leg]: The leg is not available because the destination is located at a high latitude value and cannot be calculated (the error rate is too high). Change the waypoint GC/RL to GC and adjust the latitude/longitude values of the waypoint.



## 5. ROUTES

Icons and route display colors vary depending on the status in [Select Route] window.

### Icons

- Not displayed: A route is being selected.
- : Route is being edited.
- : Route is being edited/monitored on the ECDIS/RADAR side.
- : Conflict with the ECDIS/RADAR data.

### Display colors

- White: Route is being selected.
- Blue: Route is being edited.
- Green: Route is being monitored on the ECDIS/RADAR side.
- Yellow: Conflict with ECDIS/RADAR data.

## 5.2 How to Create a Route

Do the following to create a route.

1. Tap the [Route] button.
2. Tap the [New] button on the menu to show the [Edit Route] window.

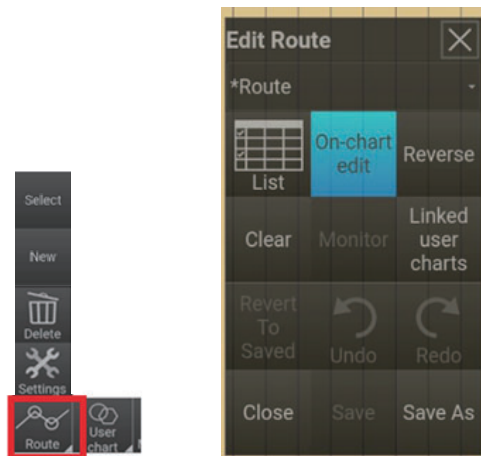

3. Set the position for a waypoint (WPT) by tapping desired WPT location on the chart. Open the waypoint list by tapping the [List] button on the [Edit Route] window.
4. Tap to add waypoints or drag to desired location on chart.

5. Waypoint items can be edited in the [Waypoints] list. Tap the setting to change.

	①	②	③	④	⑤	⑥	⑦	⑧	⑨	⑩	⑪	⑫	⑬	⑭	⑮	⑯	⑰	⑱
	Name	Position	RAD NM	XTD m	Margin m	PL m	GC/RL	Leg course	Leg NM	Total NM	MIN kn	Speed kn	MAX kn	ETD/ETA (local)	Time zone	DST	Draught m	Check
<input type="checkbox"/>	1	25°56.942'N 064°02.971'W		185	50		RL	068.8°	928.9	0.0	4.0		25.0		-04:00		5.0	<input checked="" type="checkbox"/>
<input type="checkbox"/>	2	31°34.416'N 047°34.271'W	0.80	185	50		RL	285.3°	1642.1	928.9	4.0		25.0		-03:00		5.0	<input checked="" type="checkbox"/>
<input type="checkbox"/>	3	38°49.923'N 079°50.509'W	0.80	185	50		RL	006.3°	318.8	2571.0	4.0		25.0		-05:00		5.0	<input checked="" type="checkbox"/>
<input type="checkbox"/>	4	44°06.477'N 079°03.983'W	0.80							2889.8					-05:00			<input type="checkbox"/>

The following items can be edited.

No.	Name	Explanation
1	[Name]	Name can be given for each waypoint.
2	[Position]	Position can be entered manually. Tap and hold to open the context menu to do the following operations for the selected position. <ul style="list-style-type: none"> <li>• [Edit WPT position]</li> <li>• [Insert before WPT]</li> <li>• [Insert after WPT]</li> <li>• [Delete selected WPTs]</li> <li>• [Delete WPT]</li> <li>• [Center chart to]</li> <li>• [Copy selected WPTs]</li> </ul>
3	[RAD NM]	Set turning radius at WPT in nautical miles (NM).
4	[XTD m]	Cross track distance in meters (m) for each leg (channel width). Tap the [XTD m] cell to enter XTD value for each side of leg (port, starboard). To hide the [XTD STBD] column, tap the [XTD STBD] cell. Note that you can adjust XTDs directly on the chart. Tap a line to highlight it then you can drag it to desired distance from the center line.
5	[Margin m]	For route check function. Route is checked in channel width and additionally in margin width.
6	[PL m]	Two (2) parallel lines can be entered for each leg. Tap the [PL] cell to show [PL 2] column. To hide [PL 2], tap the [PL 2] cell. Note that you can adjust PL directly on the chart. Tap a line to highlight it and then drag the PL to desired distance from the center line.
7	[GC/RL]	Set leg navigation method, Great Circle or Rhumb Line.
8	[Leg course]	Course between waypoints.

## 5. ROUTES

No.	Name	Explanation
9	[Leg NM]	Distance for a leg.
10	[Total NM]	Total distance.
11	[MIN kn]	Minimum speed for a leg.
12	[Speed kn]	Suggested speed in a leg.
13	[MAX kn]	Maximum speed for a leg.
14	[ETD/ETA (UTC)/ local]	Set departure/arrival time for a leg. Tap [ETD/ETA] to switch between [UTC] and [local] (see also subsection 5.2.1).
15	[Time zone]	Time zone can be set for each leg individually.
16	[DST]	Daylight Saving Time (Default: [Automatic]).
17	[Draught m]	Draught of vessel for a leg.
18	[Check]	Route Check Results (see subsection 5.3.4).

After changing any item(s), save the created route referring to subsection 5.3.5.

## 5.2.1 How to get suggested speed for a route

The suggested speed is shown in the [Speed kn] field in the [Waypoints] list. ETD/ETA must be set at least for one waypoint.

**Note:** If the [Reverse] button is tapped after ETD/ETA is set, all set ETD/ETA will be reset (the field is left blank).

- When ETD is set for the first waypoint, ETA is calculated based on entered MAX speed value.
- When ETA is set for desired waypoint, the speed is calculated based on MAX speed value to arrive by the user-entered time.
- When ETA is not set for the last waypoint, the rest of the route is calculated with MAX speed.

**Max speed:** This calculation uses the maximum speed defined in the ship parameters and multiplies together with speed limits given for each waypoint to generate ETA. ETA may be entered, however it is calculated with user-entered ETD and speed limit.

Set the suggested speed.      Set ETD/ETA.

Waypoints																		
*Route																		
<input type="checkbox"/>	Name	Position	RAD NM	XTD m	Margin m	PL m	GC/RL	Leg Course	Leg NM	Total NM	MIN kn	Speed kn	MAX kn	ETD/ETA (UTC)	Time Zone	DST	Draught m	Check
<input type="checkbox"/>	1	01°38.066'S 012°41.255'W		185	50		RL	308.9°	525.8	0.0	4.0	25.0	25.0	09 May 2023 02:29	-01:00	±0	5.0	Yellow
<input type="checkbox"/>	2	03°53.881'N 019°30.243'W	0.80	185	50		RL	264.4°	686.3	525.8	4.0	25.0	25.0	09 May 2023 23:31	-01:00	±0	5.0	Yellow
<input type="checkbox"/>	3	02°46.854'N 030°53.358'W	0.80	185	50		RL	207.9°	561.7	1212.1	4.0	25.0	25.0	11 May 2023 02:58	-02:00	±0	5.0	Red
<input type="checkbox"/>	4	05°31.524'S 035°16.049'W	0.80							1773.7				12 May 2023 01:26	-03:00	±0		

The text color displayed in the ETD/ETA(local) cell varies depending on the ETD/ETA status.

- White: User-entered ETD/ETA.
- Blue: ETD/ETA is automatically calculated based on the set ETD/ETA value or speed kn.
- Yellow: Based on the automatic calculation, the user-entered ETD/ETA value needs to be adjusted due to occurred changes of the set ETD/ETA.

## 5.3 Route Management

### 5.3.1 How to link a user chart with a route

User chart(s) can be linked with a route. See chapter 6 for information about user charts.

**Note 1:** The user chart and the route can be linked also by other methods than the following procedure. See subsection 6.2.4 for details.

**Note 2:** Up to five (5) user charts can be linked with a route. When the maximum number of links (5) is reached, the icon will be grayed out.

1. Create a new route and open the [Edit Route] window, or tap a saved route in the [Select Route] window and then tap the [Edit ] button to show the [Edit Route] window.
2. Tap the [Linked user charts] button.
3. Select one or more user charts to be linked to the route.
4. Tap the [+] button to link a user chart. Below [Currently linked] field appears a list of the user charts selected.
5. To remove a user chart from the [Currently linked] list, tap the [-] button.

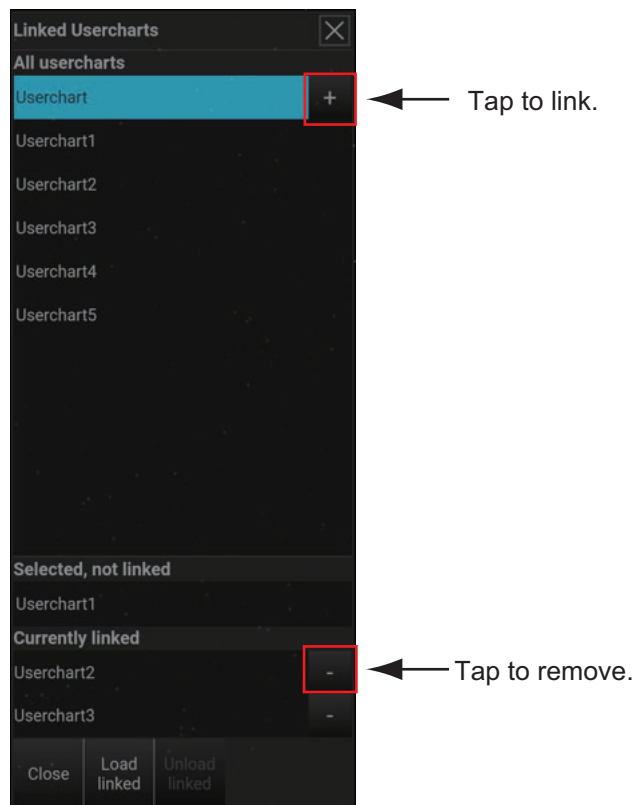

### 5.3.2 How to import routes from a USB flash memory

Route data created on another device (FMD-3xxx, etc.) can be imported to the Planning Station. Save the route data to a USB flash memory, then import it to the Planning Station as follows.

**Note:** Compatible formats: rtz, rtzp.

1. Insert a USB flash memory to the USB port.
2. Tap the [Route] button and tap the [Select] to open the [Select Route] window.
3. Tap the [Import] button to show the [Select files] window.

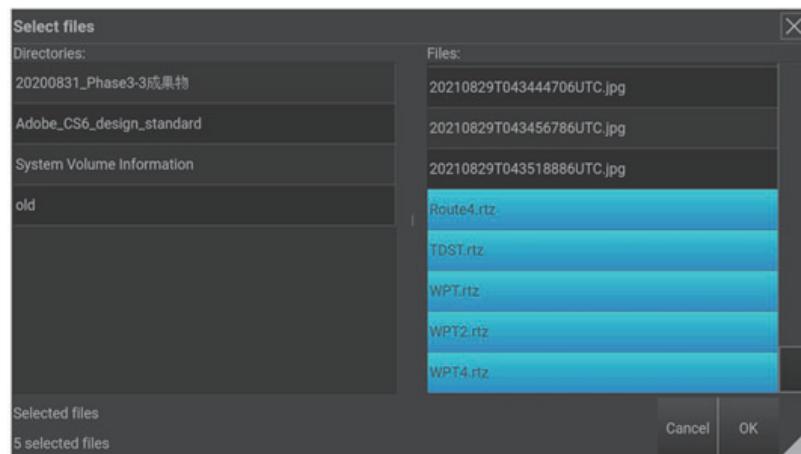

4. Select the file from the [Files] list displayed at the right side of the window and tap the [OK] button. After the importing is completed, the [Finished] window appears, showing import information.

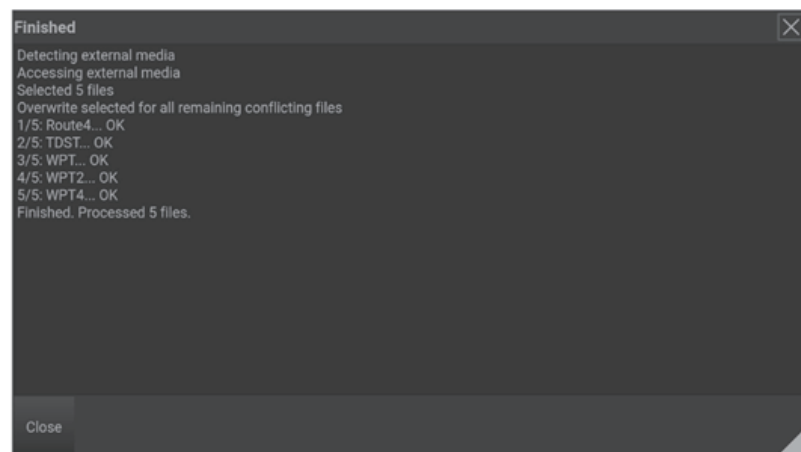

5. Tap the [Close] button to close the window.

### 5.3.3 How to export routes to a USB flash memory

**Note:** The name of route files for export may contain alphanumeric characters. If any of the following alphanumeric characters are used for the file name, they will be replaced with other characters to avoid system impact. However the characters are displayed correctly once more imported. The following symbols are allowed for the file name: \*, /, :, <, >, ?, [, ], \, ", '.

1. Insert a USB flash memory to the USB port.
2. Tap the [Route] button and tap [Select] to open the [Select Route] window.
3. Tap the [Export] button to show the [Select files] window.

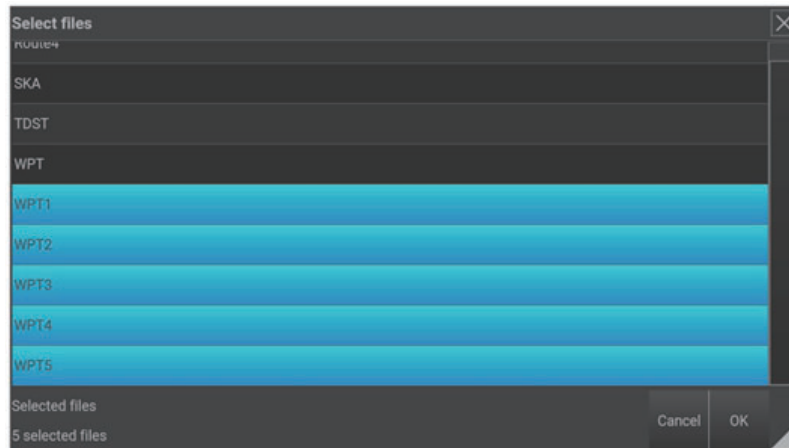

4. Select the file from the [Files] list and tap the [OK] button.
5. The [Select target directory] window appears. After the USB folder is selected, tap the [OK] button.

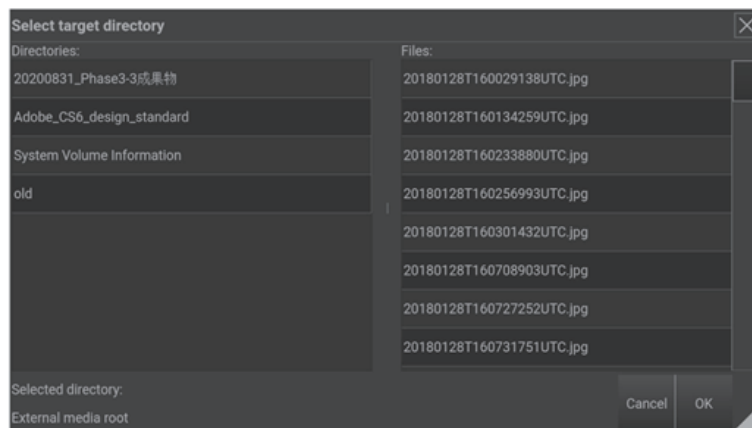



6. After the file(s) are exported, the [Finished] window appears, showing information about the files exported. Tap the [Close] button to close the menu.

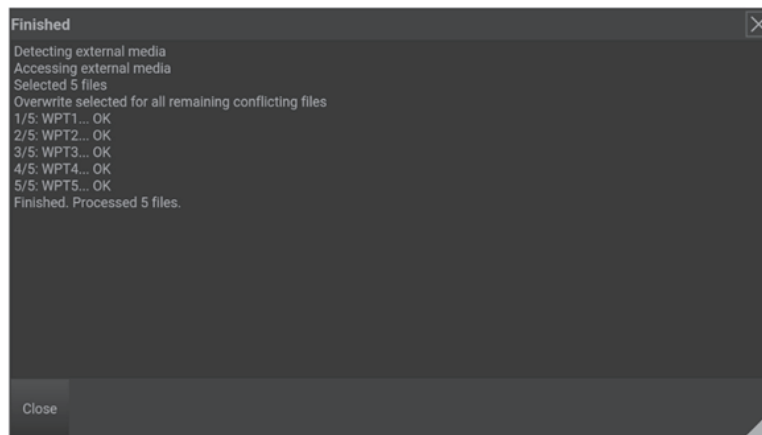

### 5.3.4 How to check a route

Tap [Route] and select [Settings] to open the [Route Settings] window. Select the [Route check] tab to check a route for safety. The route is automatically checked based on the route check parameters. You can select which chart objects trigger a graphical alert when deemed to be unsafe.

**Note:** See also subsection 5.4.3 for information about route check parameters.

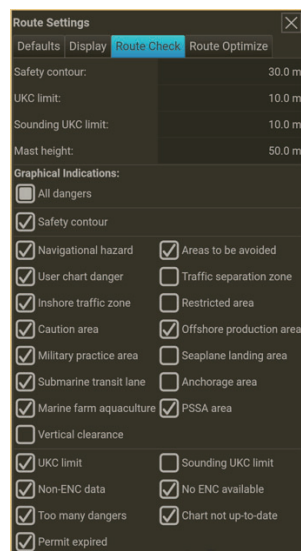

The [Check] column in the [Waypoints] list denotes problem waypoints with a color-coded square.

## 5. ROUTES

Route check results		Waypoints																		
*Route		Name	Position	RAD NM	XTD m	Margin m	PL m	GC/RL	Leg Course	Leg NM	Total NM	MIN kn	Speed kn	MAX kn	ETD/ETA (UTC)	Time Zone	DST	Draught m	Check	
WPT1	Safety contour	1	01°58.352'N 027°04.188'W		185	50		RL	230.3°	660.4	0.0	4.0		25.0						
	Restricted area	2	05°08.511'N 035°36.165'W	0.80	185	50		RL	068.1°	666.1	660.4	4.0		25.0		-03:00			5.0	
	Caution area	3	00°57.448'N 025°15.421'W	0.80	185	50		RL	111.4°	146.2	1326.5	4.0		25.0		-02:00			5.0	
WPT2	Safety contour	4	01°51.010'N 022°59.840'W	0.80							1472.6					-02:00				

To see detailed information about a check result, tap any WPT in the [Check] column to open the [Route check results] window. The window shows the problem for the waypoint selected. Color and safety concern level are as shown below.

- Green: nothing found
- Yellow: caution(s) found
- Red: safety contour warning

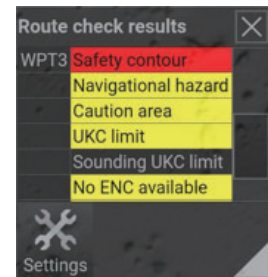

### 5.3.5 How to save a route

**Note 1:** If the route (or user chart) is currently being monitored or edited on the ECDIS/RADAR side, the route cannot be saved on the Planning Station. Tap the [Save As] button to save the route under a different name, or stop monitoring/editing on the ECDIS/RADAR side before saving the route.

**Note 2:** Maximum 63 characters can be entered for route name.

1. Tap the [Save] button on the [Edit Route] window to name the planned route.

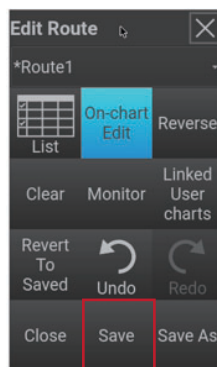

2. Enter the name for the route and tap the [OK] button to save.

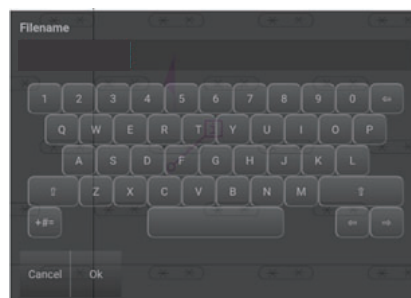

### 5.3.6 How to delete a route

Do as follows to delete a route.

**Note 1:** If the route is currently being monitored, edited or secured on the ECDIS/RA-DAR side, the route cannot be deleted at the Planning Station.

**Note 2:** Routes can also be deleted from the [Select Route] window.

1. Tap the [Route] button.
2. Select the [Delete] button to open the [Delete Routes] window.
3. Select the route(s) to delete and then tap the [OK] button.

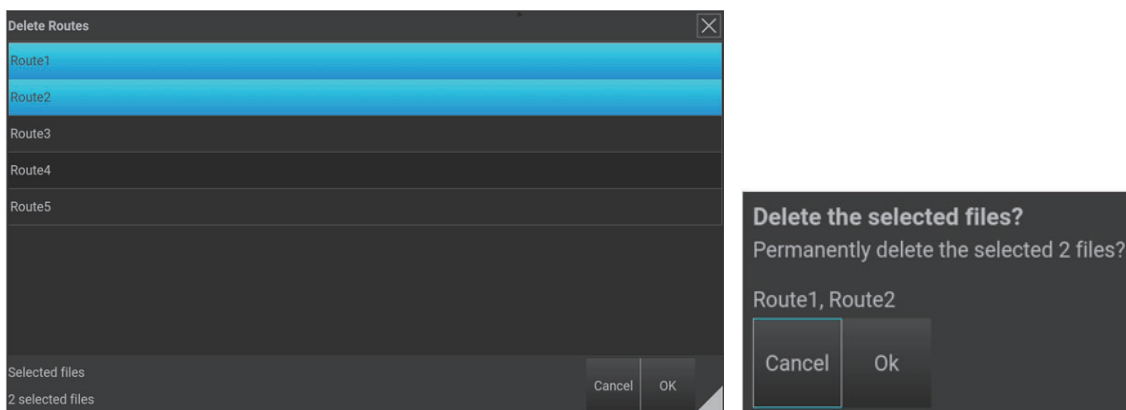

4. When the confirmation window appears, tap the [OK] button to delete the selected route(s).

## 5.4 How to Edit a Route

### 5.4.1 How to edit an existing route

**Note:** If the route is currently being edited, monitored or secured on the ECDIS/RA-DAR side, the route cannot be edited on the Planning Station.

1. Tap the [Route] button.
2. Tap the [Select] button.

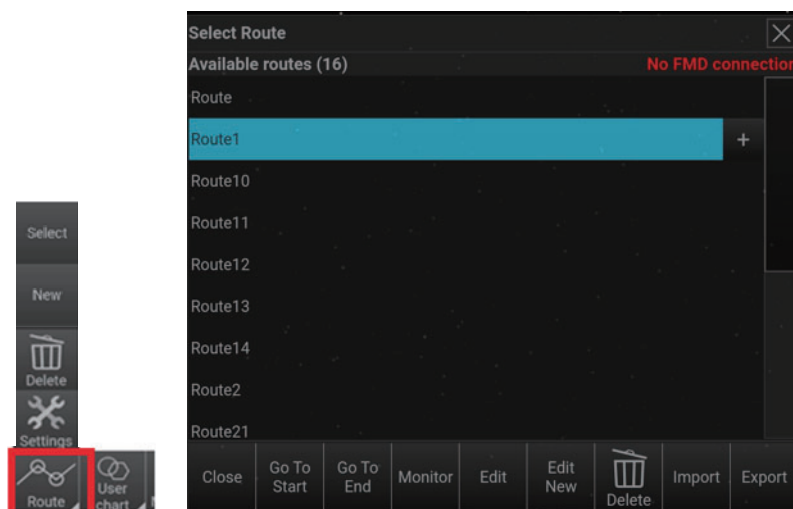

3. Select the route from the list and tap the [Edit] button.

### 5.4.2 How to edit multiple routes

**Note:** A maximum of ten (10) routes can be selected and edited at the same time. When the maximum number is selected, [Selected routes (max (10))] will be shown.

1. Tap the [Route] button.
2. Tap the [Select] button.
3. Select the desired routes and tap the [+] button on the right. The selected route names are shown in the [Selected routes] field at the bottom of the window. To remove a route, tap the [-] button.



4. In case multiple routes are selected, the active route can be set from the list at the upper part of the [Edit Route] window.

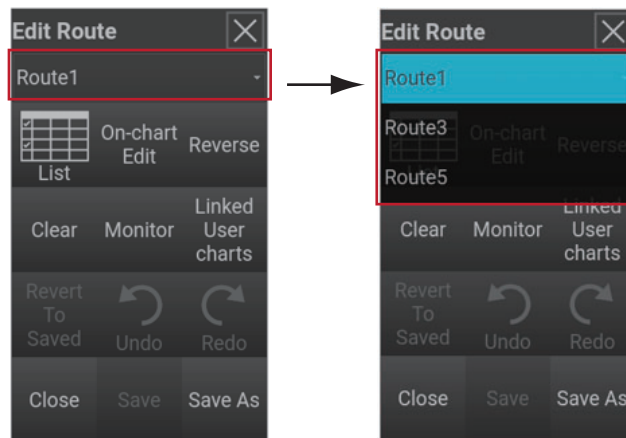

See the descriptions below for each available operations in the [Edit Route] window.

- [Reverse]: Change the route order.
- [Revert to Saved]: Revert to the status before the route was edited.
- [Clear]: Delete all waypoints set for the route.
- [Undo]: Undo the previous edit.
- [Redo]: Cancel the [Undo] operation.

### 5.4.3 How to set route-related parameters

Tap the [Route] button and select [Settings] to open the [Route Settings] window.

**Note:** See subsection 5.6.2 for the information about the [Route Optimize] tab.

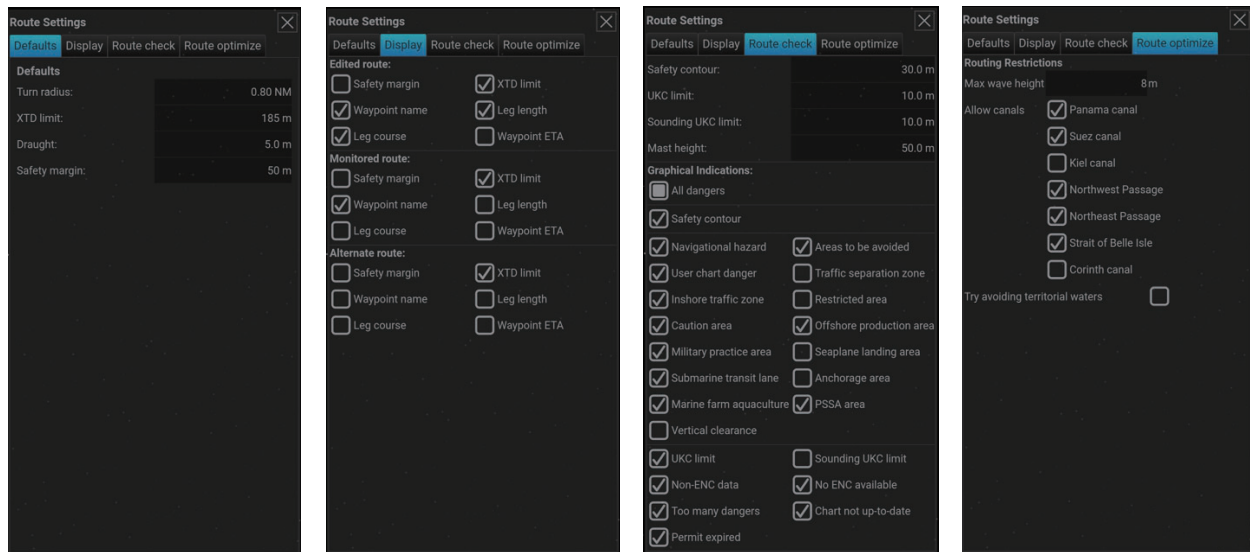

#### **[Defaults] tab**

Set values for turn radius, XTD limits, draught, and safety margins.

#### **[Display] tab**

Select which elements to show for planned and monitored routes.

#### **[Route check] tab**

Select the value (m) during route check. The setting range for each item is as below.

- [Safety contour]: 0.0 to 99.0 m
- [UKC limit]: 0.0 to 99.0 m
- [Sounding UKC limit]: 0.0 to 99.0 m
- [Mast height]: 0.0 to 200.0 m

Graphical indication items are as follows.

- [All dangers]
- [Safety contour]
- [Navigational hazard]
- [User chart danger]
- [Inshore traffic zone]
- [Caution area]
- [Military practice area]
- [Submarine transit lane]
- [Marine farm aquaculture]
- [Vertical clearance]
- [UKC limit]
- [Too many dangers]
- [Non-ENC data]
- [Areas to be avoided]
- [Traffic separation zone]
- [Restricted area]
- [Offshore production area]
- [Seaplane landing area]
- [Anchorage area]
- [PSSA area]
- [Sounding UKC limit]
- [No ENC available]
- [Chart not up-to-date]
- [Non-ENC data]
- [Permit expired]
- [Vertical clearance]

## 5.5 Monitor a Route

When a route is selected for monitoring, the own ship symbol appears on the chart. The [Route Info] window, which appears at the right upper corner, displays the information shown in the figure below. Route monitoring is stopped when sensor data is lost, and resumed once the data is restored.

**Note:** If the route is being edited on the ECDIS/RADAR side during the route monitoring on the Planning Station, the route monitoring will be forcibly stopped.

- [Route]: Route name.
- [State]: System state (monitoring).
- [To WPT]: Indicates the TO waypoint.
- [DIST to WOL]: Indicates distance to WOL (Wheel Over Line).
- [Time to WOL]: Time to WOL using current speed.
- [Off track]: Distance from center line (|→ =Right from center line, ←| =Left from center line).
- [Plan speed]: Planned speed.
- [Plan course]: Planned course of leg.
- [Next course]: Course after waypoint change.
- [DEST]: Name of the final waypoint.
- [Plan ETA]: Planned ETA to last waypoint.
- [ETA]: Estimated Time of Arrival to final waypoint.
- [Off Plan]: Time difference between [Plan ETA] and [ETA].
- [Distance]: Distance to the final waypoint.

Route Info	
Route:	HEL OUT
State:	Monitoring
To-WPT:	WPT002
DIST to WOL:	2.7 NM
Time to WOL:	15 min 21 s
Off track:	→ 330 m
Plan speed:	50.0 kn
Plan course:	246.0°
Next course:	257.8°
DEST:	WPT009
Plan ETA:	16:52:00+02
ETA:	15:33:57+02
Off plan:	1 h 18 min ahead
Distance:	91.5 NM

List    Stop    Edit

### 5.5.1 How to start route monitoring

1. Tap the [Route] button.
2. Tap the [Select] button.

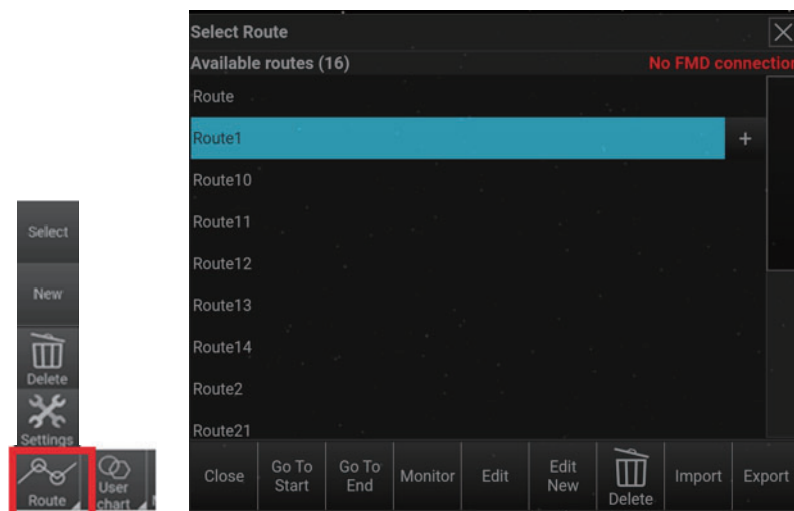

3. Select the route to monitor, then tap the [Monitor] button.

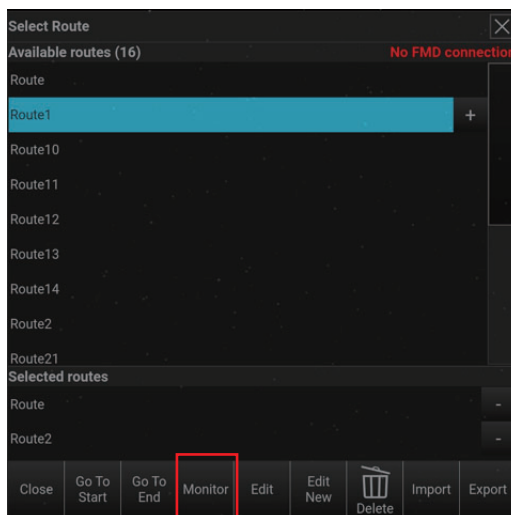

4. The [Route Info] window and shows the route information at the bottom right corner of the display.

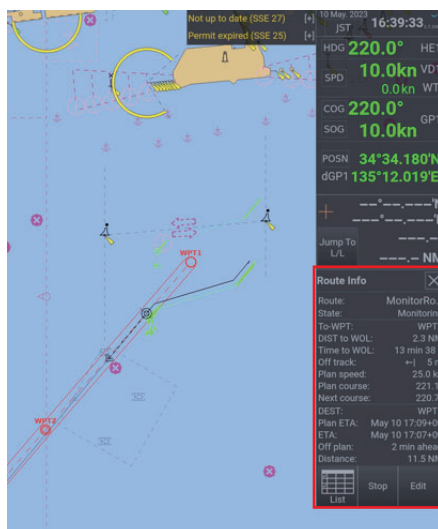

← [Route Info] window

5. The [Monitor Info] button is added to the [Route] bar. Tap to hide or show the route information.



← Tap to hide or show the [Route Info] window.

### 5.5.2 How to select ETA for a waypoint

The Planning Station automatically calculates Estimated Time of Arrival (ETA) as default to the final waypoint (WPT). If you want the ETA calculation for a waypoint other than the last waypoint, do as follows.

1. Tap the [Route Info] window to show the context menu.

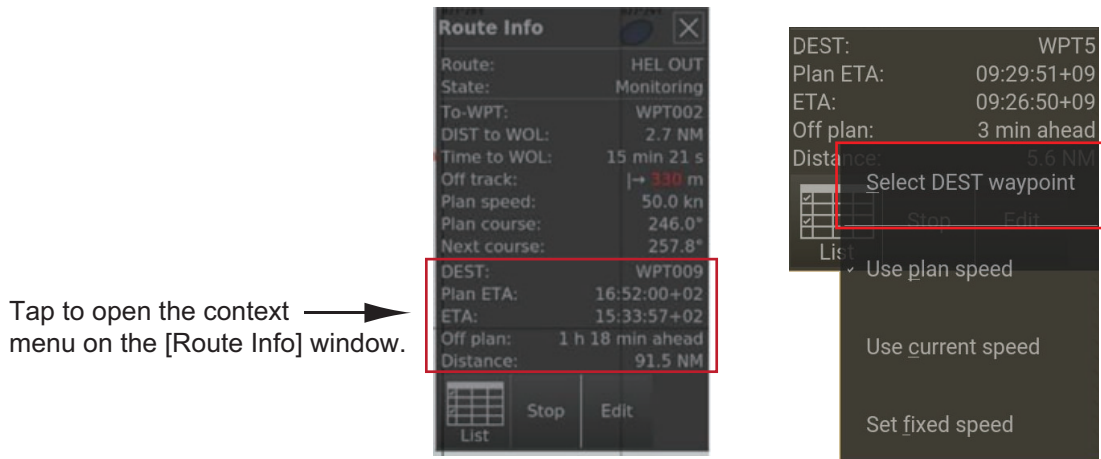

2. Tap [Select DEST waypoint] and select the desired waypoint.
3. Tap the [OK] button to view the ETA set for the selected waypoint.

### 5.5.3 How to calculate ETA with different speed profiles

The Planning Station automatically calculates the Estimated Time of Arrival (ETA) as default to the final waypoint (WPT) using the planned speed. Do as follows to change the ETA calculation method ([plan speed], [current speed], or [fixed speed]).

1. Tap the [Route Info] window to show the context menu.
2. Select a speed profile to the ETA for the waypoint.
3. If you selected [Set fixed speed], the software keyboard appears. Enter the speed value (kn) and tap the [OK] button.

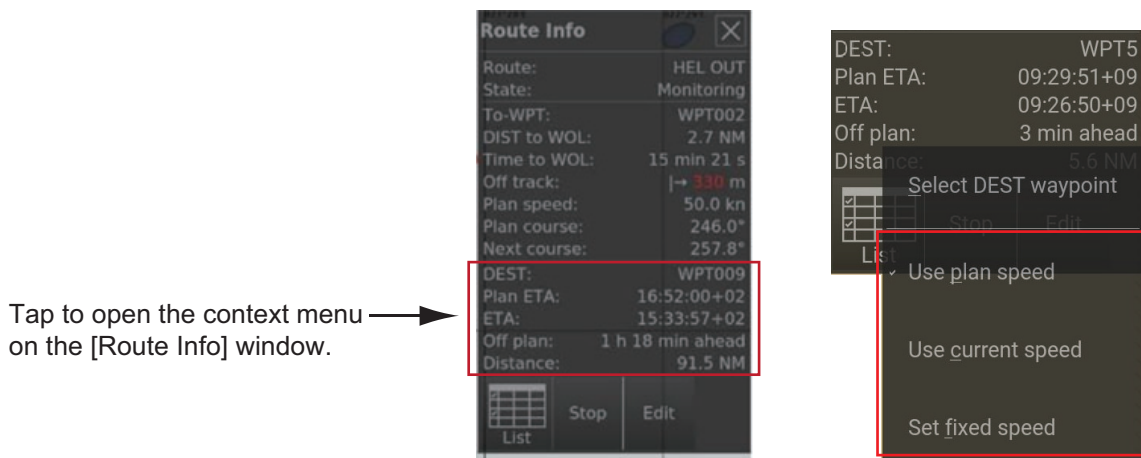



### 5.5.4 How to stop monitoring a route

In the [Route Info] window, tap the [Stop] button to stop monitoring the route.

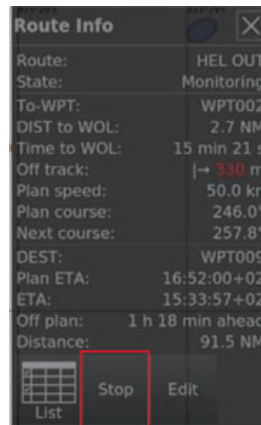

### 5.5.5 How to see a list of waypoints used in the monitored route

You can view a list of the waypoints used during route monitoring. Tap the [List] button inside the [Route Info] window to see the waypoints used.

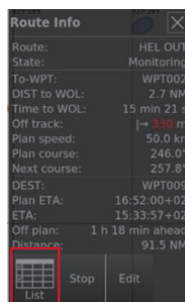

Tap [List] to open [Waypoints] window.



Name	Position	RAD NM	XTD m	Margin m	PL m	GC/RL	Lag Course	Lag NM	Total NM	MIN Speed kn	MAX Speed kn	ETD/ETA (Local)	Time Zone	DST	Draught m	
1	34°35.001'N 135°12.880'E		185	50		RL	221.1°	3.5	0.0	4.0	25.0	25.0	10 May 2023 16:39	+09:00	10	5.0
2	34°32.326'N 135°10.960'E	0.80	185	50		RL	220.7°	2.0	3.5	4.0	25.0	25.0	10 May 2023 16:47	+09:00	10	5.0
3	34°30.794'N 135°08.468'E	0.80	185	50		RL	216.5°	4.2	5.5	4.0	25.0	25.0	10 May 2023 16:52	+09:00	10	5.0
4	34°27.288'N 135°06.333'E	0.80	185	50		RL	194.6°	2.8	9.8	4.0	25.0	25.0	10 May 2023 17:02	+09:00	10	5.0
5	34°24.729'N 135°04.529'E	0.80							12.6				10 May 2023 17:04	+09:00	10	

### 5.5.6 How to edit the monitored route

You can edit the monitored route by tapping the [Edit] button inside the [Route Info] window. The [Select Operation] window appears.

**Note 1:** A route cannot be edited on the Planning Station if the monitored route on the Planning Station is the same as the route being monitored on ECDIS/RADAR. Therefore, the [Edit] button in the [Route Info] window will be replaced as [Edit Copy].

**Note 2:** If no operation is done in the [Select Operation] window for one minute, the operation is canceled.

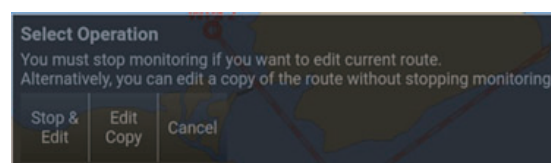
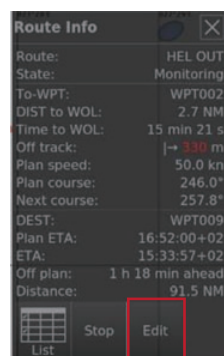

## 5. ROUTES

- [Stop & Edit]: Stop route monitoring and edit the route.
- [Edit Copy]: Copy the currently monitored route and edit. The [Edit Route] window appears and the route name is displayed as “\*XXXXXX\_copy” (XXXXXX= indicates the route name). If the copied route already exists, a number is inserted after the route name (ex. “Route1\_copy2”). The [On-chart edit] button is highlighted in blue.
- [Cancel]: Cancel and close the [Select Operation] window. Make necessary modifications to the route and tap the [Save as] button. Enter a name for the edited route. After saving the route, the [Monitor] button appears. To set the route as the monitored route, tap the [Monitor] button.

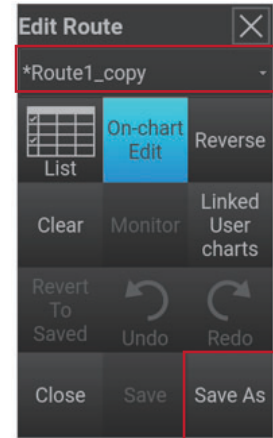

## 5.6 Route Optimizing (Option)

Route optimization is performed by the NAPA Voyage Optimization service, which is available with the optional chart service Gate-1. In this service, the NAPA server generates and distributes the optimal route based on information sent from the vessel, such as engine and hull characteristics. These information, along with weather information, are used to optimize a route required for navigation.

### 5.6.1 How to optimize a route

At least two waypoints (start and end points) are needed for route optimization. To optimize a route, do as follows.

1. Tap the [Route] button.
2. Do one of the following:
  - Tap [New] to show [Edit Route] window and set at least two waypoints on the chart to create a route.
  - Tap [Select] to choose one of the saved routes and then tap [Edit] to show the [Edit route] window.
3. Tap the [Optimize route] button to show the [Waypoints] list.
4. Select at least two waypoints from the list. You can also select multiple waypoints for the route optimization.

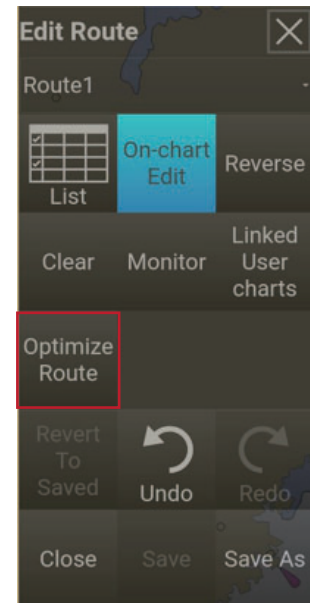

Route	Name	Position	RAD NM	XTD m	Margin m	PL m	GC/RL	Leg Course	Leg NM	Total NM	MIN kn	Speed kn	MAX kn	ETD/ETA (UTC)	Time Zone	DST	Draught m	Check
<input checked="" type="checkbox"/>	1	28°41.464'S 070°10.465'E		185	50		RL	086.9°	927.7	0.0	4.0	25.0		+05:00			5.0	
<input checked="" type="checkbox"/>	2	27°51.835'S 087°41.385'E	0.80	185	50		RL	209.3°	1081.7	927.7	4.0	25.0		+06:00			5.0	
<input checked="" type="checkbox"/>	3	43°38.091'S 076°46.393'E	0.80	185	50		RL	078.0°	603.2	2009.4	4.0	25.0		+05:00			5.0	
<input checked="" type="checkbox"/>	4	41°32.964'S 090°05.581'E	0.80	185	50		RL	027.6°	791.3	2612.6	4.0	25.0		+06:00			5.0	
<input type="checkbox"/>	5	29°50.334'S 097°36.902'E	0.80							3403.9				+07:00				

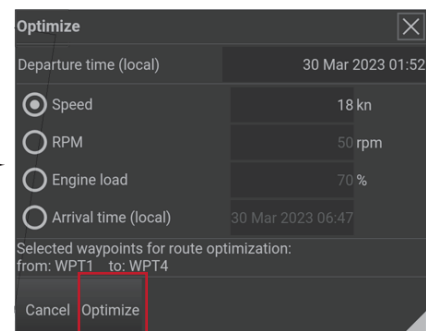

5. Set the optimize type (Speed, RPM, Engine load or Arrival time).
6. Tap the [Optimize] button to optimize the selected route. The route is sent to optimization service and the [Route Optimization] window appears.
7. When an optimized route is received by the Planning Station, the status of the route optimization changes to “completed” as shown below.



If the route could not be optimized correctly, one of the following messages appear. Contact your local FURUNO dealer.

- “Could not send optimization request to Gate-1”:  
Failed to send route optimization file by http request to Gate-1.
- “Gate-1 mount path not provided”:  
Missing Gate-1 optimization directory path (fetched from chart server).
- “Gate-1 IP address missing”:  
Missing Gate-1 address for http request.
- “Failed”:  
NAPA responded with error or PS-100 and Gate-1 failed to send request to NAPA.
- “Request timeout”:  
Optimization result was not received in given time limit. NAPA service was down or failed to parse optimization request file for unknown reason.

8. Tap the [Open] button to show the optimized route on the chart. To view the additional information of the optimized route service, tap the text symbol. If you want to delete the optimized route, tap the [Discard & Close] button.

Tap to open the optimized route on chart.

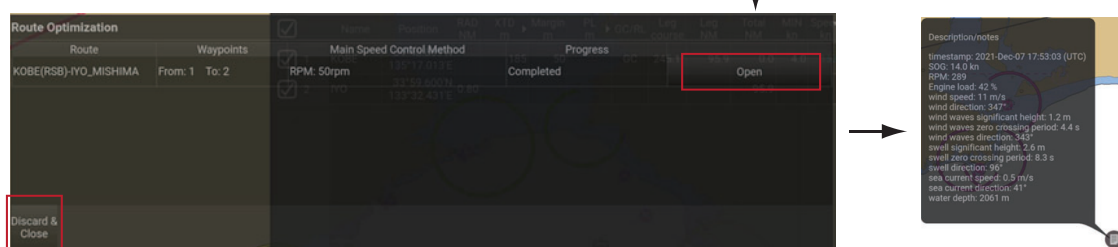

Tap to delete the optimized route.

Tap text symbol to show additional information of route optimization service.

## 5.6.2 Additional route optimization information

1. Tap the [Route] button.
2. Tap the [Settings] button to show the [Route Settings] window.
3. Tap the [Route Optimize] tab to see additional information and set desired options for route optimization. Also, maximum wave height range value can be adjusted (setting range: 2.0 m to 20.0 m). See the window on the right for available setting options.
4. Tap the [×] button to close the window.

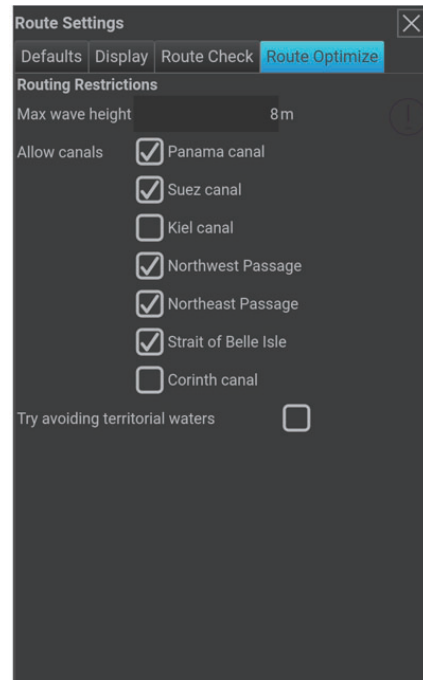

# 6. USER CHART

A user chart is an additional drawing made by the user on the chart. A user chart may contain the following objects: points, lines, areas, circles, tidal, clearing lines.

## 6.1 Create User Charts

1. Tap the [User Chart] button.
2. Tap the [New] button to show the [Edit Userchart] window.
3. Manage and add user chart objects on the chart as necessary. See the next subsection for how to add objects.

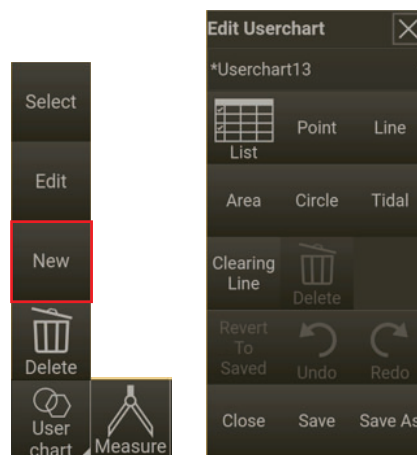

### 6.1.1 How to create objects for user charts

When creating objects, the values that can be set for each object is as follows.

- [Opacity]: Object transparency (0-75; default value: 20)
- [Line width]: Line thickness (1/2/3/4/5; default value: 2)
- [Orientation]: Tidal current direction (0° - 359°)
- [Time (UTC)]: Tidal current time ([hh/mm])
- [Strength]: Tidal current speed (0.0 to 10.0 kn; default value: 0)
- [Scale change (FMD)]: When the ship nears an object that has a scale value (0 to 70000; default value: 0) set for it, the scale value changes to the one set at the ECDIS side (see subsection 6.1.7 for details). This function is enabled on the ECDIS when synchronizing PS-100 with the ECDIS.
- [Range of notes]: When [E: when entering range] is set for a line object and when the distance between the ship and the line object, reaches the set value, the ECDIS side displays a message and switches the scale. The setting value is enabled on the ECDIS side when synchronizing with the Planning Station.

**Note:** In the [Usercharts Objects] window, you can enter multilingual multibyte characters for the each user chart object in the [Description] field. On the software keyboard, tap and hold the following characters to enter the multibyte characters; a, c, e, i, l, n, o, s, u, y, z, A, C, E, I, L, N, O, S, U, Y, Z.

**[Line] object**

1. Tap the [Userchart] button and select [New] to open the [Edit userchart] window.
2. Tap the [Line] button and add a line object on the chart (at least 2 points).

**Note:** You can also add a line object to the chart by free-hand.

3. Tap the [List] button on the [Edit userchart] window to open the [Userchart Objects] window. You can see and edit the created line object parameters and information.



Line object

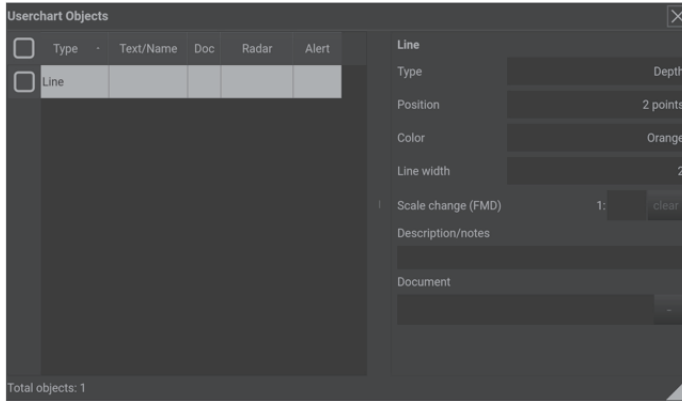

4. Tap the [Color] cell to change the color of the line object (options: red, green, blue, magenta, orange, brown, black, yellow).
5. Tap the [Type] cell to change the line type (options: Coast, Nav, Route, Depth).

**[Area] object**

1. Tap the [Userchart] button and select [New] to open the [Edit userchart] window.
2. Tap the [Area] button and add an area object on the chart (at least three (3) points).

**Note:** You can also add an area object to the chart by freehand.

3. Tap the [List] button on the [Edit userchart] window to open the [Userchart Objects] window. You can see and edit the created area object parameters and information.

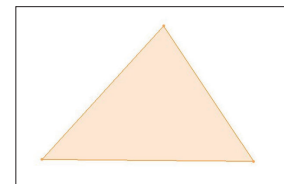

Area object

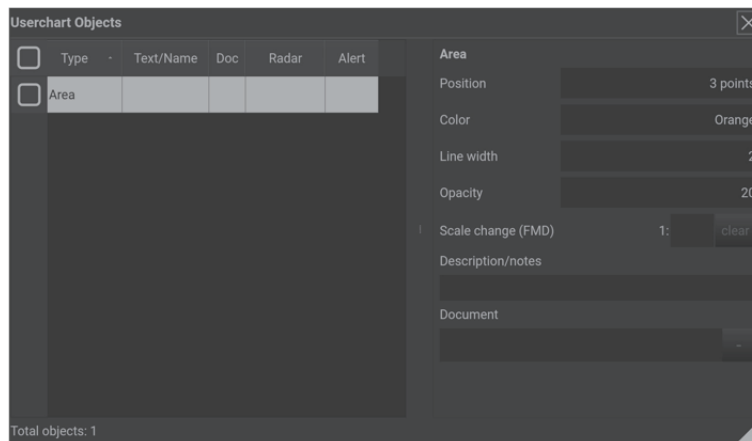

4. Tap the [Color] cell to change the color of the area object (options: red, green, blue, magenta, orange, brown, black, yellow).

**[Circle] object**

1. Tap the [Userchart] button and select [New] to open the [Edit userchart] window.

2. Tap the [Circle] button and add a circle object on the chart.  
**Note:** You can also add a circle object to the chart by free-hand.

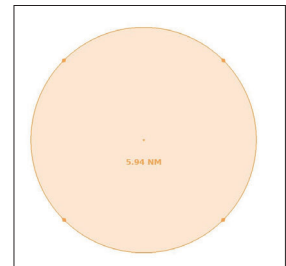

Circle object

3. Tap the [List] button on the [Edit userchart] window to open the [Userchart Objects] window. You can see/edit the created circle object parameters and information.

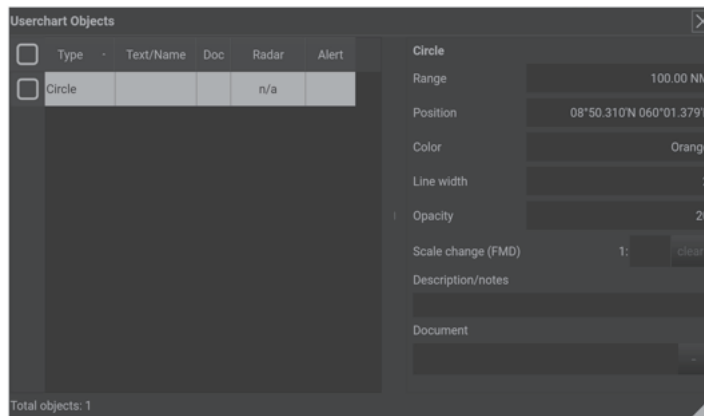

4. Tap the [Range] cell to adjust the range of the circle object (0.10NM to 100.00 NM).

5. Tap the [Change unit] button on the [Circle range] window to change the range unit between NM and m.

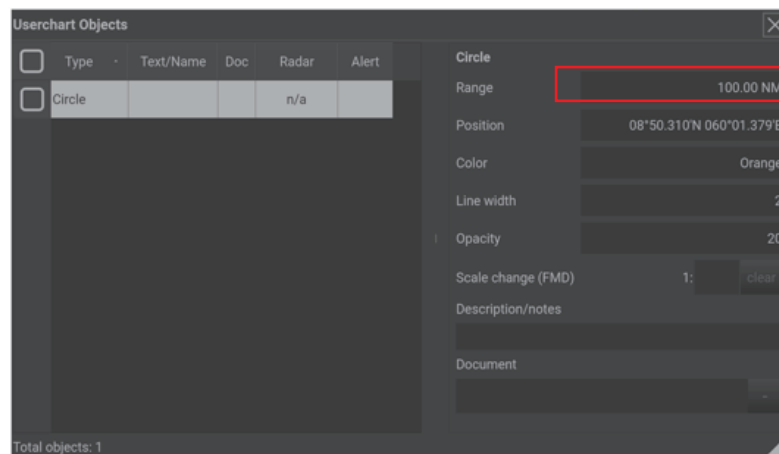
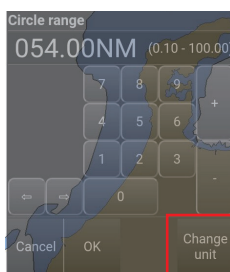

6. Tap the [Color] cell to change the color of the circle object (options: red, green, blue, magenta, orange, brown, black, yellow).

**[Point] object**

1. Tap the [Userchart] button and select [New] to open the [Edit userchart] window.
2. Tap the [Point] button and add a point object on the chart.
3. Tap the [List] button on the [Edit userchart] window to open the [Userchart Objects] window. You can see/edit the created point object parameters and information.



Point object

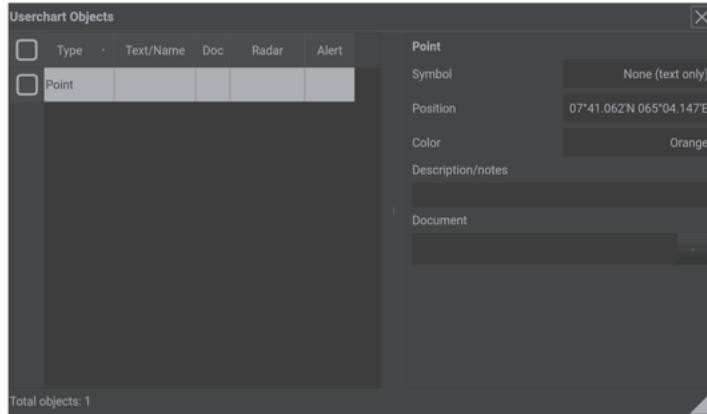

4. Tap the [Symbol] cell to change the point symbol appearance (options: None (text only), point, circle, triangle, diamond, pin).  
**Note:** The symbols that can be selected to display depends on the version of the user chart.
5. Tap the [Color] cell to change the color of the point object (options: red, green, blue, magenta, orange, brown, black, yellow).

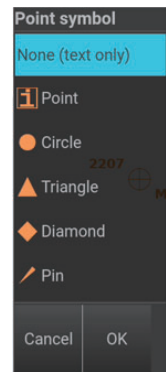

**[Tidal] object**

1. Tap the [Userchart] button and select [New] to open the [Edit user-chart] window.
2. Tap the [Tidal] button and add a tidal object on the chart.
3. Select the [Type] as [Current ] or [Predicted].
4. Tap the desired location on the chart to add a tidal object.  
**Note:** You can also add a tidal object to the chart by freehand.

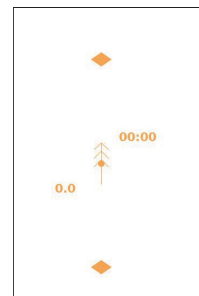

Tidal object



5. Tap the [List] button on the [Edit userchart] window to open the [Userchart Objects] window. You can see/edit desired parameters and information for tidal object.

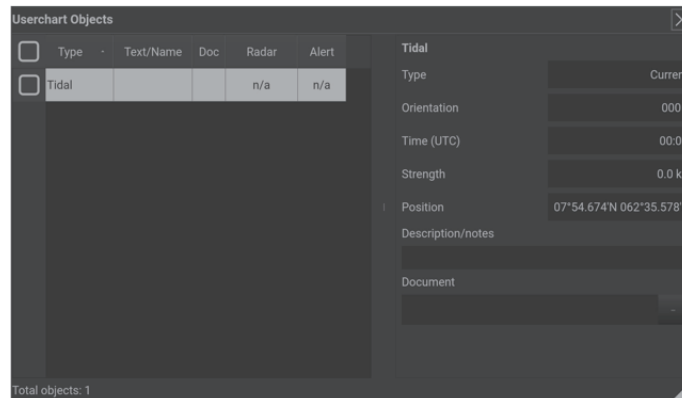

6. You can rotate a tidal object on the chart by dragging it from the diamond mark at the top/bottom part of the object.

### **[Clearing Line] object**

1. Tap the [Userchart] button and select [New] to open the [Edit userchart] window.
2. Tap the [Clearing Line] button and add a clearing line on the chart.  
**Note:** You can also add a clearing line to the chart by freehand.
3. Tap the [List] button on the [Edit userchart] window to open the [Userchart Objects] window. You can see/edit desired parameters and information for clearing line object.

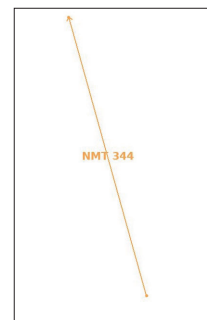

Clearing line object

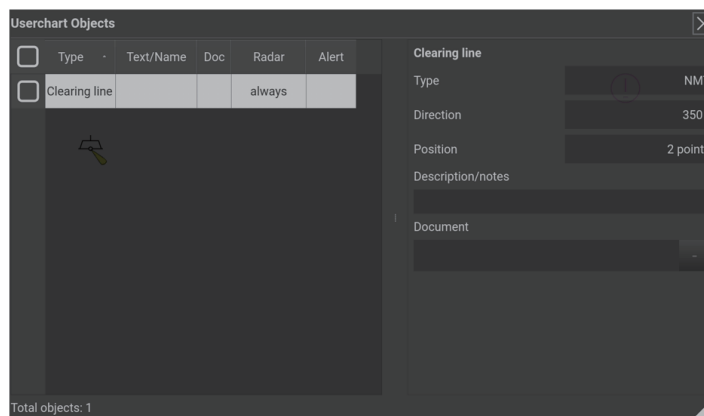

4. Tap the [Type] cell to change the clearing line type (NMT or NLT).

## **6.1.2 How to delete an added object**

1. Tap the [Userchart] button and select [Edit] to open the [Edit userchart] window.
2. Tap the [List] button to open the [Userchart Objects] window.
3. Tap the userchart object to delete, under the [Type] cell on the list.
4. On the [Edit userchart] window, tap the [Delete] button to delete the selected object from the list.
5. Tap the [Save] button.
6. Tap the [Close] button to close the window and finish.

### 6.1.3 How to add a document to a user chart object

Documents can be added to user chart objects (format: pdf, jpg, png, or txt).

1. Tap the [List] button on the [Edit userchart] window to open the [Userchart Objects] window.
2. Select a user chart object on the list and tap the [Document] or the [Doc] cell to show the [Select document] window.

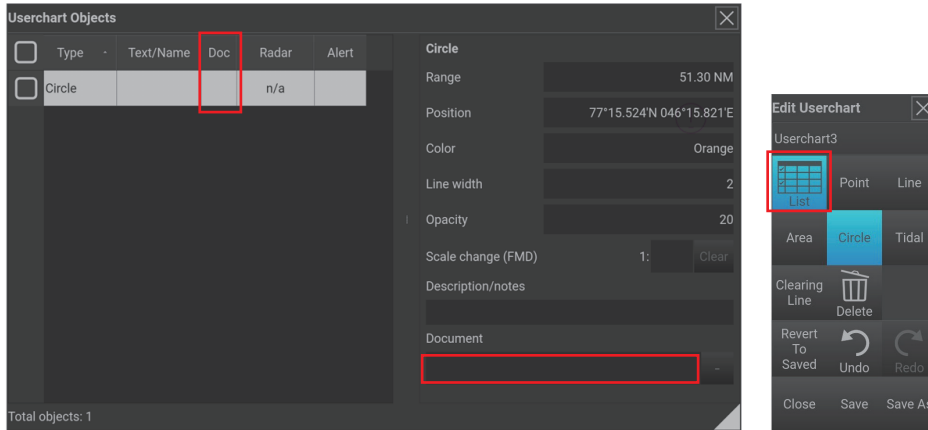

Tap to select a document.

3. Select desired document and tap the [OK] button to add document. The added document appears on the [Userchart Objects] window and as a text symbol on the chart.

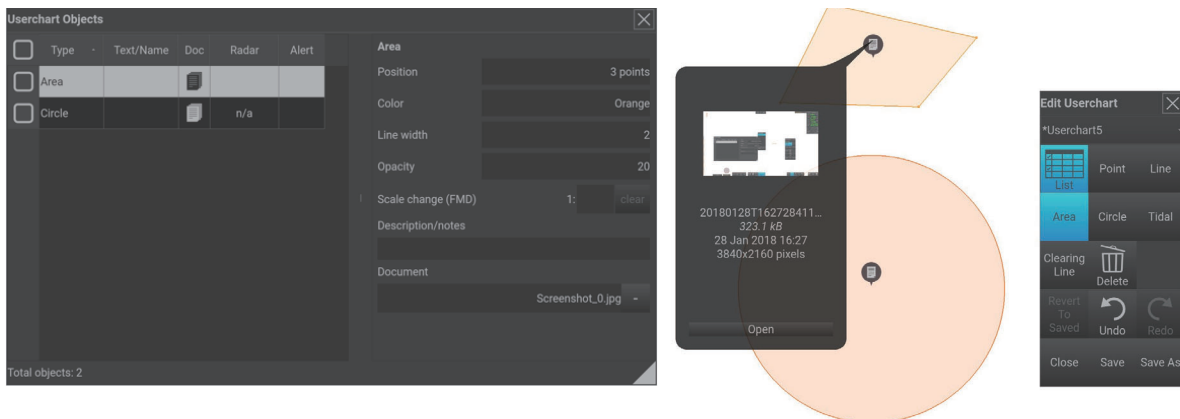

4. Tap the text symbol to see the document information. To open the document, tap the [Open] button. If the file data capacity exceeds 100M, the message "Please wait" appears.
5. To delete the added document, tap the [-] button of the document cell on the [Userchart Objects] window.

**Note:** If the deleted file is linked with [Userchart] and deleted from the list in the [Document] window (see chapter 12), the file will be deleted but the link remains.

In this case, the file will be displayed in red (  ) to indicate that the link is broken. Follow the above procedure to delete a file which is linked with [Userchart].

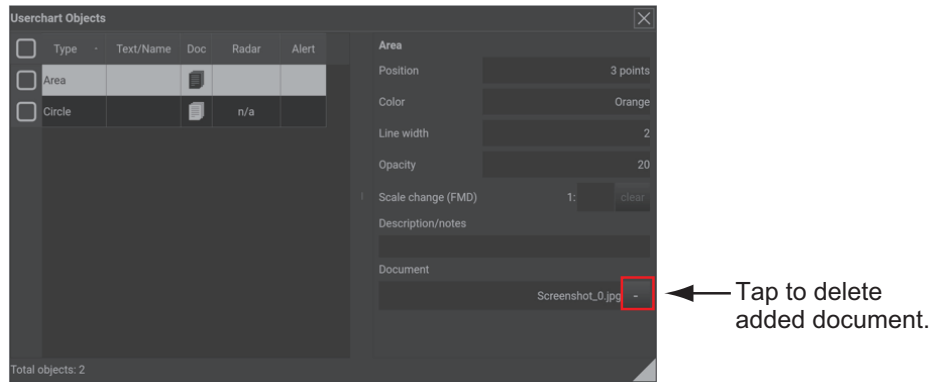

### 6.1.4 Context menu on the user chart object list

Tap the [User Chart] button and select [New] to open the [Edit Userchart] window. Tap the [List] button to show the [Userchart Objects] window. Put a checkmark in the checkbox of the object to process and then tap and hold (more than 1s) on the list to open the context menu shown below. The context menu provides the following functions.

**Note:** The options that are displayed on the context menu depend on the selected object.

- [Center chart to]: Center the user chart object on the chart.
- [Copy]: Copy the selected user chart object.
- [Copy selected objects]: Copy all the objects selected.
- [Delete]: Remove the selected user chart object from the list.
- [Delete selected objects]: Delete all the objects selected.
- [Paste]: Paste the copied object to the list (shown only when the object is selected as [Copy]).

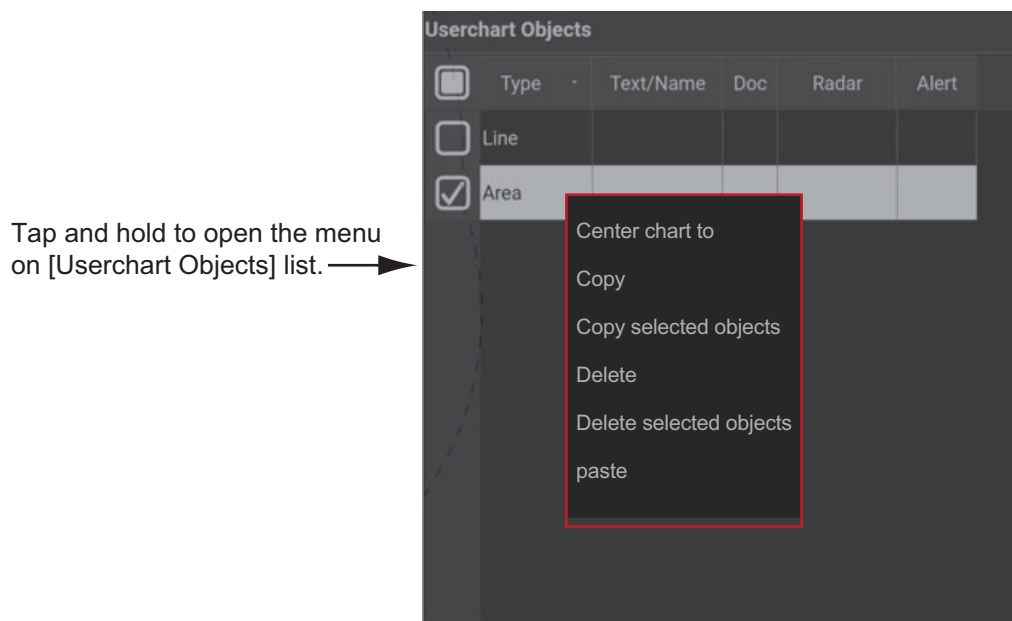

### 6.1.5 Alert settings

The available alert options change according to the selected user chart object. Available alert options are listed in the table below (default setting: [None]).

Object name	Alert options
[Line]	[None], [Danger], [E: when entering range]
[Area]	[None], [Danger], [E: When entering range], [P: when passing]
[Circle]	[None], [Danger], [E: When entering range], [P: when passing]
[Point]	[None], [Danger]
[Tidal]	[n/a] (this setting is fixed and cannot be changed).
[Clearing Line]	[None], [Danger]

- [Danger]: Determines whether or not the object is used based on the route check.
- [E: when entering range]: Displays a message when your ship is within the user-set distance to an object (area or circle). If the object is a line object, the message is displayed when the vessel is X miles away from the noted location (The X value is set in the [Range or notes] cell). The ECDIS must be connected to use this function.
- [P: when passing]: A message is displayed when the vessel is within 10 NM from the set object (area or circle). The ECDIS must be connected to use this function.

To set an alert for a user chart object, do as follows.

1. Tap the [User chart] button and select [New] to open the [Edit Userchart] window.
2. Tap the [List] button to show the user chart object list.  
**Note:** See also subsection 6.1.1 for how to add a user chart object to the chart,
3. Tap the alert cell to open the [Alert] window.

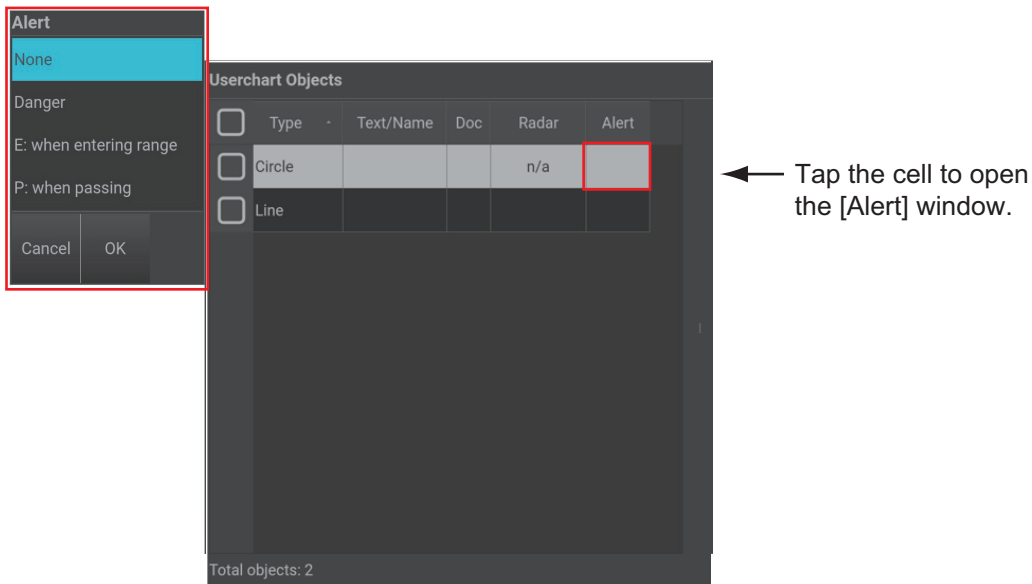

4. Set the desired alert and tap the [OK] button.

- The selected alert appears on the Alert cell.

<input type="checkbox"/>	Type	Text/Name	Doc	Radar	Alert
<input type="checkbox"/>	Circle			n/a	Danger
<input type="checkbox"/>	Line				

Total objects: 2

- Tap the [Save] button on the [Edit Userchart] window. A window to enter the file name appears.
- Enter the file name.
- Tap the [Close] button on the [Userchar Object] window to finish.

### 6.1.6 Radar settings

Set whether to show selected user chart object on the radar display (default: [No]).

- Tap the [User chart] button and select [New] to open the [Edit Userchart] window.
- Tap the [List] button to show the [Userchart Objects] list.
- Tap the radar cell to open the [Radar display] window. Select [Yes] or [No] as desired.

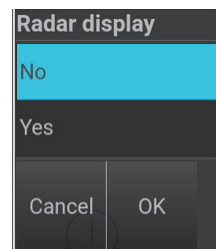

**Note 1:** For [Circle] and [Tidal] objects; [n/a] is fixed for radar settings and cannot be changed.

**Note 2:** For [Clearing Line] object; [Always] is fixed for radar settings and cannot be changed.

## 6. USER CHART

### 6.1.7 Scale display on the ECDIS to the object

The ECDIS FMD-3xxx scale value can be adjusted for [Line], [Area] or [Circle] user chart objects.

1. Tap the [Scale change (FMD)] cell on the [Userchart Objects] window to show the [Display scale change x 1000 (FMD)] setting window.
2. Set the value (setting range: 0 to 70000, default value: 0).
3. To reset the set value, tap the [Clear] button.

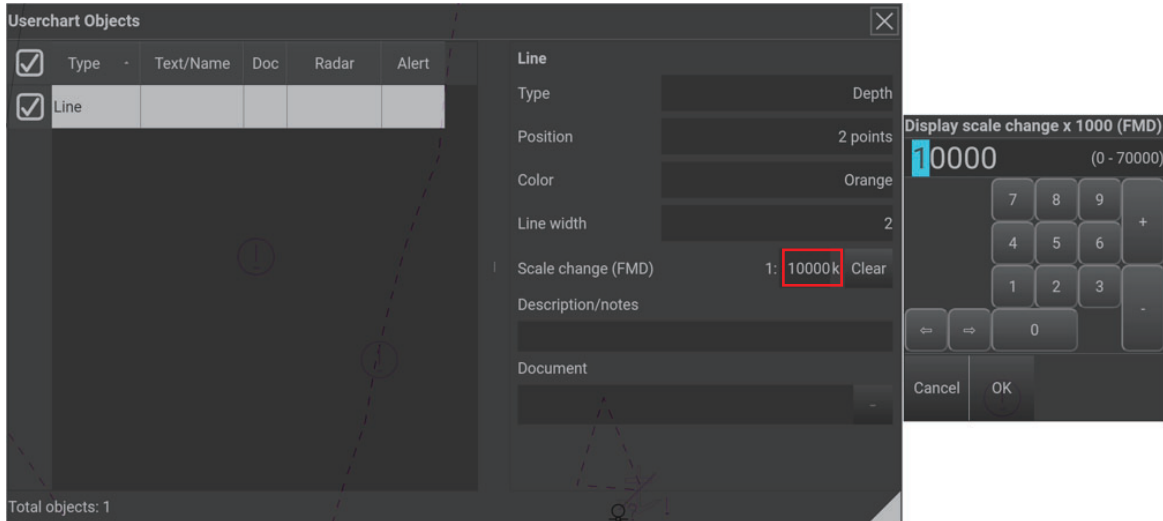

## 6.2 How to Manage User Charts

### 6.2.1 How to select a user chart

**Note:** Up to ten (10) user charts can be selected and edited at the same time. When the number of selected usercharts reaches the limit, the [Selected usercharts (max 10)] is displayed on the window.

1. Tap the [User Chart] button and then tap the [Select] button.
2. Select desired user chart from the [Select Userchart] window.

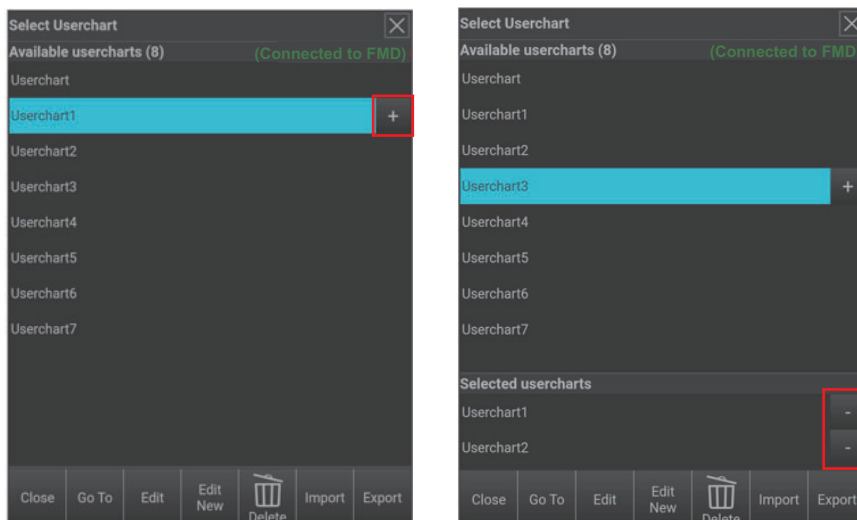

- To select multiple user charts, tap the [+] button on the [Select Userchart] window. You can see which charts have been selected below [Selected usercharts]. To remove a user chart, tap the [-] button.

## 6.2.2 How to save a user chart

Tap the [Save] button on the [Edit userchart] window (see section 6.1). The software keyboard appears. Enter the filename (max. 63 letters) for the user chart and tap the [OK] button to save.

**Note:** A user chart cannot be saved if it is currently being monitored or edited at the ECDIS/RADAR.

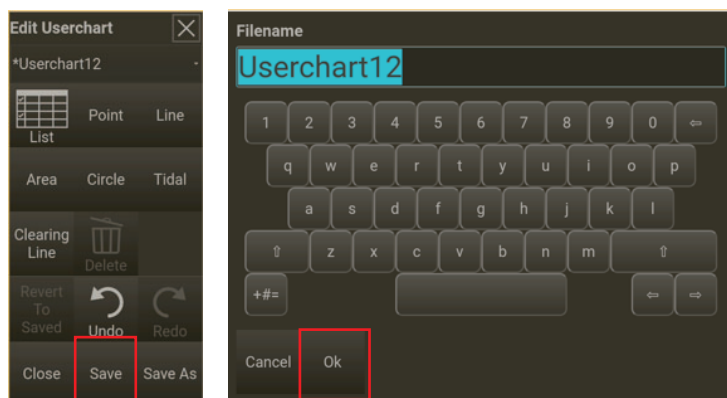

### 6.2.3 How to delete a user chart

**Note:** User charts can also be deleted from the [Select Userchart] window.

1. Tap the [User Chart] button and then tap the [Delete] button to open the [Delete Usercharts] window.
2. Select the user chart(s) to delete and tap the [OK] button.

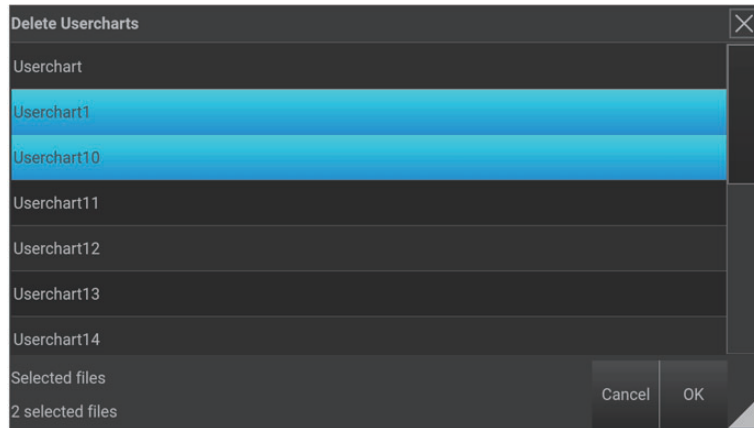

3. The message “ Delete the selected files? “ appears. Tap the [OK] button to delete.
4. Tap the [Close] button to finish.

### 6.2.4 How to switch between editing a route and a user chart

If you have both a route and a user chart displayed, you can switch editing between the two using the dialog boxes shown below. Tap the [Route] or [User Chart] button and select desired route/user chart from the list. To link a user chart to a route, tap the clip button. When a user chart is linked to a route, the clip button is shown in blue. A maximum of five (5) user charts can be linked with a route. When the limit is exceeded, the clip button is grayed out. See also subsection 5.3.1.

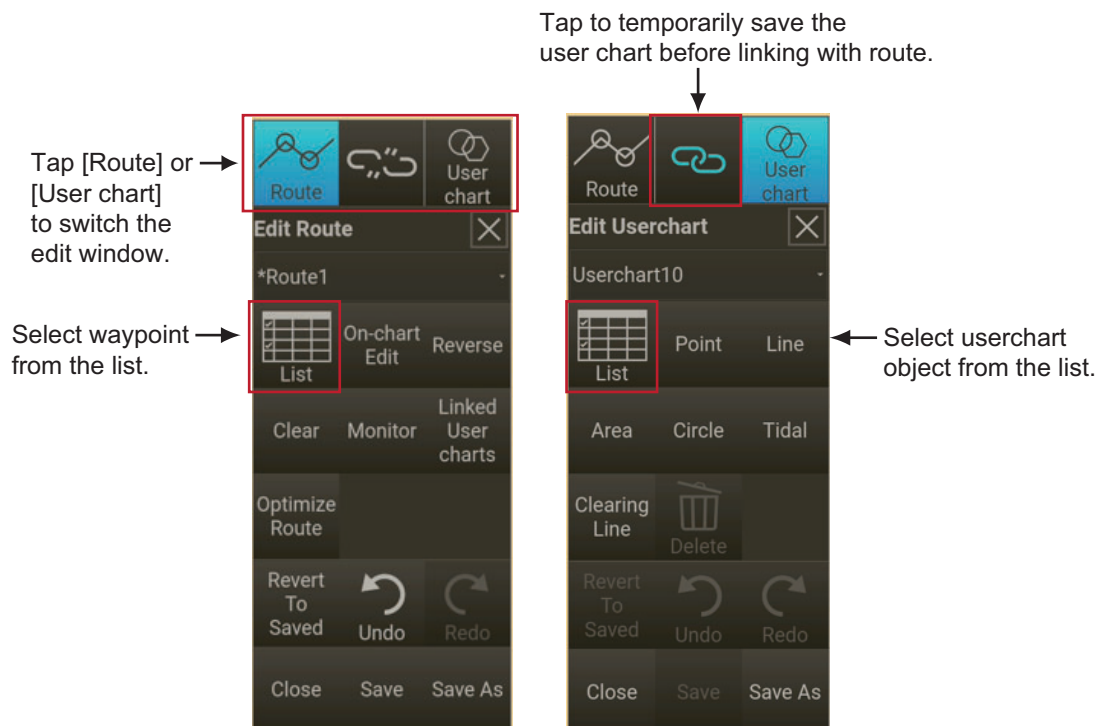



# 7. TARGETS

## 7.1 Introduction

AIS targets from an AIS transponder and Tracked Targets (TT) from a radar can be shown on the Planning Station. Requires connection of Furuno ECDIS in the same network as the Planning Station.

### Target symbols

TT and AIS targets appear as shown in the figure below.

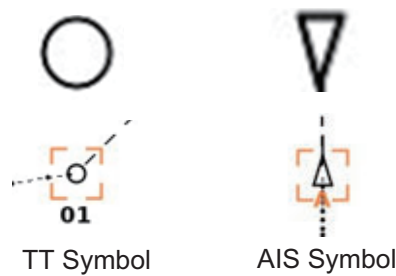

Symbol name	Symbol	Description
Sleeping AIS		Displays the AIS targets in sleep mode. The AIS symbol in sleep mode is displayed smaller than the active AIS symbol.
Activated AIS		Displays the active AIS targets. The active AIS symbol is displayed larger than the AIS symbol in sleep mode. The vessel's name appears below the symbol.
AIS SART		Displays the AIS SART targets.
SAR Aircraft		Displays the Aircraft in SAR (Search and Rescue).
Physical AtoN		Displays the actual AIS beacons.
Virtual AtoN		Displays the virtual AIS beacons.
SAR Vessel		Displays the SAR (Search And Rescue) vessels.
Activated SAR vessel		Tap the SAR vessel symbol to activate. The symbol appearance changes as shown to the left.

## 7.2 Target Symbol Display Settings

The symbol color and past track length of AIS targets and TT can be changed. Tap the [Target] button and select [Settings]. From the drop down list, the desired color for target symbols can be selected. Refer to the descriptions below to change color and past track length.

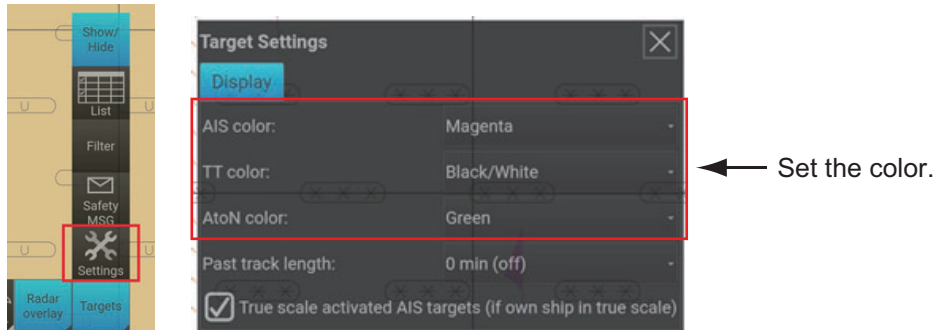

- [AIS color]: Change the color of the AIS symbol (Options: Green, Blue, Black/White, Magenta, Brown).
- [TT color]: Change the color of the TT symbol (Options: Green, Blue, Black/White, Magenta, Brown).
- [AtoN color]: Change the color of the AtoN symbol (Options: Green, Blue, Black/White, Magenta, Brown).
- [Past track length]: Change the length of past track for AIS and TT targets (Options: 0 min (off), 1, 5, 10, 15, 20, 30 minutes, 1 hours).
- [True scale activated AIS targets (if own ship in true scale)] check box: Check to show the symbols of active AIS targets in true scale.

## 7.3 Tracked Targets

Tracked Targets (TT) are received from the ECDIS network.

### Source of tracked targets

If more than one radar is connected to the ECDIS network, you can select the source of TT as follows: Tap the [Targets] button and select [Filter]. Select from the drop down list the radar you want to use as the source of TT (see also section 7.4).

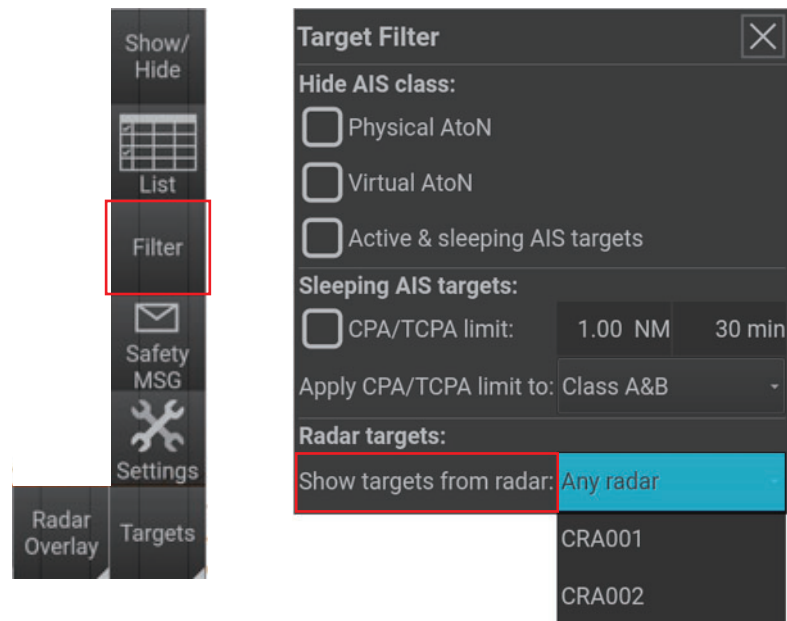

### Information about TT

To get detailed information about a TT (Tracked Target), tap and hold the TT symbol on the chart to show the context menu and select [Target Info] to open the [TT Info] window, an example of which is shown right.

**Note:** The information for a maximum of ten (10) tracked targets can be displayed at the same time.

TT Info	
Name:	02
Radar:	CRA001
Bearing:	290.0°
Range:	1.00 NM
COG:	045.0°
SOG:	12.0 kn
CPA:	10.0 NM
TCPA:	2 min 0 s

## 7.4 AIS Targets

To get detailed information about AIS targets, tap and hold an AIS target symbol to show the context menu and then select [Target Info] to open the [AIS Target [\*]] window, an example of which is shown in the figure below. Check the “Show additional info” checkbox to show detailed information about an AIS target. To switch between activated and sleep mode, tap the AIS symbol on the chart.

**Note:** The information for a maximum of five (5) AIS targets can be displayed at the same time. Depending on the amount of displayed target information, in the [AIS Target[\*]] window, the asterisk (“\*”) is replaced with [A] to [E].

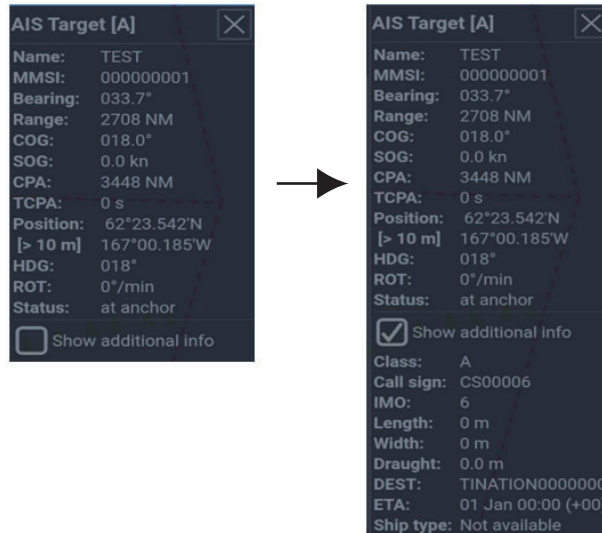

### AIS target outline display

Tap the [Targets] button and select [Settings] to open the [Target Settings] window. Select the [True scale activated AIS targets (if own ship in true scale)] check box to display the outlines of the activated AIS target(s). The chart must be zoomed in sufficiently to view the outlines.

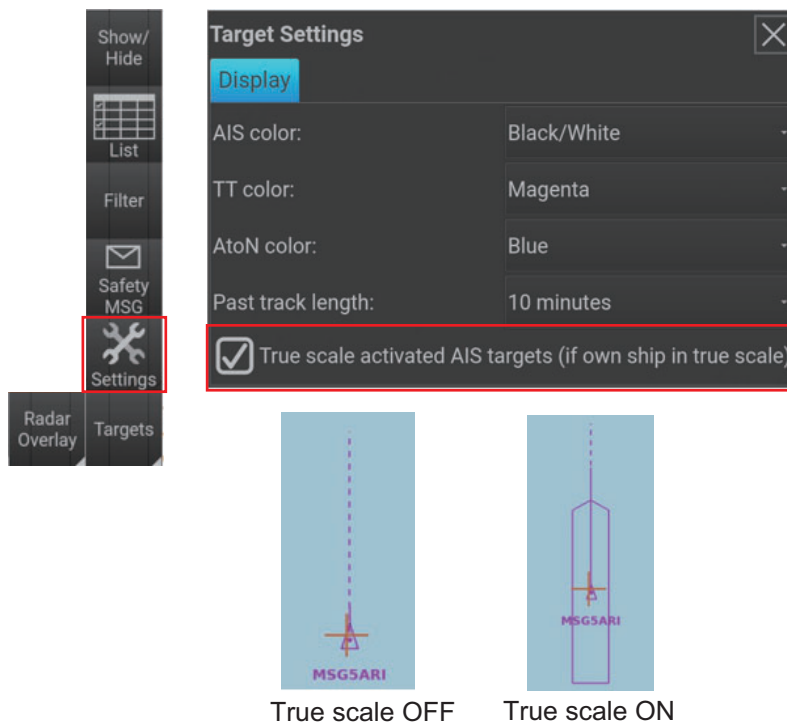

### How to filter AIS targets

AIS targets can be filtered by using the CPA/TCPA limit. Tap the [Targets] button and select [Filter] to open the [Target Filter] window. Put a checkmark for the items to hide. Tap the [X] button to finish.

- [Physical AtoN]: Show or hide physical AtoN.
- [Virtual AtoN]: Show or hide virtual AtoN.
- [Active & sleeping AIS targets]: Show or hide activated/sleeping AIS targets.
- [CPA/TCPA limit]: Set the filter for CPA (Closest Point of Approach, setting range: 0.00 to 99.99 NM) and TCPA (Time to Closest Point of Approach, setting range: 1 to 60 min) and set the distance and time. AIS targets are filtered when the set value for CPA/TCPA limit is met.
- [Apply CPA/TCPA limit to]: Set the AIS class to hide. (Class A&B, Class A or Class B, default: Class A&B)
- [Show targets from radar]: The radar settings source for the displayed TT information (default: [Any radar]).

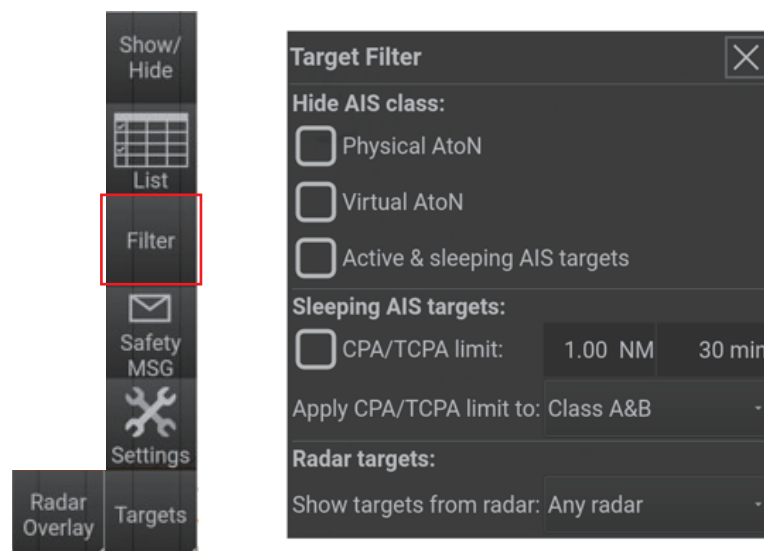

## 7.5 Target List

Tap the [Targets] button and select the [List] to show the [Target List] window. Switch between the AIS and TT target list displays to modify the TT or AIS target settings.

**Note:** in the AIS list, only Class A or Class B AIS targets are displayed. SAR Aircraft, AIS SART, Physical AtoN, and Virtual AtoN are shown on the chart but not in the list.

## 7. TARGETS

Tap to switch between AIS and TT target list.

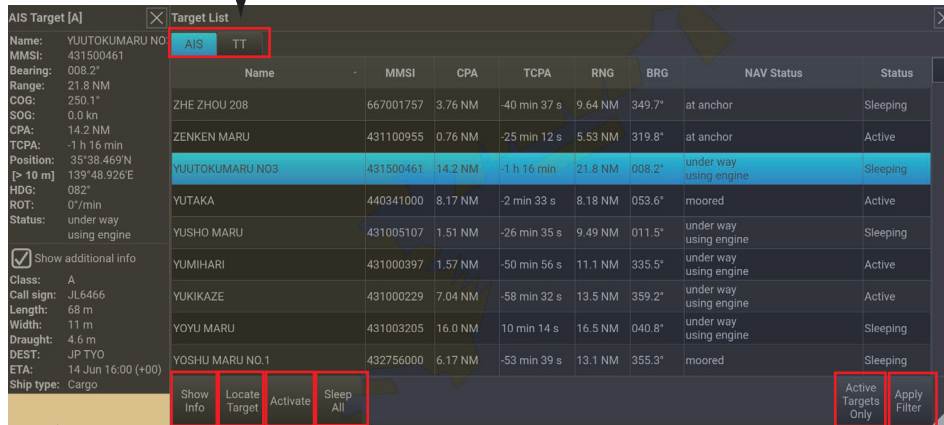

Tap to show information display.

Locate the target on chart.

Change the status of selected target between [Sleeping] and [Active].

Change status of all targets to [Sleeping].

Tap to show only active targets on the [Target List].

Apply and display the [Target Filter] settings.

## 7.6 AIS Safety Messages

You can view AIS safety messages received from an AIS transponder, on the Planning Station. To show AIS safety messages, tap the [Targets] button and then tap the [Safety MSG] button to open the [Safety Messages] window. The unread messages are indicated with a yellow envelope icon. The safety messages are saved for 90 days when received. To delete a message, check the check box of the desired message and tap the [Delete] button.

**Note 1:** As shown in the figure below, the envelope symbol appears on the [Targets] button when you have an unread safety message.

**Note 2:** The safety messages can also be viewed from the [Target Info] window of the received AIS. Tap the message in the [Target Info] window to show the [Safety Message] window.

Unread messages →

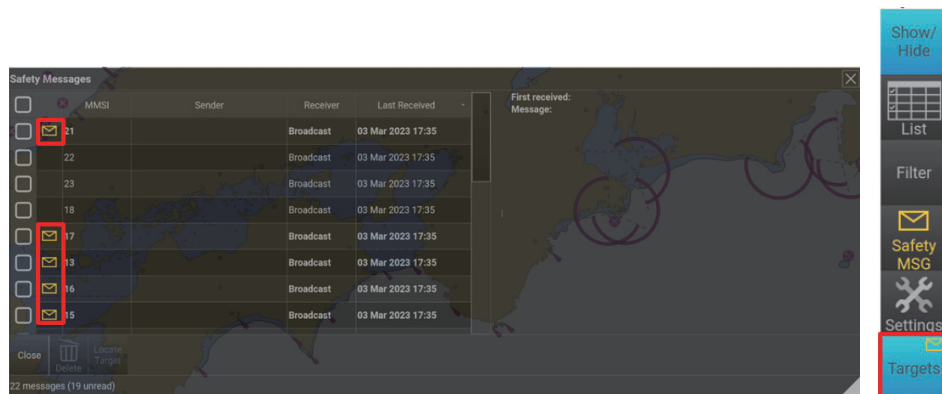

# 8. TOOLS

## 8.1 EBL/VRM

### 8.1.1 How to activate EBL/VRM

The EBL (Electronic Bearing Line) and VRM (Variable Range Marker) measure the range and bearing to an object, respectively. The system has three each of EBLs and VRMs. Do the following to activate an EBL, VRM.

1. Tap the [Measure] button to show the [Measure] window.

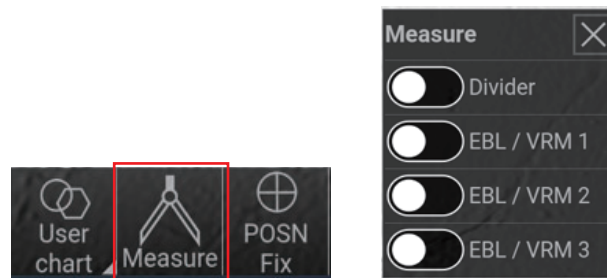

2. Tap desired EBL/VRM to adjust. Selected EBL/VRM is highlighted in blue when activated and bearing/range indications appear on the window (tap again to disable).

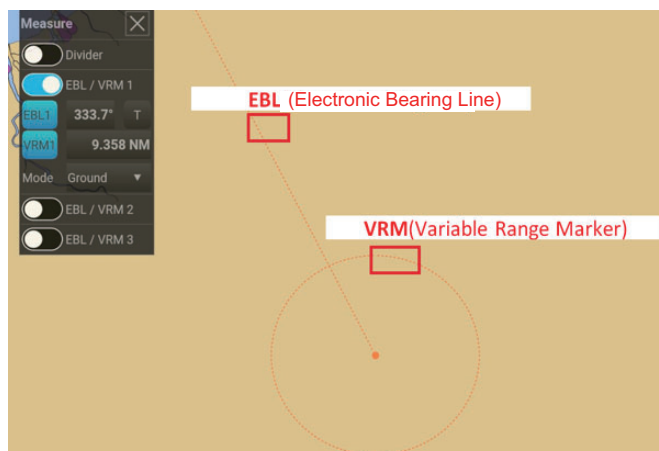

3. Tap the EBL field to adjust the EBL. Change the value manually by entering a numerical value, or set the value from the chart by tapping the [Select on Chart] button and tapping the desired bearing on the chart.

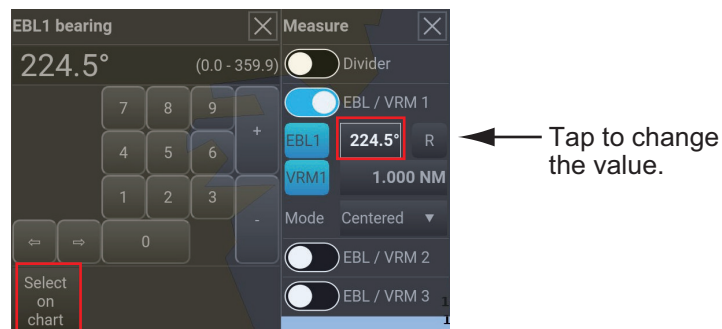

## 8. TOOLS

4. Tap the [T] field to switch the own ship's heading between true ([T]) and relative ([R]).
5. Similarly, set the VRM value.

### 8.1.2 How to change range unit for the VRM

The range unit for the VRM can be selected to m (meters) or NM (nautical miles).

1. Tap the EBL/VRM field on the [Measure] window to open the window below.
2. Tap the [Change unit] button or the range unit indication in the VRM field to change the range unit.

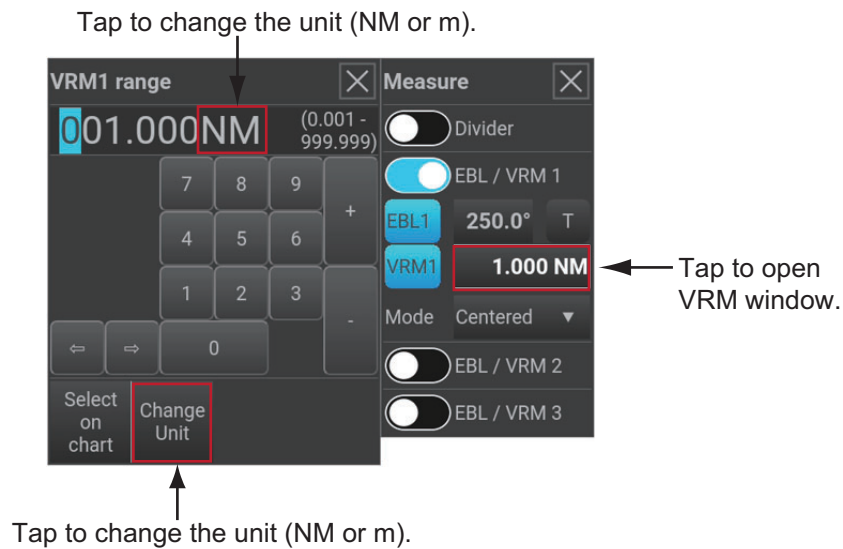

### 8.1.3 Ship and ground fixed EBL/VRM

You can select the mode for how to fix the EBL/VRM measurement ([Centered] or [Ground]). Tap the [Mode] selection to open the menu.

- [Centered]: Range and bearing are measured from own ship position.
- [Ground]: Range and bearing are measured from the set location on the chart.

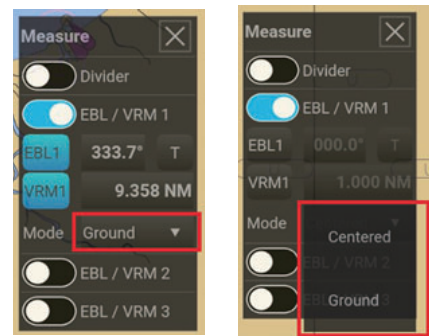



## 8.2 Divider

The divider measures the distance between two or more points. To activate the divider, tap the [Measure] button and then tap the [Divider] button on the [Measure] window. Tap the start point and then tap the end point on the chart. To add more than two (2) points, tap the [Add Points] button and add point on the chart.

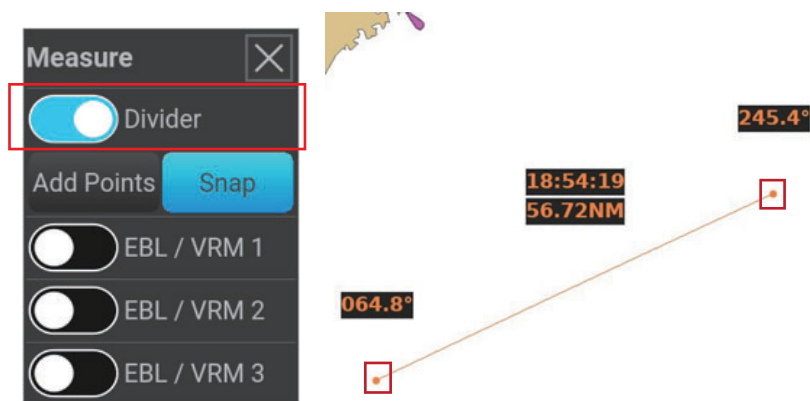

**Note:** You can see the direction from both points, the distance between points, and the time to go with current speed.

### 8.2.1 Divider slider function

Tap and hold the divider line to display the context menu shown in the figure below.

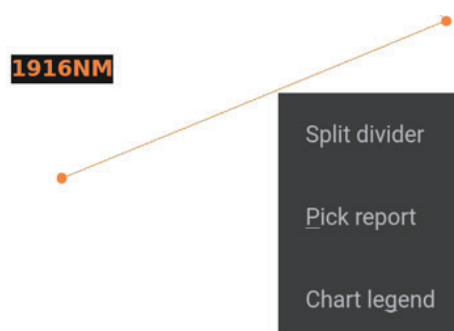

Tap [Split divider] on the menu. A circle appears at the center of the divider line as shown in the figure below. The distance between the circle and the end point is displayed. You can also change the position of the circle by dragging it.

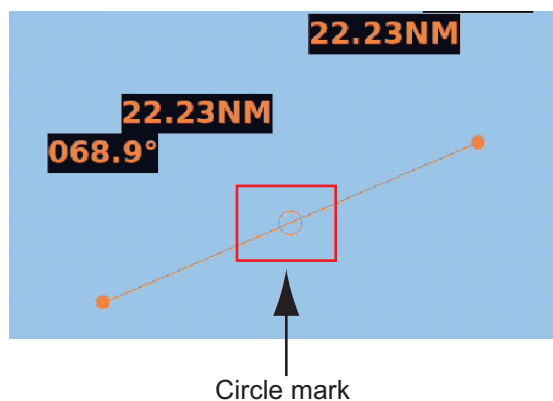

To erase the circle, tap and hold the circle and select [Join divider] to erase.

### 8.2.2 Snap function

The snap function lets you attach the points of the divider to objects. To use the snap function, turn on the divider (see section 8.2), then tap the [Snap] button. Drag the divider onto a chart object, and that divider point "snaps" to the chart object. The available objects are shown in the figure below.

#### Applicable objects

- Own ship symbol (CCRP position)
- AIS symbol
- TT symbol
- Chart object (Buoy, pilot boarding place, obstruction, etc.)
- Route waypoint
- User Chart - [Point] object
- Position fixing mark

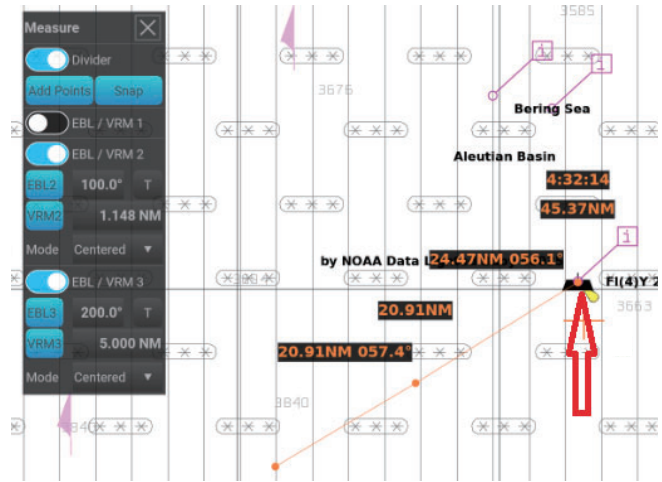

#### Not applicable objects

- Chart objects (Sounding, anchor berth, radio calling-in point etc.)
- Monitored route waypoints

## 8.3 Tidal Information (Available In the Future)

**Note:** This function will be available in the future.

The Planning Station can display tidal information, available from the UKHO's Admiralty Digital Product (ADP) server. For further information, contact your local Furuno dealer.

1. Tap the [System] button and select [Settings] to open the below [Settings] window.

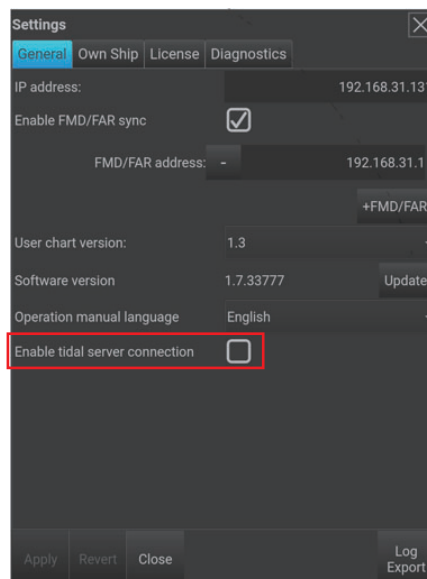

2. Check the [Enable tidal server connection] on the check box.

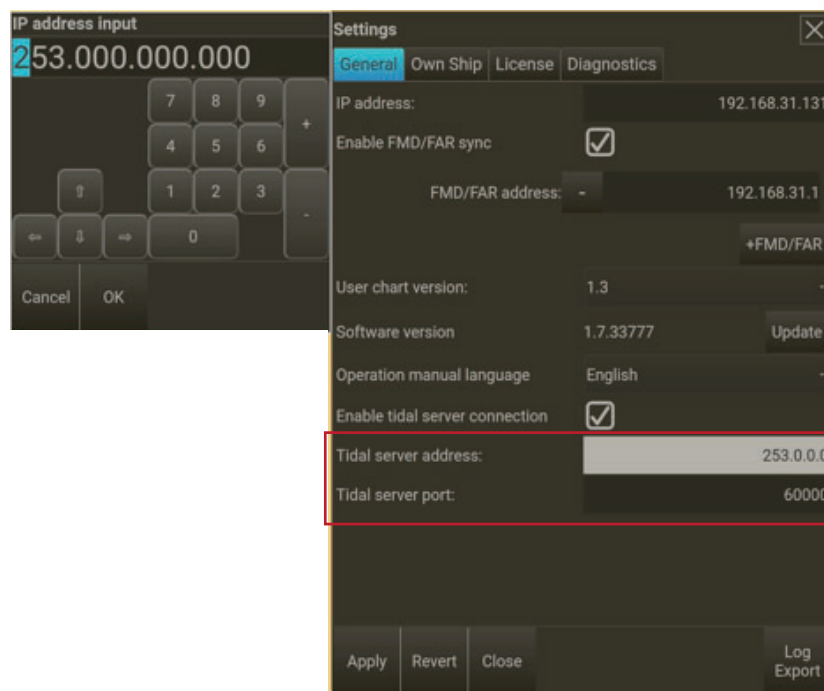

3. Tap the [Tidal server address] field and input IP address.
4. Enter the tidal server port no. in the [Tidal server port] field.
5. Tap the [Apply] button. You are asked to confirm restart.
6. Tap the [Restart] button to restart the system and finish.

**How to view information of tidal station/ tidal stream station**

Tap and hold the tidal station or tidal stream station object symbol on the chart to show the context menu, and then select the [Pick report]. The [Pick report] window with the tidal object information is shown. Tap the attributes field to see the [Tidal Information] window with the tidal graphic, the tidal station/ tidal stream station symbols on the chart, the tidal direction, speed, time, and tidal position values. The tidal direction, speed, time and position values are updated every ten (10) minutes.

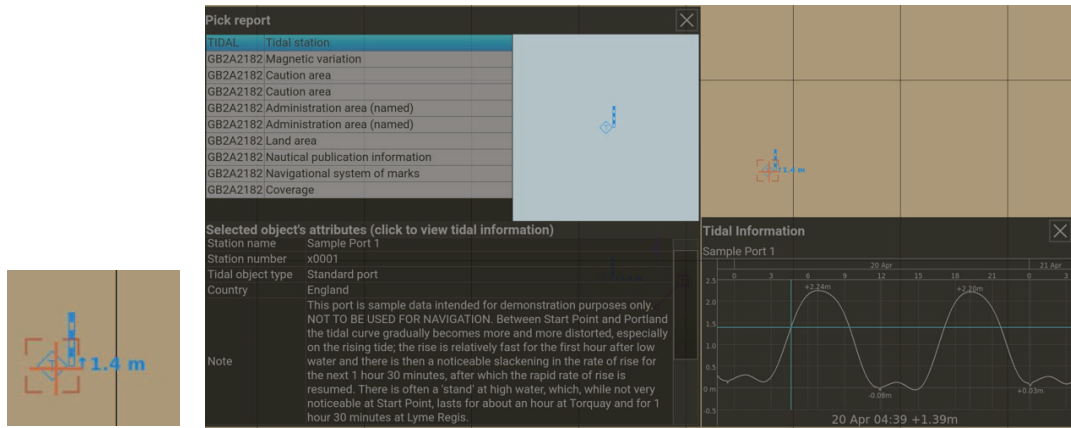

[Tidal station] information window

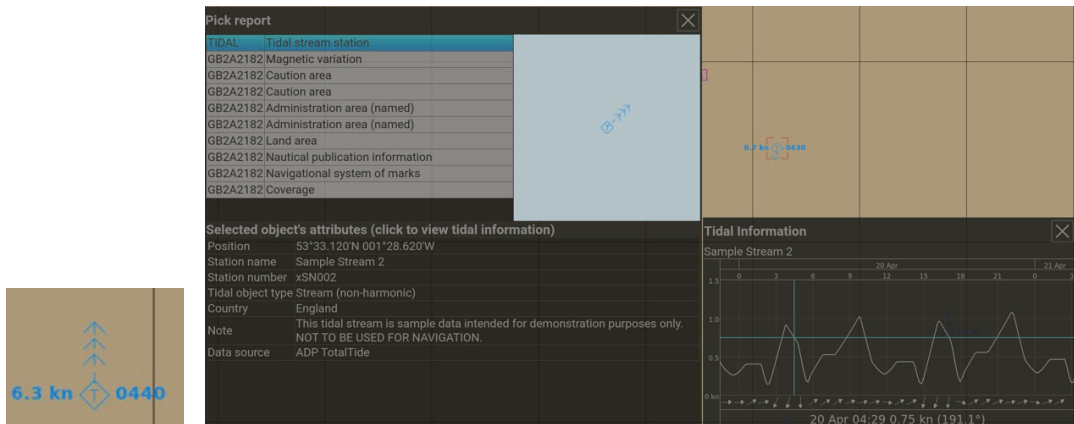

[Tidal stream station] information window

**[Tidal Settings] window**

The tidal information can be received from the ADP server. When this is done, the [Tidal] button appears next to the [Weather] button. Tap the [Tidal] button to show the [Tidal Settings] window, where you can show or hide various tidal information. If no data is received, the [Tidal] button is grayed out.

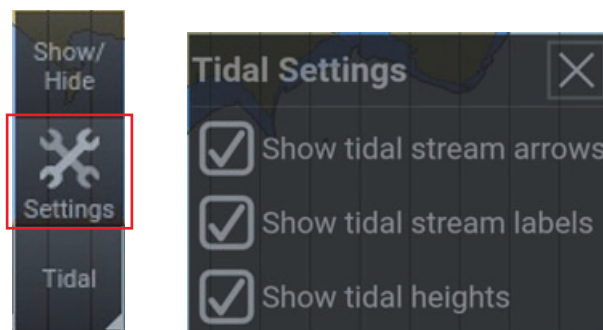

- [Show tidal stream arrows]: Shows the tidal direction with arrow.
- [Show tidal stream labels]: Shows the tidal speed and time.
- [Show tidal heights]: Shows the tidal position.

**Tidal graphic display**

You can change the date and time of the graphic display by dragging the tidal graph horizontally.

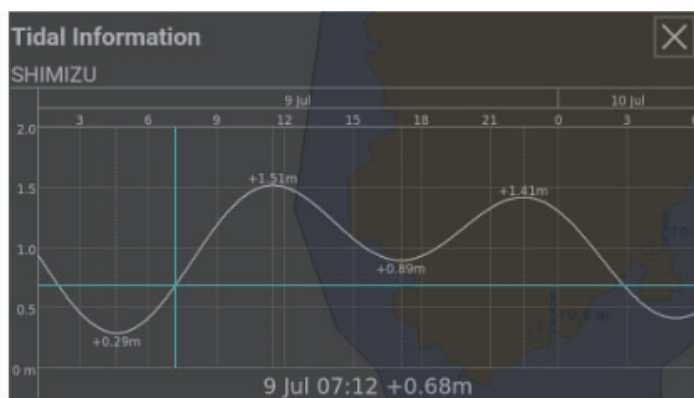

## 8.4 How to Lock/Unlock the Planning Station Display

To avoid unwanted operation of the Planning Station, you can lock the touch screen.

1. Tap the [System] button.
2. Select [Screen Lock] to lock the touch screen. The window shown in the figure below appears.
3. To unlock the touch screen, tap the [Unlock] button.

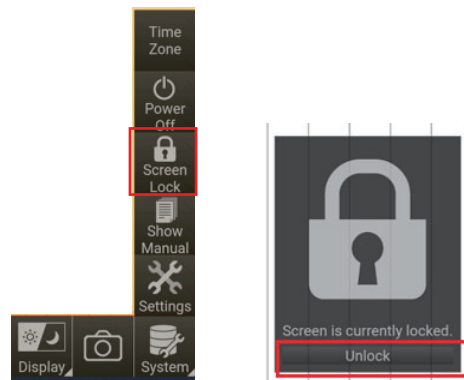

# 9. SYSTEM SETTINGS

---

## 9.1 System Settings

The [Settings] menu provides general settings, diagnostics, own ship settings, offsets for CCRP and antenna position, and license functions. To show the menu, tap the [System] button at the bottom right corner and select [Settings].

**Note 1:** See section 2.1 for information about licenses.

**Note 2:** See section 14.2 for information about diagnostics.

### **[General] tab**

The [General] tab provides the functions listed below.

- [IP address]: Planning Station IP address settings.
- [Enable FMD/FAR sync]: Turn the ECIDS/RADAR synchronization ON/OFF.
- [FMD/FAR address]: The ECDIS/RADAR IP address settings.
- [+FMD/FAR]: Add the ECDIS/RADAR to synchronize.
- [User chart version]: Select user chart version (disabled when userchart is being edited. The message "Close all edited usercharts before changing version" is shown).
- [Software version]: Show the current software version information.
- [Update] button: Tap to update software version.
- [Operation manual language]: Select the language.
- [Enable tidal server connection]: Turn tidal server connection ON/OFF.

**Note 1:** Check the Planning Station IP address when connected to other devices on the network. If connected to the ADP tidal server, confirm its IP address/tidal server port number, and check the box for [Enable tidal server connection] (available in the future).

**Note 2:** Check the connected ECDIS/RADAR IP address(es) and [Select User Chart version] to be sent to the ECDIS/RADAR. To add IP address, tap [+FMD/FAR] button.

- FMD-3xxx IP address: 192.168.31.1, 192.168.31.2, ...
- FAR-3xxx IP address: 192.168.31.31, 192.168.31.32, ...

**Note 3:** The priority goes to the first registered IP address (first line). If the synchronization fails with the first IP address, the next registered IP address is used.

## 9. SYSTEM SETTINGS

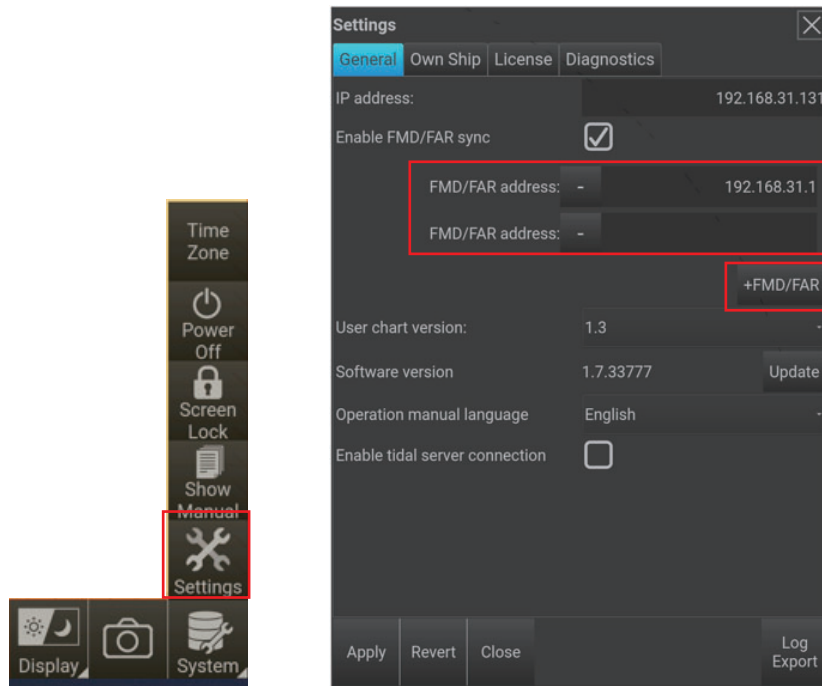

### **[Own ship] tab**

View/edit vessel dimensions of own ship, offset position of Common Consistent Reference Point (CCRP) and antenna positions of connected sensors. CCRP standard position is the center of the stern.

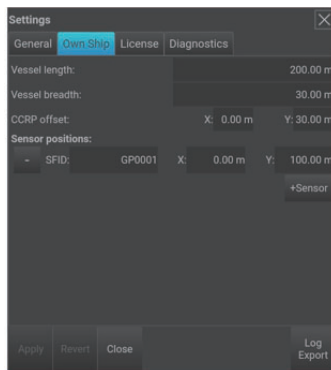

CCRP offset  
X: 0.00 m, Y: 30.00 m

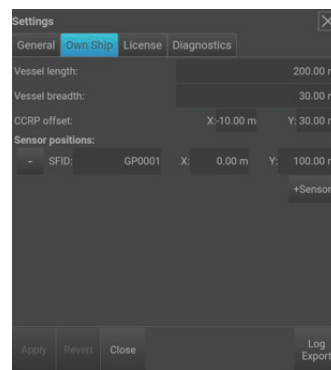

CCRP offset  
X: -10.00 m, Y: 30.00 m



**Note 1:** The information of the [Own ship] tab is automatically synchronized when connected to the ECDIS/RADAR. When the ECDIS/RADAR is not connected to the network, you can modify own ship parameters manually on the [Own ship] tab. Tap the [Apply] button and restart the equipment to save settings.

**Note 2:** When the ECDIS/RADAR is connected to the network, the own ship's information is synchronized from ECDIS/RADAR and editing is disabled. Therefore, the area for setting values will be grayed out and the [-] and [+Sensor] buttons on the left of the SFID are not shown.



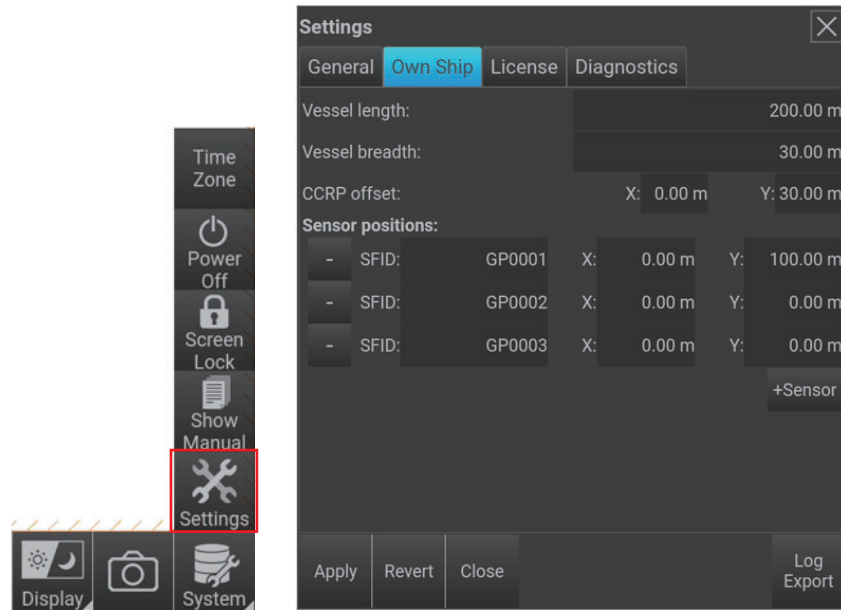

### 9.1.1 Operator's manual language settings

To change the language of the operator's manual, follow the procedure below.

1. Tap the [System] button and select [Settings] to show the [Settings] window.
2. Change the language at [Operation manual language].
3. Tap the [Apply] button to save the settings.

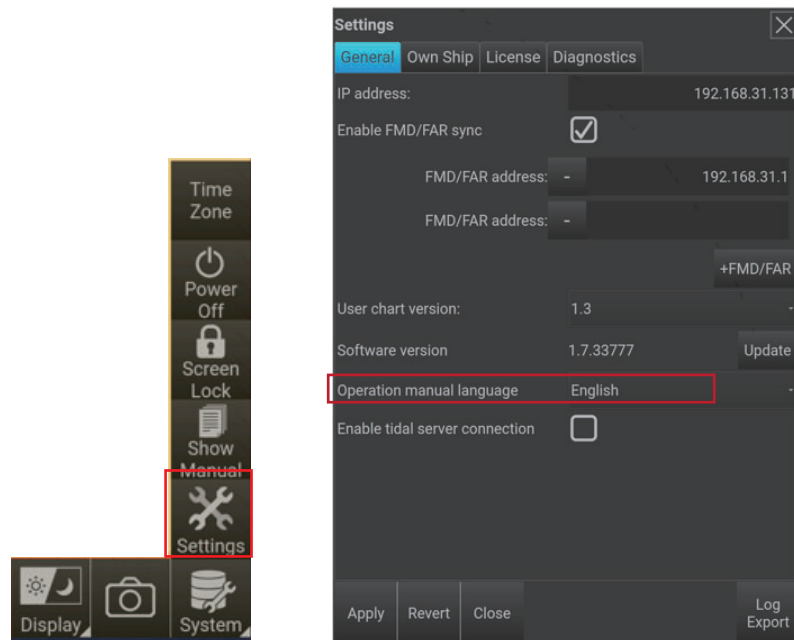

This page is intentionally left blank.

# 10. WEATHER FORECAST

The weather forecast function provides wind, wave, and ocean current information. The content of the information depends on the service provider. Data imported to Planning the Station should be in grib 1 (.grb) format.

## 10.1 How to Import Weather Data

Do as follows to import weather data.

1. Insert the USB flash memory that holds the weather data into the USB port.
2. Tap the [Weather] button and select [Settings] to open the [Weather Overlay] window.
3. Select the [Files] tab to show the file information display.

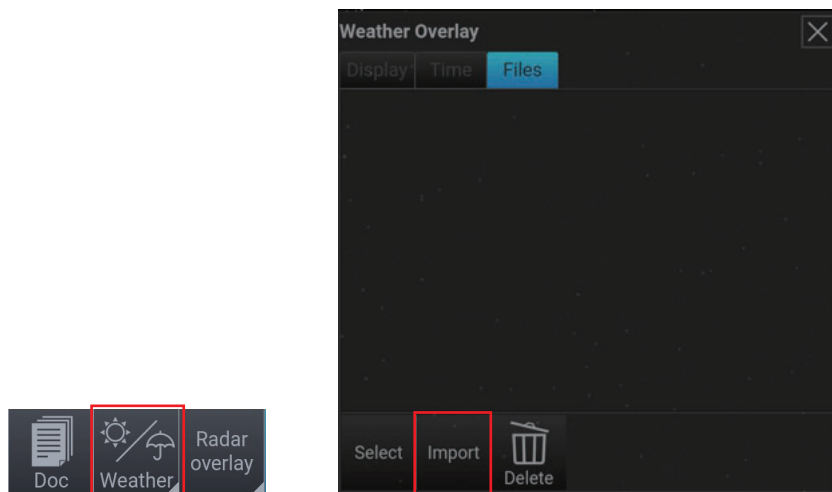

4. Tap the [Import] button to open the [Select files] window.

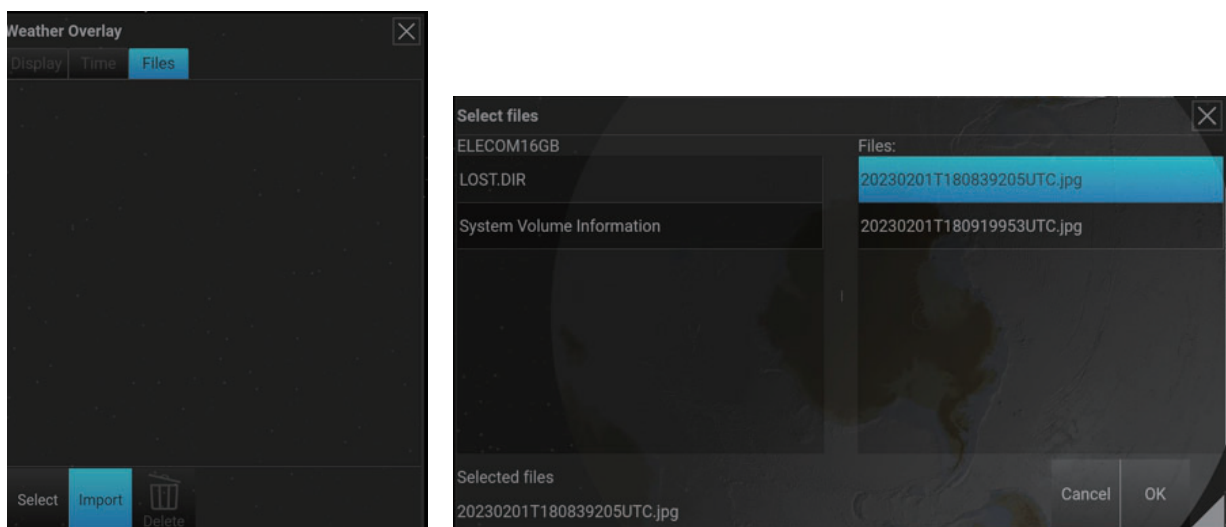

5. Select the file to import and tap the [OK] button to import data and finish.

## 10.2 How to View Weather Data

### 10.2.1 How to select the weather data file to display

1. Tap the [Weather] button and select [Settings] to open the [Weather Overlay] window.
2. Select the [Files] tab to show the file information display.

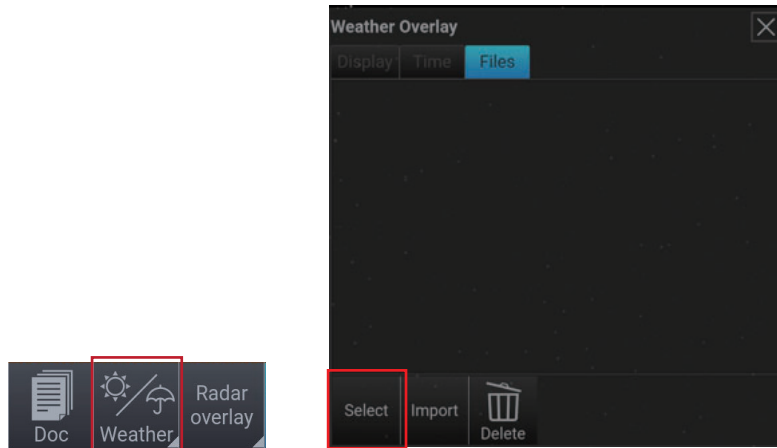

3. Tap the [Select] button to display the [Select weather file] window.

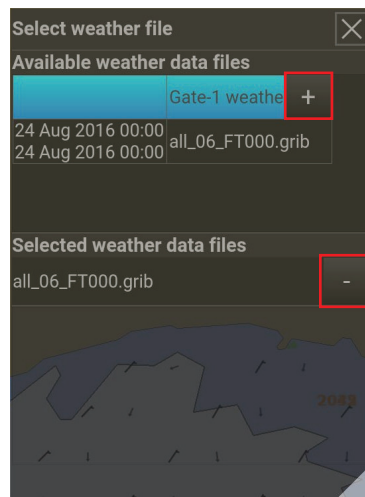

- Select desired file(s) from the [Available weather data files] list. The weather information for the selected file is displayed at the bottom of the [Select weather file] window.

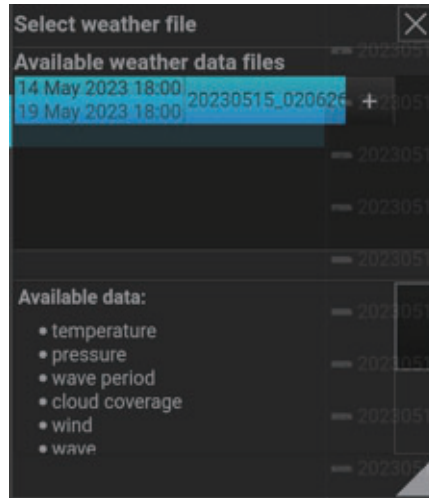

- Tap the [+] button to select the weather data. The detailed information of weather data is displayed on the [Weather Overlay] window.

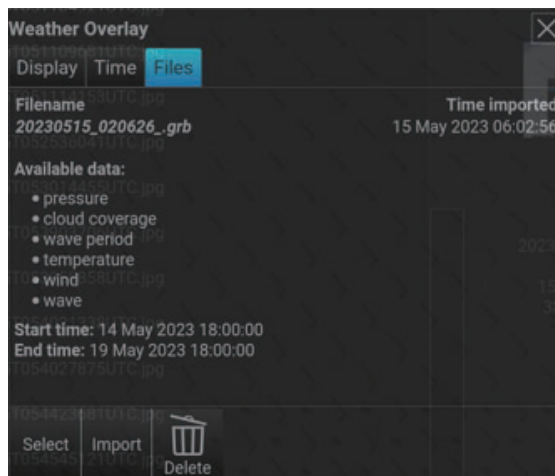

- To remove weather data from the [Selected weather data files] list, tap the [-] button.
- Tap the [x] button to finish.

### 10.2.2 Weather legend

The [Weather legend] provides weather data for the location selected. Tap anywhere on the chart to show the context menu, and select [Weather legend] to show weather data for the area selected. The following weather information is displayed: Temperature (°C), pressure (mbar), cloud coverage (%), precipitation rate (mm/h), wind (m/s), wind direction (°), wave height (m), and wave direction (°) are shown for the location selected.

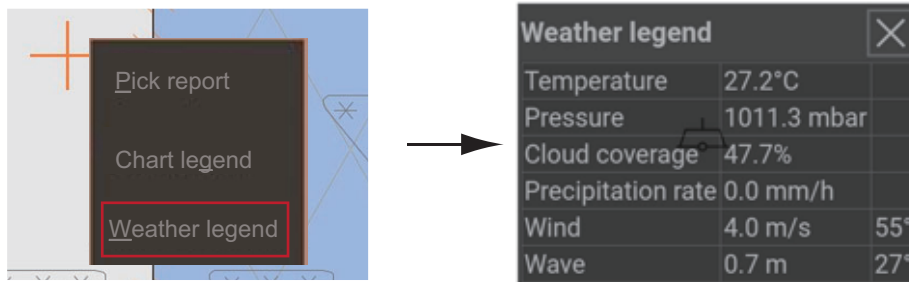

### 10.2.3 Weather data information display

You can show or hide weather information. Tap the [Weather] button and select [Settings] to open the [Weather Overlay] window. Tap the [Display] tab to open the menu shown in the figure on the next page. You can select the information to show or hide with the checkboxes. The weather data file must contain the data selected in order to display it. The color slider adjusts the color presentation for the selected item. The [dense-sparse] slider adjusts the pressure line density. When an active route is displayed, the own ship symbol also moves with playback time. The display range for each item is shown below.

- [Wind]: 1.5 m/s to 38.6 m/s, wind direction: 0° to 360°
- [Temperature]: -40.0°C to 39.4°C
- [Cloud Coverage]: 0.0% to 100.0%
- [Precipitation Rate]: 0.0mm/h to 15.0mm/h
- [Wave] height: 0.1m to 15.0m, wave direction: 0° to 360°
- [Ocean Current]: 0.1m/s to 2.6 m/s, ocean current direction: 0° to 360°

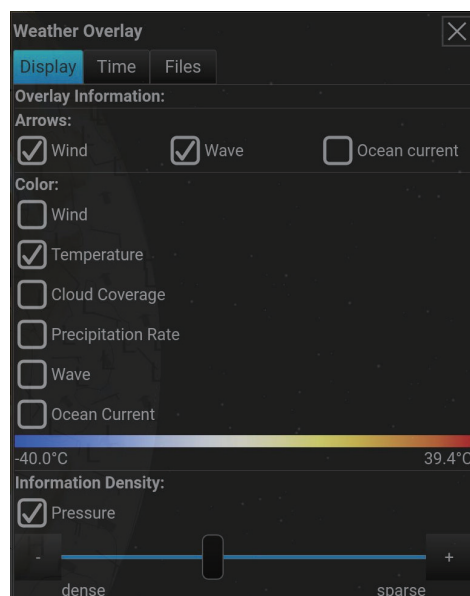

## 10.3 How to Use Weather Data Together With Route Data

If you have weather data for the same area as a planned route, you can get a simulated display of ship movement together with weather data over time. The own ship symbol moves according to the ETD (Estimated Time of Departure) and planned ship speed set when creating the route.

To view your route and weather data at the same time, follow these steps.

**Note:** If a route is edited during weather data playback, the weather data playback is stopped.

1. Tap the [Weather] button and select [Settings] to open the [Weather Overlay] window.
2. Select the [Files] tab to show the file information display.
3. Tap the [Select] button to display the [Select weather file] window.
4. Select desired weather data from the [Available weather data files] list.
5. Tap the [Route] and [Select] buttons to show the [Select Route] window.

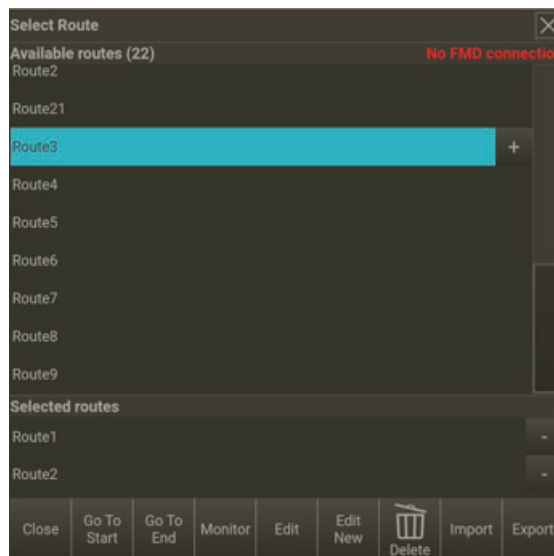

6. Select desired route from the list.

## 10. WEATHER FORECAST

- Open the [Weather overlay] window and tap the [Time] tab.

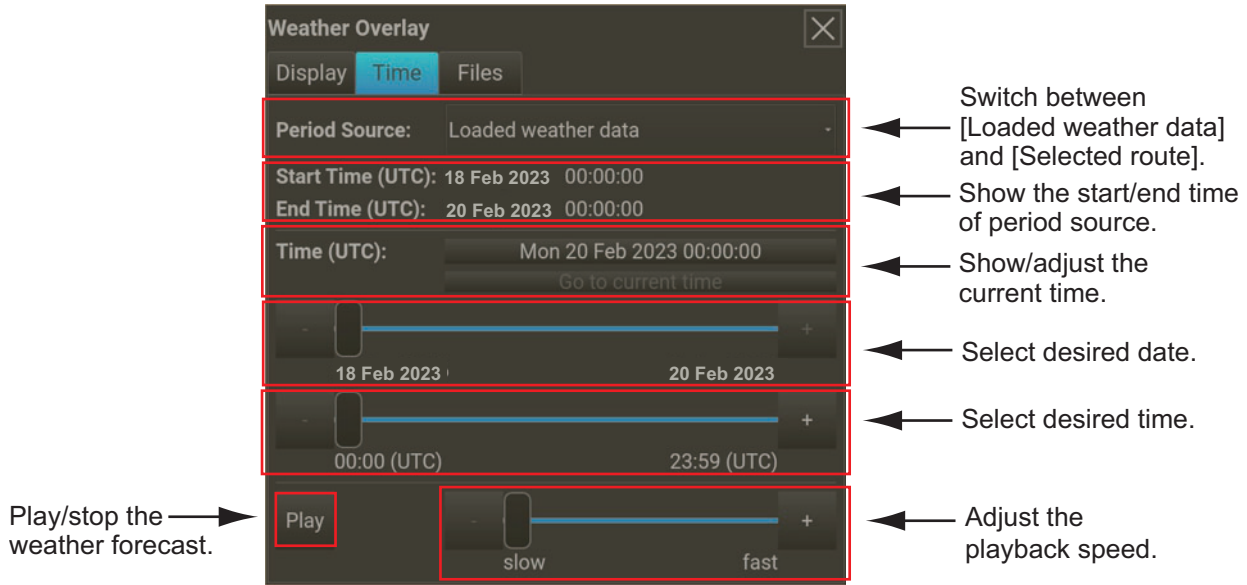

- Use the slider to select desired time and date of the ETD/ETA set for the route selected in step 6.
- Use the [Slow - Fast] slider to adjust speed of animation.
- Tap the [Play] button to get animation of weather forecast together with own ship movement.

**Note 1:** ETD/ETA must be set to select [Selected route] for the [Period Source].

**Note 2:** The [Time (UTC)] displays the date and time currently playing in the set [Period Source]. If the set period source contains the current system time, the [Go to current time] button is enabled. Tap the [Go to current time] button to start playback from the same time as the current system time.

## 10.4 How to Delete Weather Data

You can delete weather data files from the Planning Station as shown below.

- Tap the [Weather] button and select [Settings] to open the [Weather Overlay] window.
- Select the [Files] tab to show the file information display.

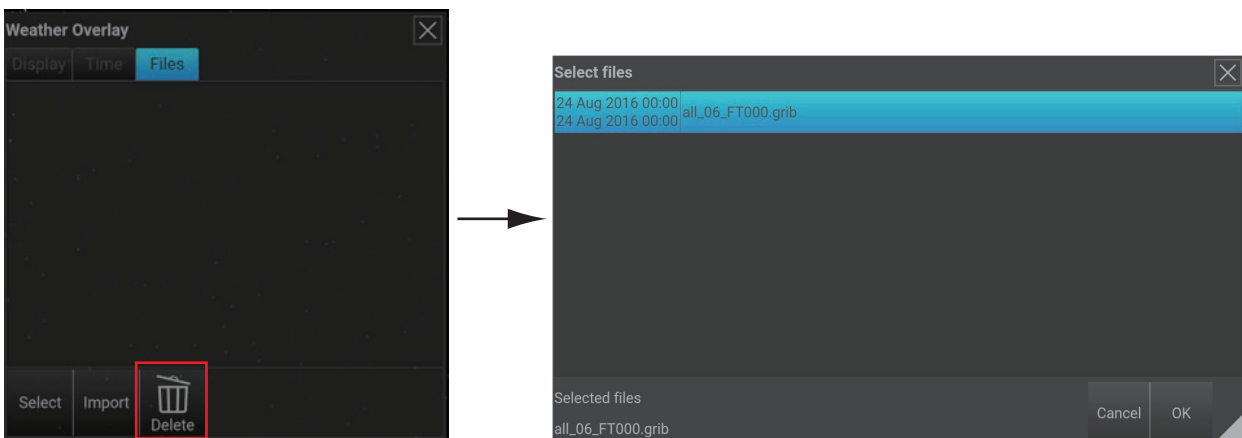

- Tap the [Delete] button.



4. Select the file(s) to delete and tap the [OK] button. You are asked if you are sure to delete the selected file(s).
5. Tap the [OK] button to delete the selected file(s). The [Finished] window appears.

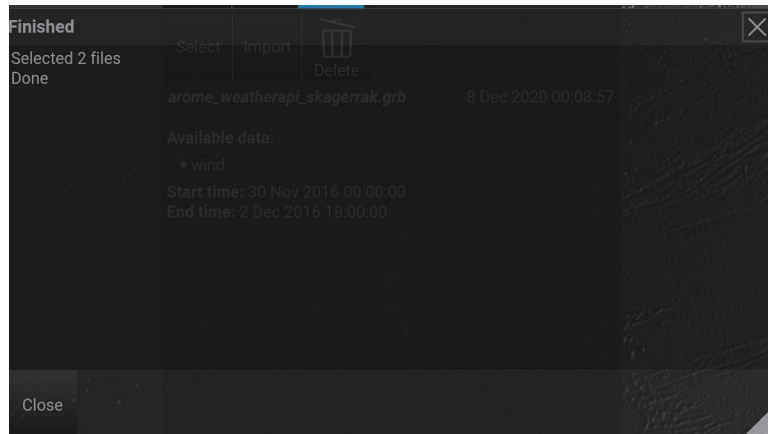

6. Tap the [Close] button to finish.

10. WEATHER FORECAST

This page is intentionally left blank.

# 11. RADAR OVERLAY

## 11.1 How to Activate the Radar Overlay

The radar image is overlaid on the chart display, matching in scale of the displayed chart. Requires ECDIS and radar (FAR-2xx7, FAR-2xx8, FAR-3xxx), connected to HUB-3000.

1. Tap the [Radar Overlay] button.
2. Tap the [Hide/Show] button to show or hide the radar echo on the chart. The [Radar Overlay] button is highlighted in blue when the radar overlay is shown.

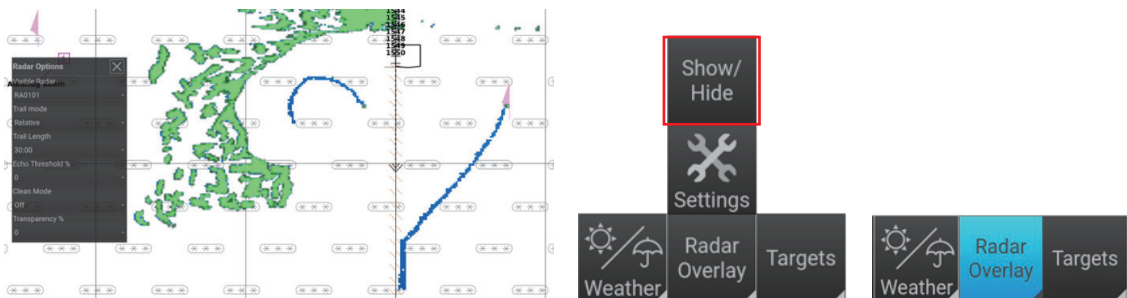

## 11.2 Radar Functions

Do the following to modify the Radar overlay options.

1. Tap the [Radar Overlay] button.
2. Tap the [Settings] button to show the [Radar Options] window. The following radar functions are available.

- [Visible Radar]: Set the radar data source for echoes to be shown from the list.
- [Trail mode]: Set the echo trail mode as [True] or [Relative].
- [Trail Length]: Set the value for trail length (options: Off, 00:15, 00:30, 01:00, 01:30, 02:00, 02:30, 03:00, 04:00, 05:00, 10:00, 20:00, 30:00). When set as [00:30], trails for the last 30 seconds are displayed. When set as [30:00], trails for the last 30 minutes are displayed.
- [Echo Threshold %]: Set the value for echo threshold (options: 0, 10, 20, 30, 40, 50, 60, 70, 80, 90, 100). The higher the value the weaker the gain.
- [Clean Mode]: Select [Off], [Low], [Medium], or [High]. Select [High] for increased noise reduction; low the lesser noise reduction.
- [Transparency %]: Set the degree of echo transparency (options: 0, 10, 20, 30, 40, 50, 60, 70, 80, 90, 100). When the value is set to [0], the radar echoes are displayed overlaid on the chart in the same color as they are. When set to [20], the radar echo will be displayed slightly faded. The higher the value, the fainter the echo display.

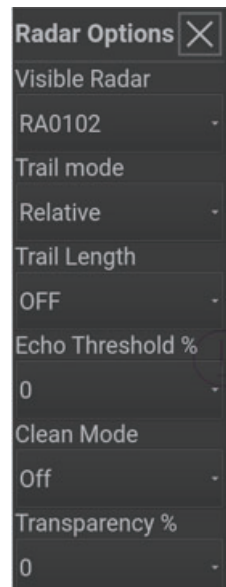

## 11. RADAR OVERLAY

This page is intentionally left blank.

# 12. DOCUMENT VIEWER

The document viewer imports/exports screenshots and documents and provide document editing tools.

## 12.1 How to Import Documents and Screenshots

Do as follows to import documents/screenshots to the Planning Station.

**Note 1:** Compatible document file formats: pdf, jpg, png, bmp, txt.

**Note 2:** Compatible encoding formats for text file: UTF-8, UTF-16, JIS.

1. Insert the USB flash memory with stored document files into the USB port.
2. Tap the [Doc] button to show the [Documents] window.

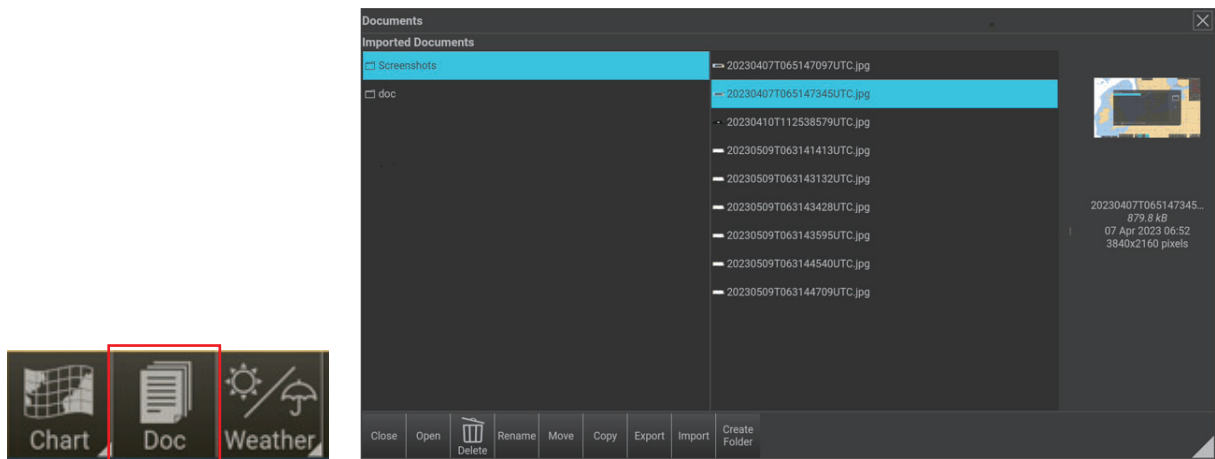

3. Tap the [Import] button to open the window shown in the figure below. A list of the available documents are shown on the window.

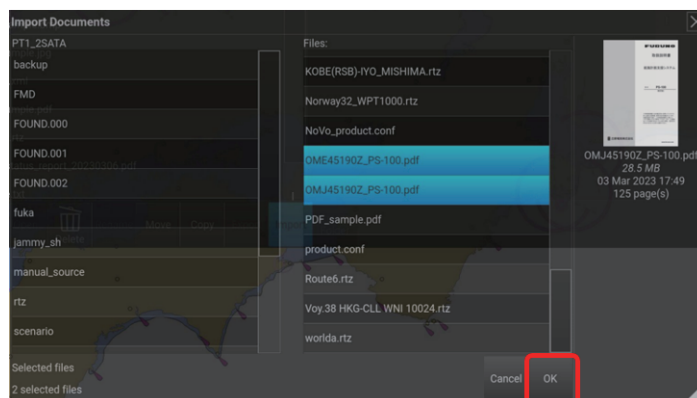

4. Select the file(s) to import and tap the [OK] button.

### 12.1.1 How to view imported documents and screenshots

You can view documents and screenshots on the Planning Station as follows.

1. Tap the [Doc] button to show the [Documents] window.
2. Select a document and tap the [Open] button. Screenshots taken on the Planning Station can be found in the [Screenshots] folder (you can also double tap or tap the displayed image on the right side to view).

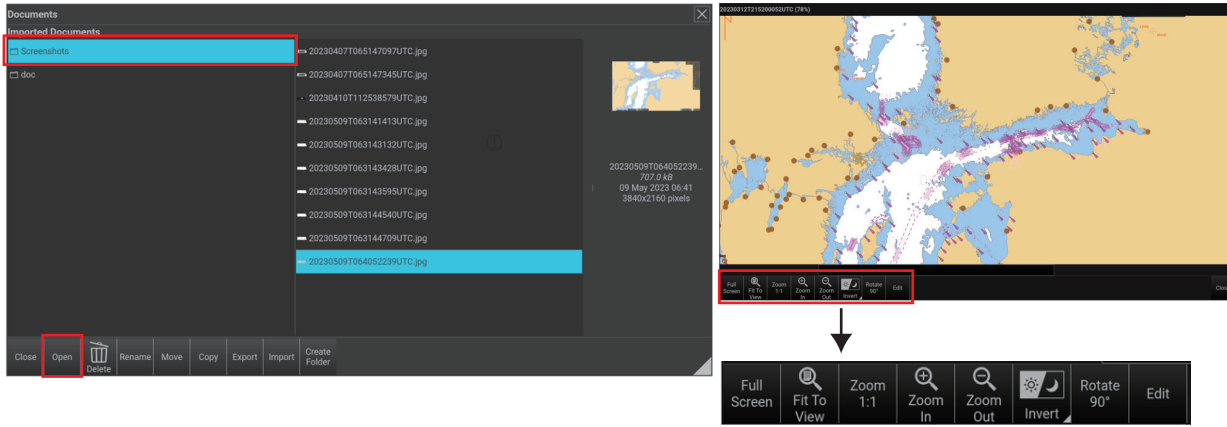

3. If the displayed file has multiple pages, tap the [First Page], [Prev Page], [Next Page], [Last Page] button or the arrows on either side of the page to change the page (from the [Go To Page] window, you can also display the selected page).

Move to the desired page. Tap the thumbnail to switch page.

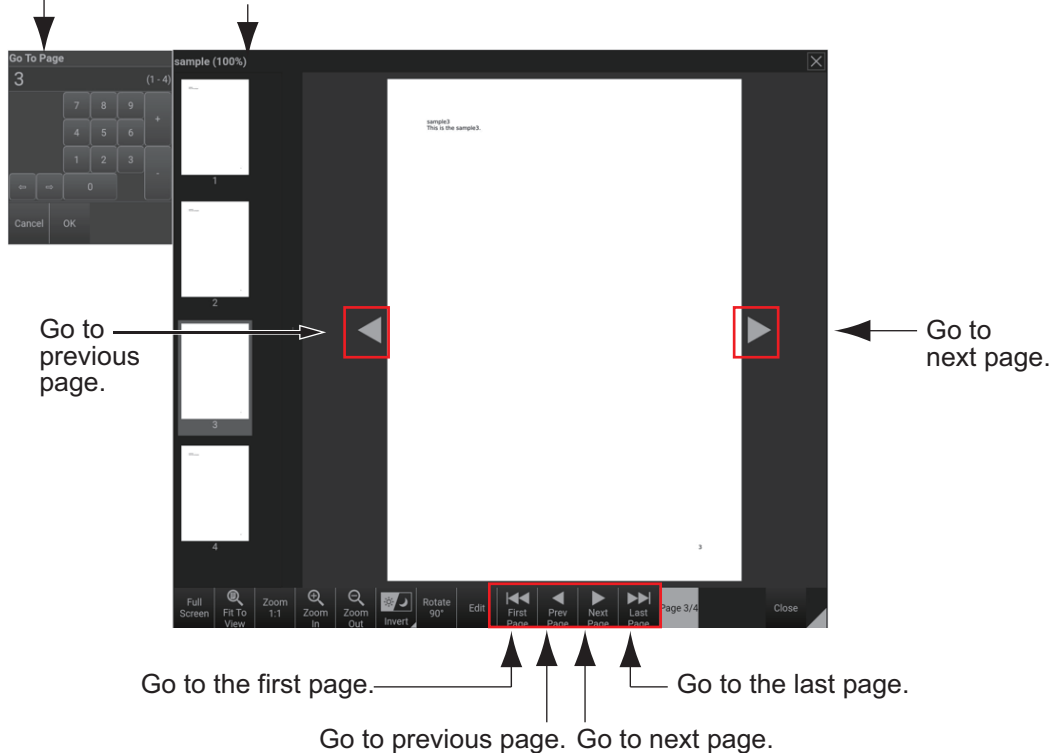

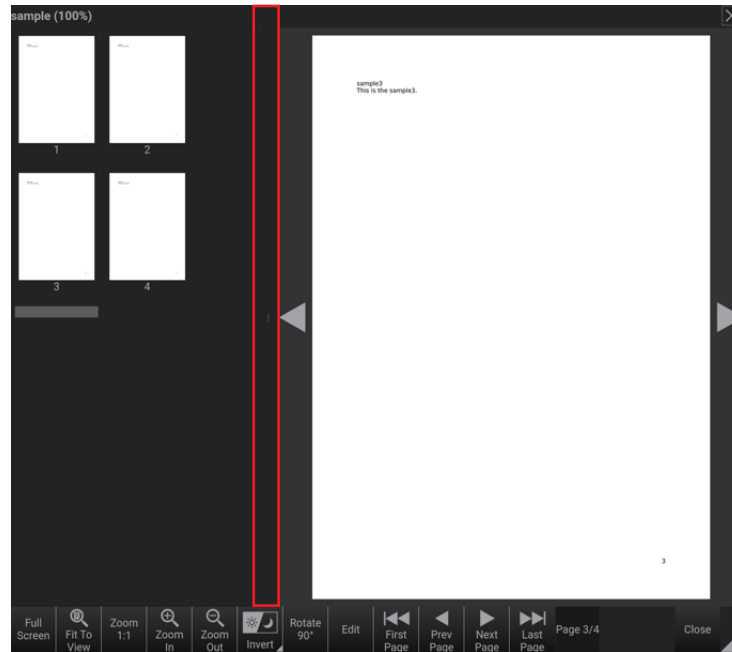

**Note:** By dragging and changing the area in the red frame above, you can change the thumbnail display area and page content display area.

The display of the opened files can be adjusted with the buttons at the bottom of the screen (see section 12.3).

- [Full Screen]: Display the [Document Viewer] window in full screen.
- [Fit to View]: Fit the window to display the document.
- [Zoom 1:1]: The zoom rate is set to 100% regardless of the window size.
- [Zoom in]: The zoom rate is increased (maximum zoom rate: 800%).
- [Zoom out]: The zoom rate is reduced (minimum zoom rate: 6%).
- [Invert]: Inverses the display colors in the display area (Off/Preserve colors/Full).
- [Rotate90°]: Rotate the document 90° clockwise.
- [Edit]: Shows/hides the Toolbox window.

**Note:** You can also take screenshots on the Planning Station. Tap the button shown below to take a screenshot. Screenshots taken on the Planning Station are saved to the [Screenshots] folder.

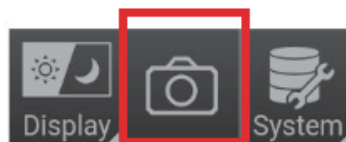

## 12.2 How to Export Documents and Screenshots

Do as follows to export documents and screenshots.

**Note:** Compatible export file formats: pdf, jpg, png, bmp, txt.

1. Connect the USB flash memory to the USB port and tap the [Doc] button to show the [Documents] window.

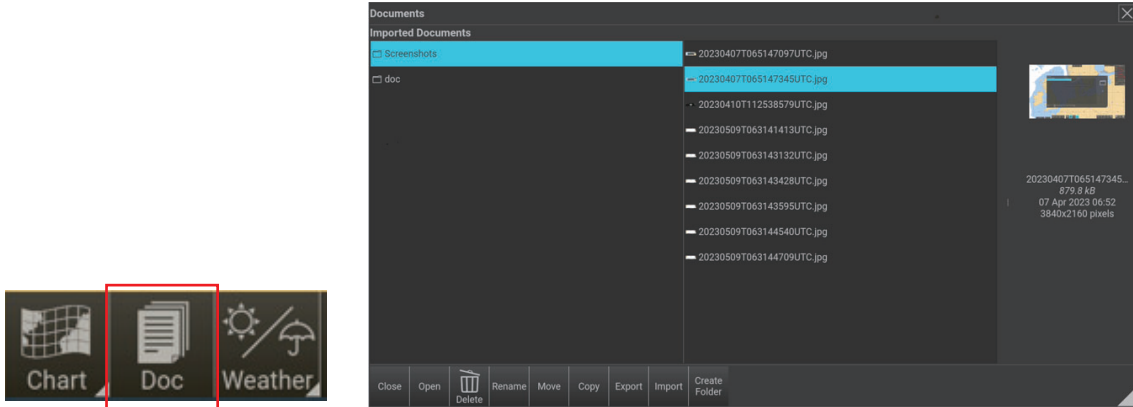

2. Tap the [Export] button and select the files to export.

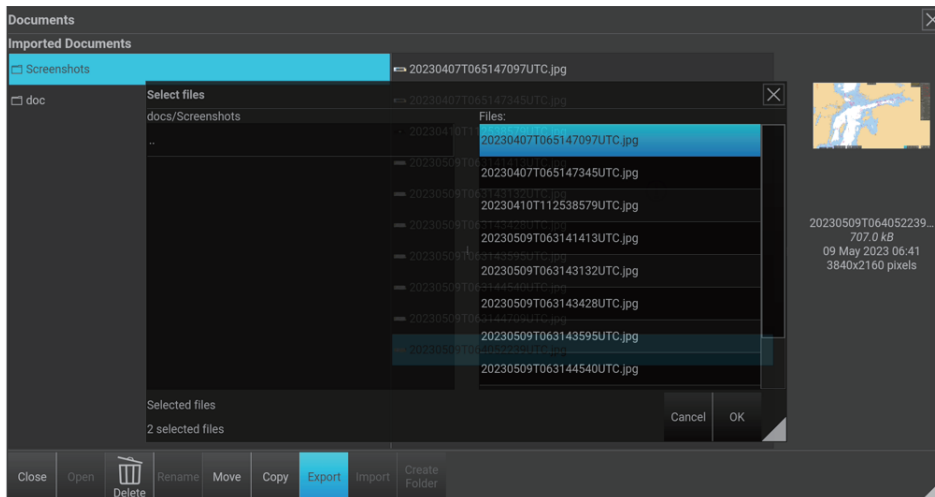

3. Tap the [OK] button to show the [Select target directory] window.

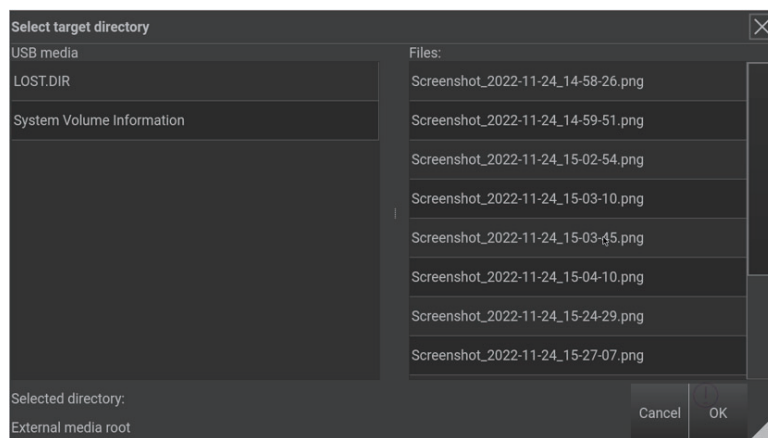

4. Select a directory and tap the [OK] button to export. When the process is completed, the [Finished] window appears.
5. Tap the [Close] to close the window and finish.



## 12.3 How to Edit Documents and Screenshots

You can edit documents and screenshots on the document viewer window (see section 12.1). Open the desired document or screenshot and tap the [Edit] button.

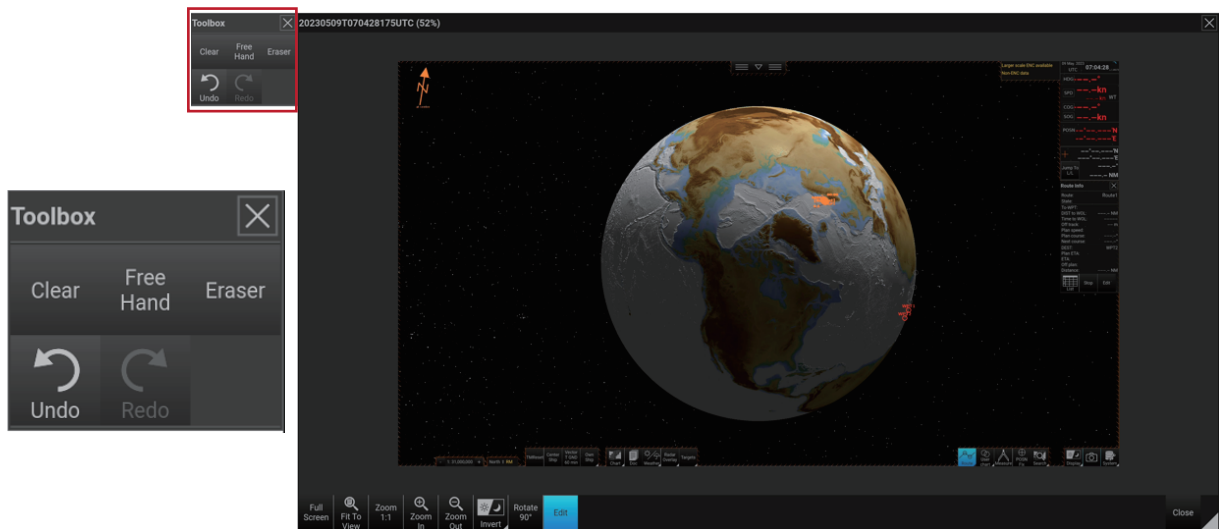

The [Toolbox] window provides the following drawing tools.

- [Clear]: Remove all additional drawings from a document or screenshot.
- [Free hand]: Make a freehand drawing on a document or screenshot.
- [Eraser]: Erase by finger swipe. Width of swipe can be set.
- [Undo]: Undo the previous edit.
- [Redo]: Cancel the [Undo] operation.

**[Free hand] function**

**Note:** Line data edited with free hand function cannot be exported to the USB flash memory.

1. Open the document and tap the [Edit] button at the bottom of the screen to show the [Toolbox] window.
2. Select the [Free hand] button.
3. Drag your index finger over the document to create a drawing.



4. You can also adjust color, opacity and stroke width on the [Options] field in the [Toolbox] display. For changing color, tap the box below [Color] to display the [Stroke color] window. Use the slider or color palette to change the color.
5. By the [+] and [-] button you can save or delete the adjusted color in the color selection of the [Stroke color] window.

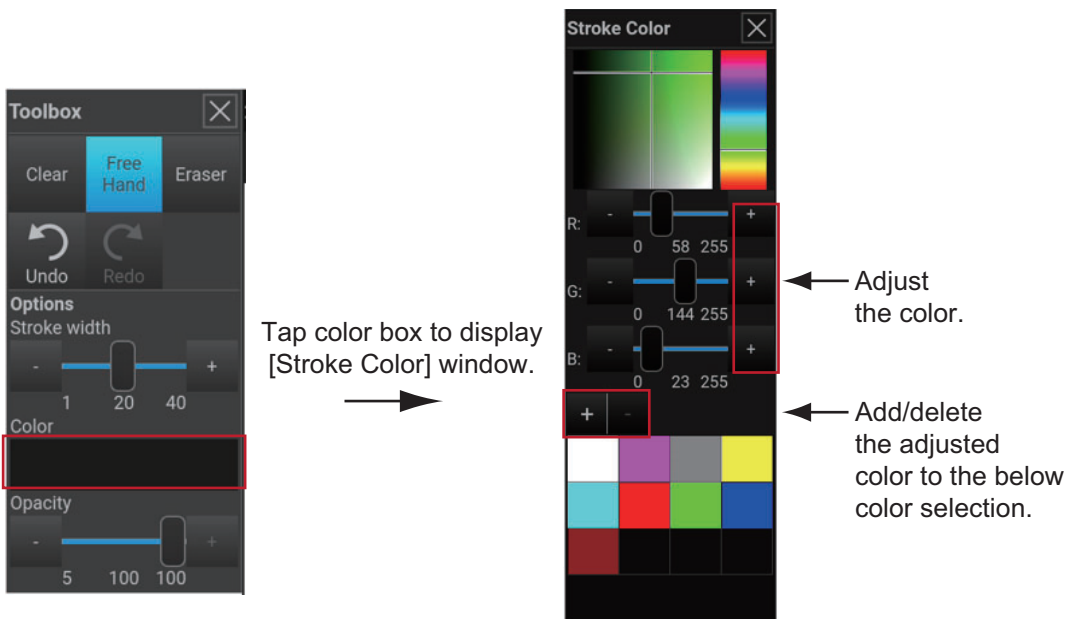

## 12.4 How to Delete Documents and Screenshots

You can delete documents and screenshots which were imported to the Planning Station.

1. Tap the [Doc] button to show the [Documents] window.

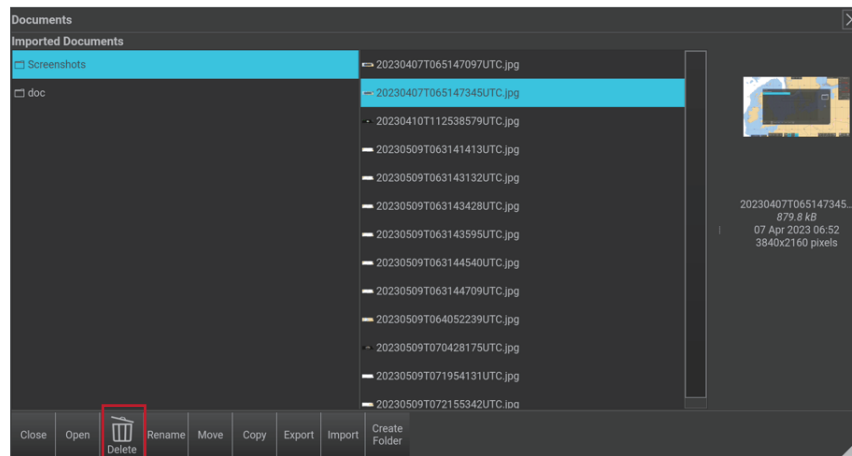

2. Select a document or screenshot and tap the [Delete] button to show the [Delete Documents] window.
3. Select the desired document and tap the [Ok] button.

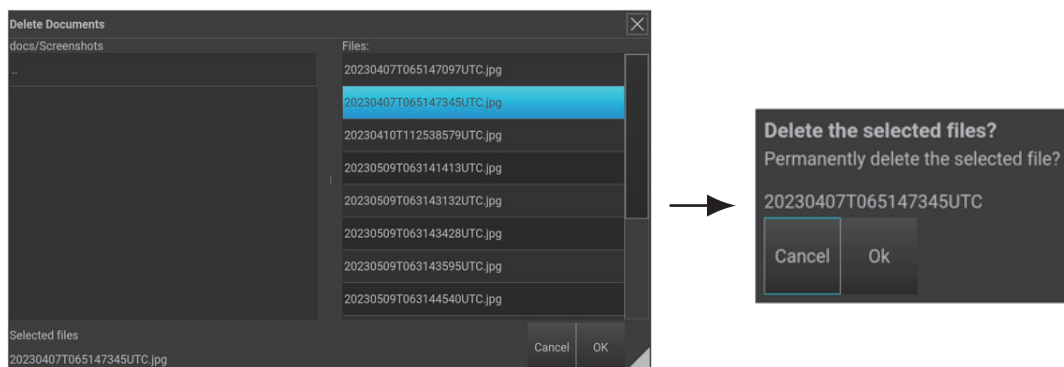

4. The message “Delete selected files?” appears. Tap the [Ok] button to delete.
5. Tap the [Close] button to finish.

**Note:** Folders can also be deleted from the context menu. The [Delete] button cannot be used to delete a folder.

## 12.5 How to Move Documents and Screenshots

You can move documents and screenshots as follows.

1. Tap the [Doc] button to show the [Documents] window.

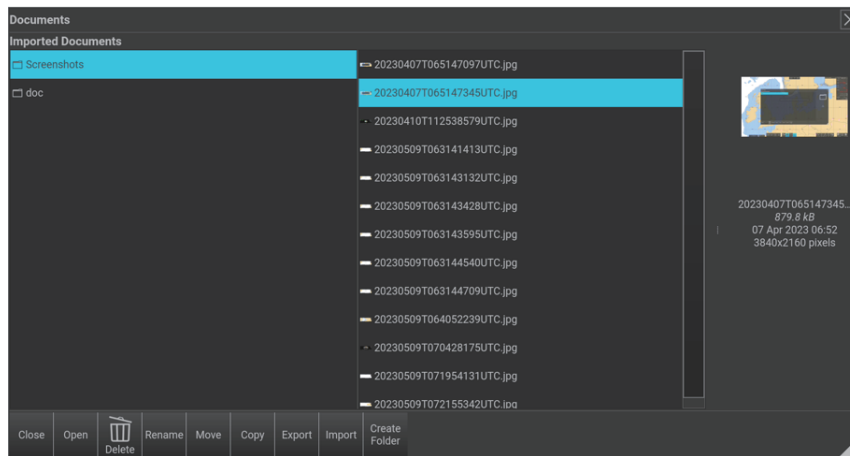

2. Tap the [Move] button to show the [Move Documents] window and select the document or screenshot to move.

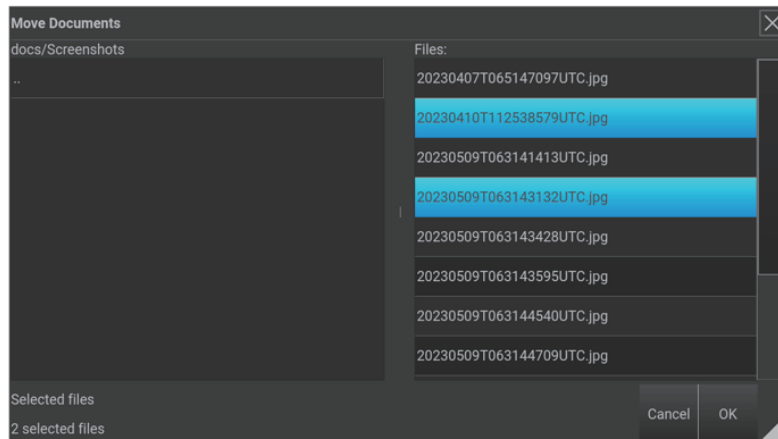

3. Tap the [OK] button.
4. Select a folder for the file and tap the [OK] button.

## 12.6 How to Rename Documents and Screenshots

1. Tap the [Doc] button to show the [Documents] window.
2. Select desired document and tap the [Rename] button to open the window shown below.

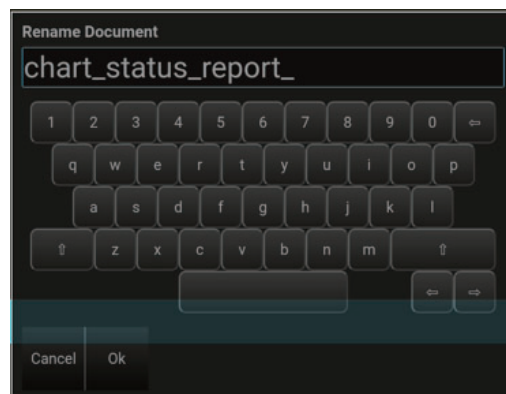

3. Give a name for the document and then tap the [OK] button. The renamed document appears on the [Documents] window.

## 12.7 How to Copy Documents and Screenshots

1. Tap the [Doc] button to show the [Documents] window.
2. Tap the [Copy] button to open the window shown below.

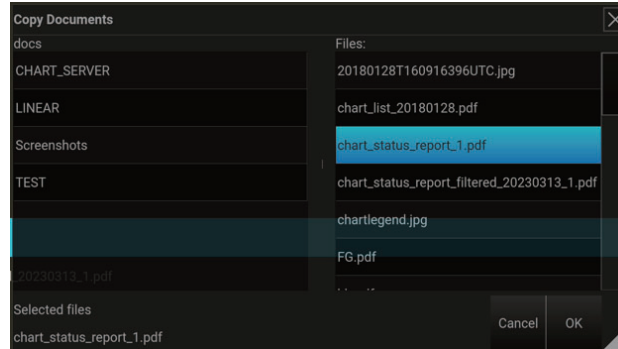

3. Select desired document and then tap the [OK] button. The copied document appears on the [Documents] window as **\*\*\*(copy) file**.

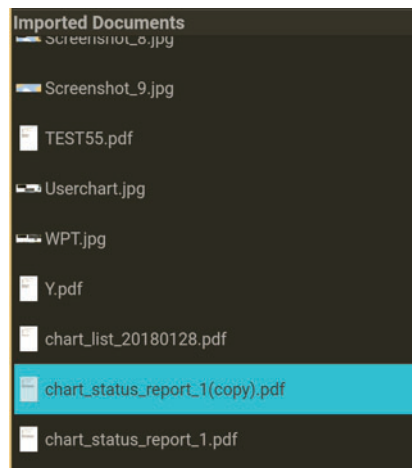

This page is intentionally left blank.

# 13. POSITION FIXING

The position of your ship is determined using the [Position fix] function. Positioning can be done automatically (with the sensors connected to the system), or manually. A label on the chart shows the current position fixing method, as shown in the figure below.



Based on Sensor (GPS)



Manual (EP, LOP) (MAN)

**Note:** The labels show a time stamp and the source of the position fix.

## 13.1 Position Fixing by Sensor

Follow the procedure below to select the sensor to use to fix position.

1. Tap the [POSN Fix] button to display the [Position Fix] window.

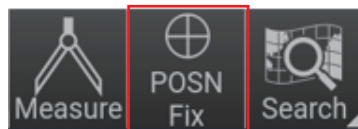

2. Open the [Sensors] tab.



3. Tap the [Store] button to record position of own ship. Current position is received from sensor indicated with [Source].
4. A label and symbol appear on the display to indicate the position of own ship at the time the position was recorded.

## 13.2 How to Fix Position Manually

Position can be fixed manually in three methods: cursor position, Line of Position (LOP), radar echo.

### 13.2.1 Pointing by cursor on chart

Do the following to fix position using cursor position.

1. Tap the [POSN fix] button to show the [Position Fix] window.

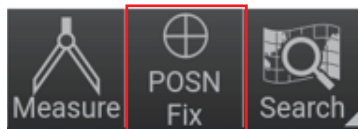

2. Tap the [Manual] tab.

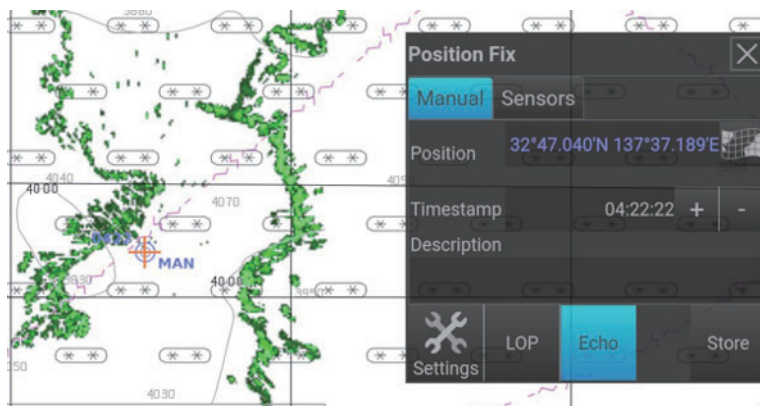

3. On the [Position] field, tap the [  ] symbol.
4. Touch the screen where own ship is located. LAT, LON coordinates appear in the [Position] field. If necessary, you can also modify the values manually.

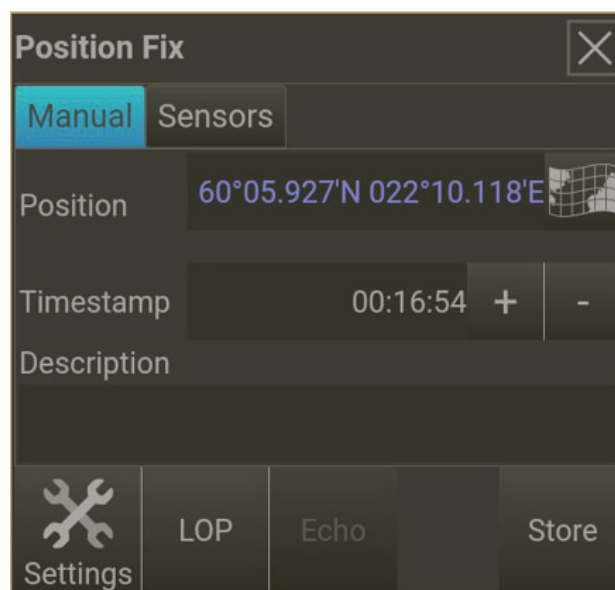

5. If necessary, adjust the timestamp. At [Timestamp], adjust the date/ time by the [+] and [-] buttons.



6. You can provide a description of the position fixing method in the [Description] cell.
7. Tap the [Store] button to record position. The window shown below appears and a label (EP, MAN) appears on the chart.



- Tap [Close] to close the window without further action.
- Tap [Start DR] to start positioning based on Dead Reckoning.
- Tap [Set POSN ADJ] to apply an offset to the position (see section 13.4).

### 13.2.2 Using Line of Position (LOP)

Use of LOP requires at least two observation points (bearing and/or range) to define position of own ship.

1. Tap the [POSN fix] button to show the [Position Fix] window.
2. Tap the [Manual] tab.

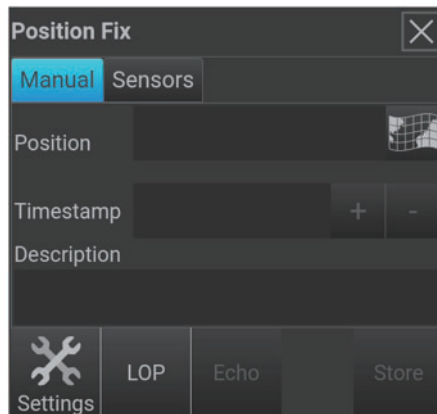

3. Tap the [LOP] button to show the [Line of Position] window and then tap the [+Observation] button.

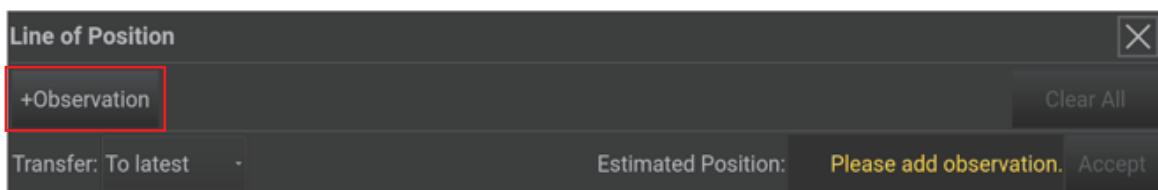

### 13. POSITION FIXING

4. Tap the [  ] icon to point to an object on the chart and select the chart object use to for ship's position.

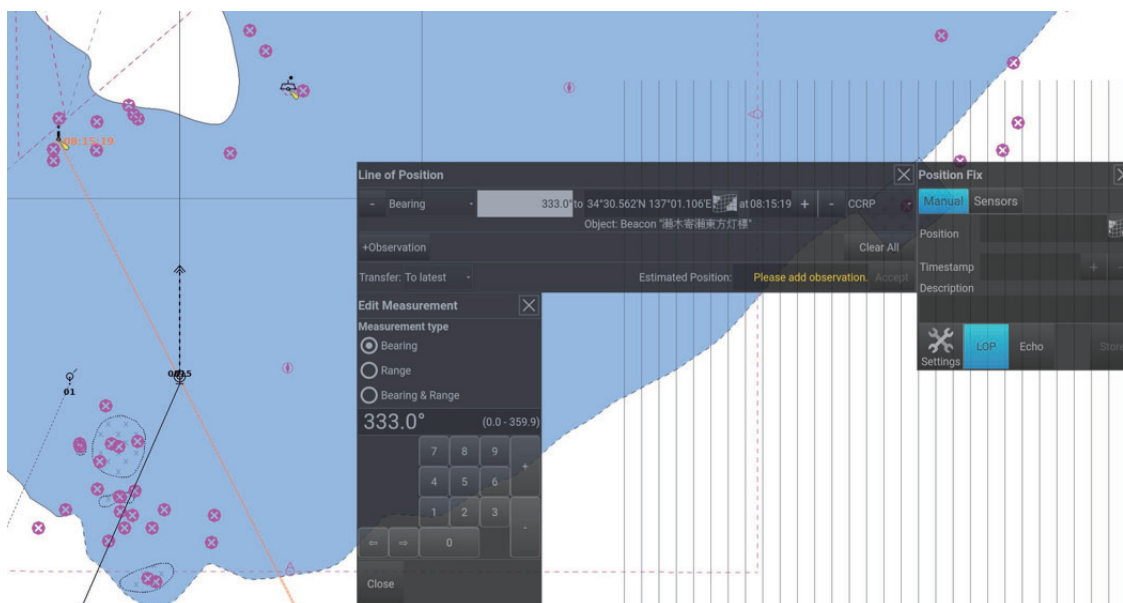

5. Tap [+] or [-] to adjust the time stamp and enter the bearing/range to the object.
6. Repeat steps 3 to 5 to enter all the range/bearing measurements. At least three measurements are recommended in order to get a reliable fixing.

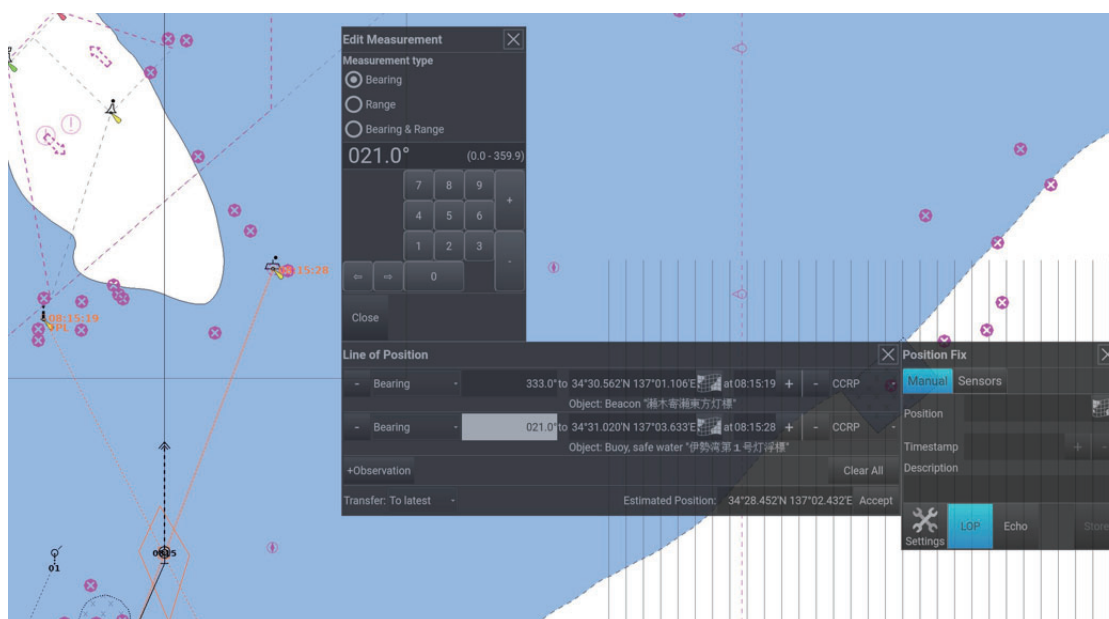

7. From [Transfer] you can select and specify how to display and calculate the time for the estimated position. The options are as follows.
  - [Disabled]: The estimated position is not displayed on the chart and [Estimated Position] column is shown as blank.
  - [To latest]: The estimated position is displayed on the chart based on the time of the calculation. The result is shown in the [Estimated Position] column based on the time of the most recently added observation point.
  - [Continuous]: The estimated position is displayed on the chart based on the ship's position movements. The result is shown in the [Estimated Position] column based on the time of the most recently added observation point.

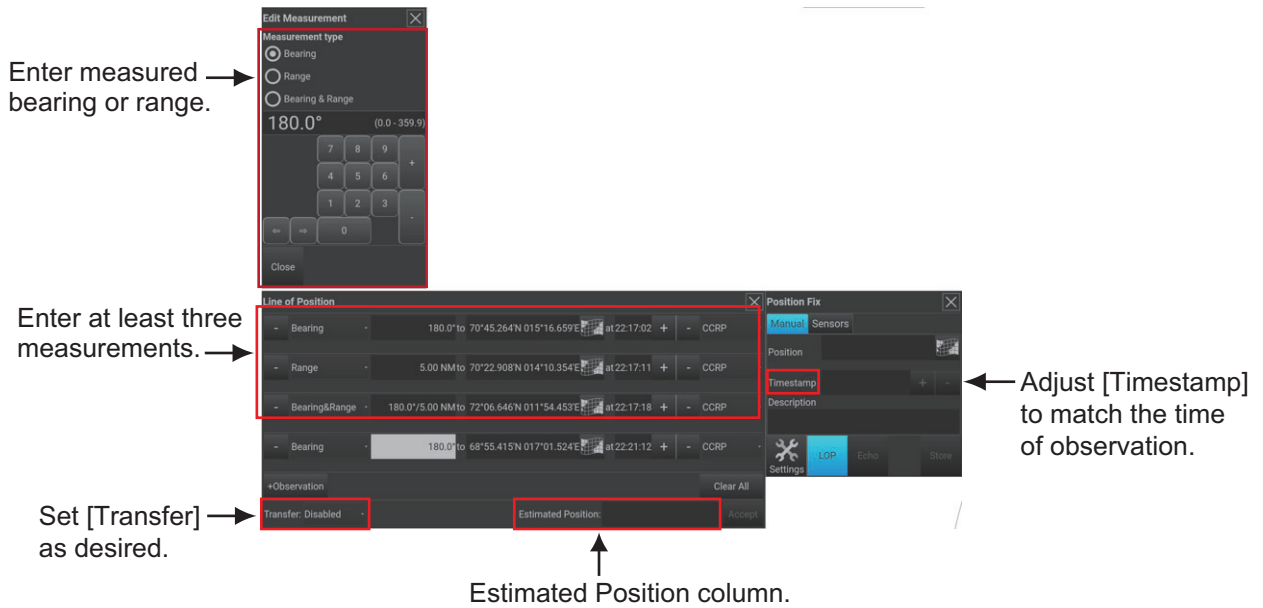

8. An estimated position fixing is calculated based on the added observations and is displayed on the chart. If necessary, you can fine tune the position by moving it on the chart.

**Note:** You can also make a manual position fix while the LOP tool is active. For example, you could use a single LOP measurement together with radar echo to make a manual position fixing.

9. Tap the [Accept] button on the [Line of Position] window. The estimated position is shown on the [Position Fix] window.



**Note:** The [Accept] button is disabled when [Transfer] is set as [Disabled] or when the position cannot be estimated.

10. Select [Store] to record the position. The windows shown in the figure below appears.



- Tap [Close] to close the window without further action.
- Tap [Start DR] to start positioning based on Dead Reckoning.

### 13. POSITION FIXING

- Tap [Set POSN ADJ] to apply an offset to the position (see section 13.4).

The line of position set above can be used as the standard position instead of CCRP. Follow the steps below to add [LOP Locations].

**Note:** See section 9.1 for more information about CCRP.

1. Tap the [POSN fix] button to show the [Position Fix] window.
2. Tap [Settings] to show the [Event Settings] window.
3. Tap the [LOP Locations] tab and then tap the [Add] button.

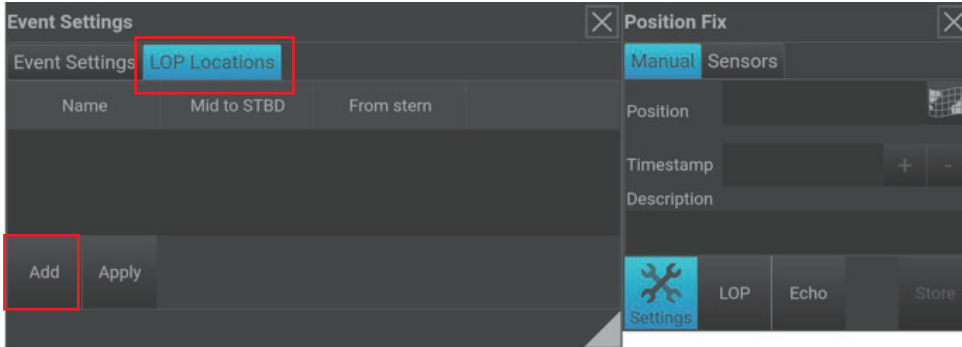

4. Set [Name], [Mid to STBD] and [From stern].

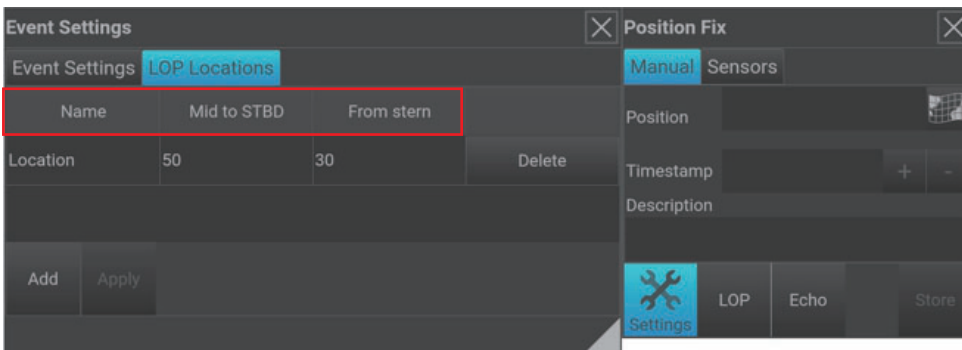

5. Tap the [Apply] button.

### 13.2.3 Using radar echo

If the radar overlay is available, it can be used for positioning. The center of the radar echoes are usually drawn relative to own ship position. If a radar echo is not overlaid on the chart at its correct geographical position, it can be moved to correct for positioning error.

1. Tap the [POSN fix] button to show the [Position Fix] window.
2. Tap the [Manual] tab and then tap the [Echo] button to show the radar echo.

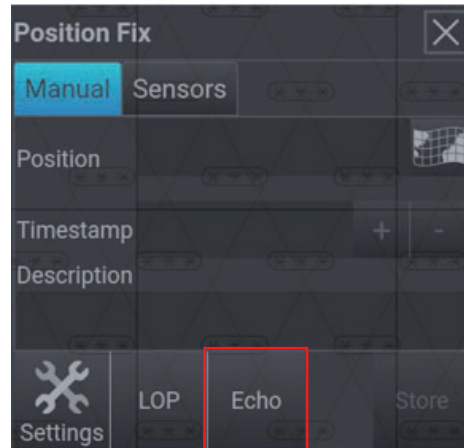

3. Drag the radar overlay echo and adjust the position on the chart to match with the chart object.

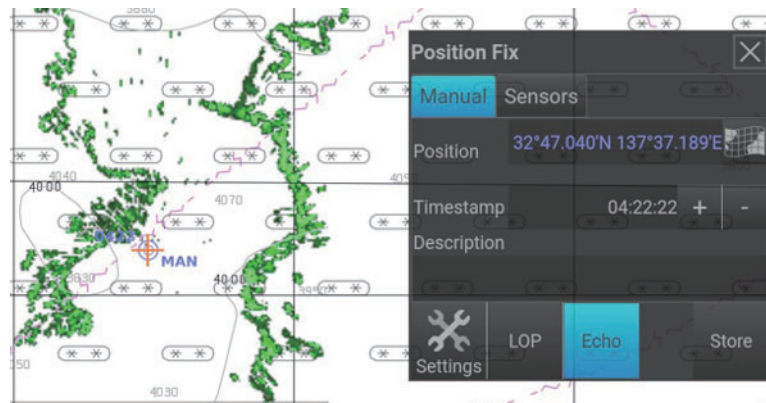

4. Tap the [Store] button. The window shown in the figure below appears.

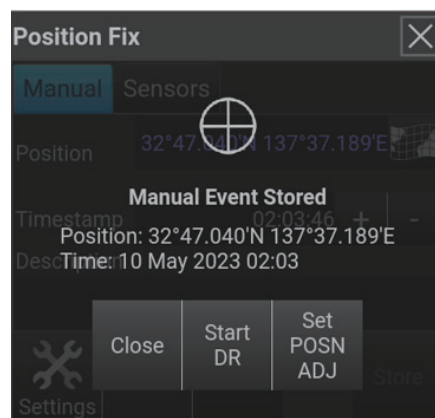

5. Tap the [Set POSN ADJ] button to move the ship's position to the adjusted position.

### 13.3 Label Display Settings

Tap the [POSN Fix] button and then tap the [Settings] button to show the [Event Settings] window. You can adjust the label display settings.

- [Display mode] - [Display inactive and active]: Display both inactive and active labels.
- [Display mode] - [Display active only]: Display the labels set as [Active] only.
- [Max age to display]: the period to display the label (options: None, 1 hour, 12 hours, 24 hours, 1 week, 2 weeks, 3 weeks, 30 days, 60 days, 90 days (default: 90 days)).

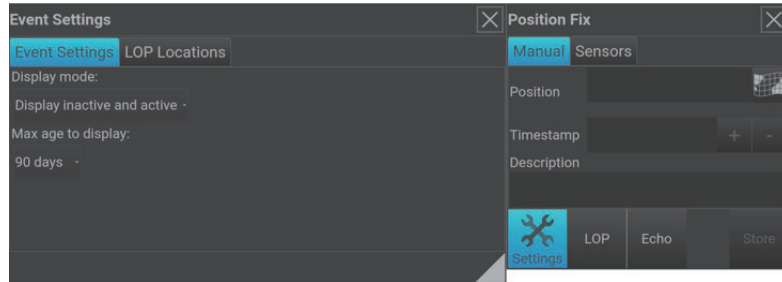

1. Tap and hold the label.
2. Tap the [Event info] in the displayed context menu.
3. The [User event] window appears. Tap the [Active] / [Inactive] cell as appropriate.

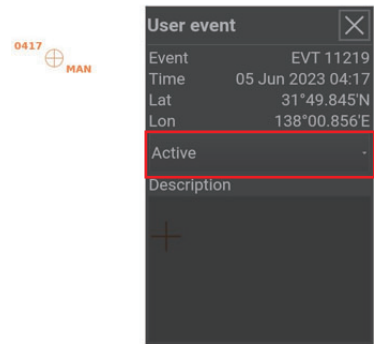

### 13.4 Position Offset

In some cases, it may be necessary to offset position manually when it appears to be incorrect. For how to offset position, see section 13.2.

When position is offset, the text "ADJ" appears together with the offset range and bearing values as shown in the figure at right. To remove position offset, tap the [POSN] button and select [Reset ADJ].

**Note:** If [Use FMD] is selected as a data source on the [Sensor sources] menu (see subsection 2.4.1), [Start DR] is disabled and positioning based on Dead Reckoning cannot not be done.

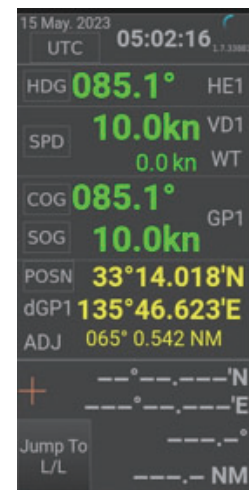

# 14. MAINTENANCE AND TROUBLESHOOTING

## 14.1 Troubleshooting

The troubleshooting table below provides common faults and the remedies with which to restore normal operation.

Problem	Possible cause	Remedy
Power cannot be turned on.	<ul style="list-style-type: none"> <li>Power connector may have loosened.</li> <li>Power supply is off.</li> </ul>	<ul style="list-style-type: none"> <li>Check connector.</li> <li>Check power supply.</li> </ul>
Power can be turned on but nothing appears on the display.	<ul style="list-style-type: none"> <li>Brilliance is too low.</li> <li>Display cable is loosened.</li> </ul>	<ul style="list-style-type: none"> <li>Adjust brilliance.</li> <li>Check display cable connection.</li> <li>Restart the system.</li> </ul>
The picture freezes (display is not updated).	Planning Station internal error.	Press the power switch until the power goes off. Turn the power on again to restore normal operation.
The touch monitor display does not respond even when tapped.	USB cable may have loosened.	Check the cable connection.
Position cannot be found.	<ul style="list-style-type: none"> <li>ECDIS/RADAR power is turned off.</li> <li>Position sensor is not selected.</li> <li>Position sensor is turned off.</li> <li>Sensor connection cable has loosened.</li> </ul>	<ul style="list-style-type: none"> <li>Turn on the ECDIS/RADAR</li> <li>Check position sensor selections.</li> <li>Turn on position sensor.</li> <li>Check the cable connection.</li> </ul>
The message "License file not found or license expired!" appears.	<ul style="list-style-type: none"> <li>The license has expired.</li> <li>USB dongle and license file do not match.</li> </ul>	Contact your local FURUNO dealer. See also section 2.1 for more information.
Displayed routes and user charts disappear from the screen.	GUI (Graphical User Interface) error occurred and was reset.	Contact your local FURUNO dealer.
Routes and user charts cannot be edited or saved on the Planning Station.	<ul style="list-style-type: none"> <li>Routes/user charts are being used on the connected ECDIS/RADAR side.</li> <li>Instant track is being stored on ECDIS/RADAR.</li> </ul>	<ul style="list-style-type: none"> <li>Check the settings on ECDIS/RADAR side.</li> <li>Delete the saved route on ECDIS/RADAR.</li> </ul>

**Note:** Check that all cabling is firmly connected and not damaged (3 to 6 months).

## 14.2 Diagnostics

### 14.2.1 NMEA data export

1. Tap the [System] button and select [Settings] to show the [Settings] menu.
2. Select the [Diagnostics] tab to display the [NMEA Record] window, an example of which is shown in the figure below. The Planning Station displays and records NMEA sentences received from the network. The data can also be exported to a USB flash memory (output format: NND or DAT).

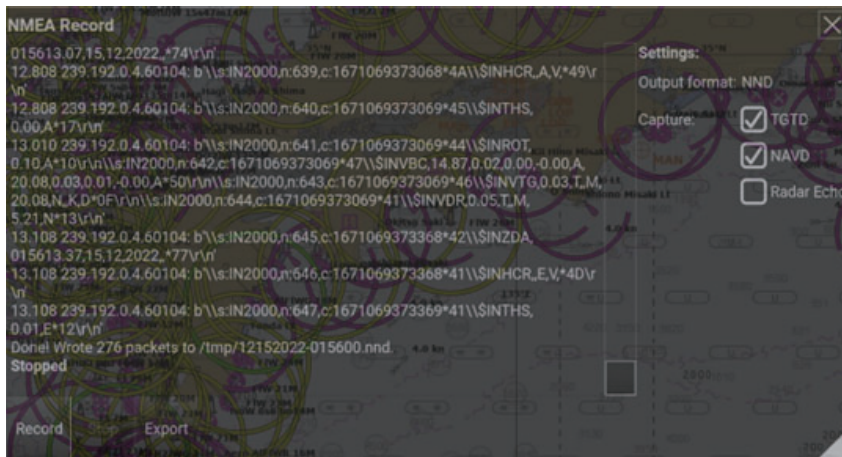

3. Use the checkboxes to select the desired NMEA data to receive and record.
  - TGTD (AIS/TT data): 60002/60102/50000 ports
  - NAVD (GPS sensor data): 60004/60104/50000 ports
  - Radar Echo (echo data): 10024/50000 ports

**Note:** If the output format is set as DAT, radar echo is not received.
4. Tap the [Record] button to record. To stop recording, tap the [Stop] button.
5. To export the NMEA data, insert a USB flash memory to the USB port and do steps 1 to 3.
6. Tap the [Export] button to show the [Select target directory] window.

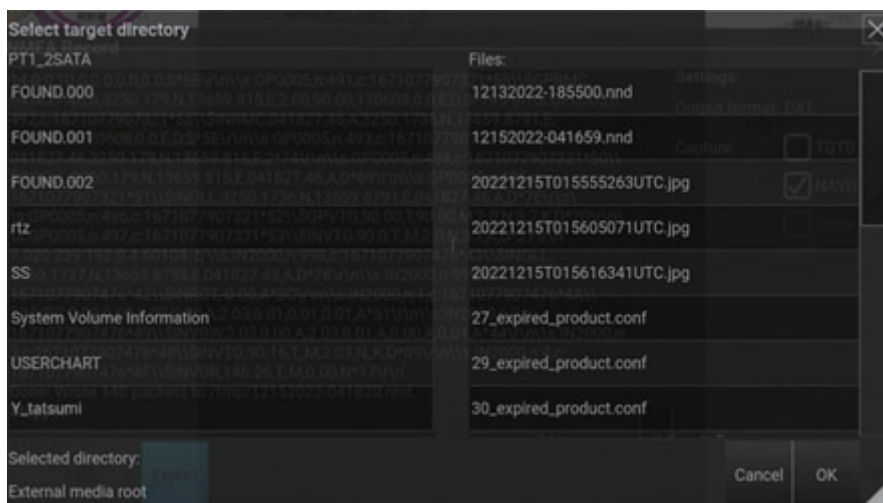

7. Select the folder where to export the data and tap the [OK] button.
8. The [Finished] window appears with exported results. Tap the [Close] button to finish.



## 14.2.2 System log export

Follow the procedure below to export the system log to a USB flash memory.

1. Insert the external USB flash memory into the USB port.
2. Tap the [System] button and select [Settings].
3. Select the [General] tab. The window shown in the figure below appears.

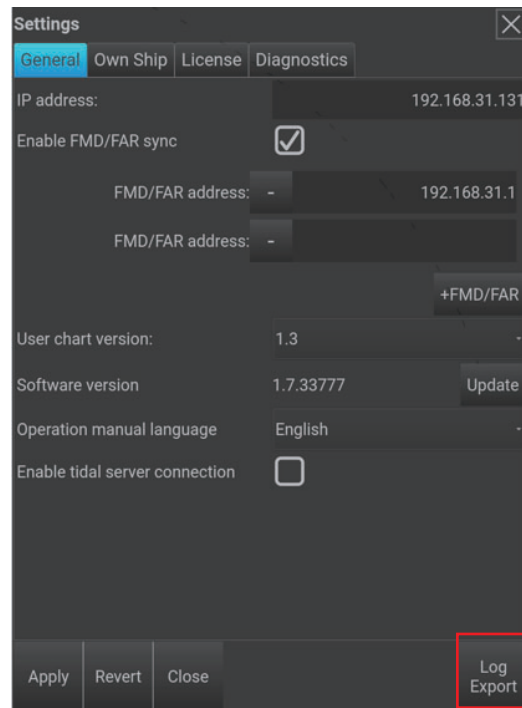

4. Tap the [Log Export] button to export the system log. The Confirmation window appears when exporting is finished.

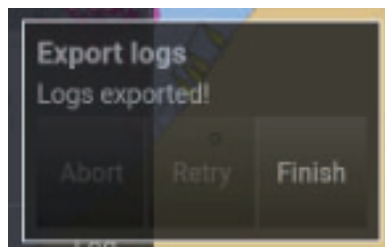
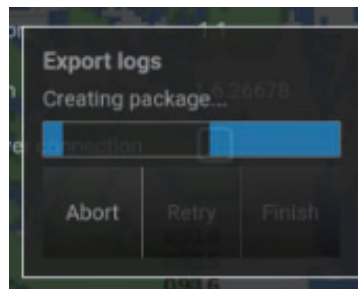

Display when log successfully exported

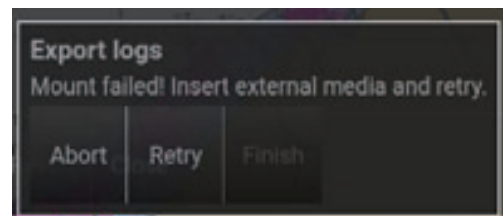

Display when log export failed

**Note:** If system log is could not be exported, the message "Mount failed! Insert external media and retry" appears. Tap the [Retry] button to restart exporting. To cancel exporting, tap the [Abort] button.

5. Tap the [Finish] button to close the window.

## 14. MAINTENANCE AND TROUBLESHOOTING

This page is intentionally left blank.

# APPENDIX 1 CONTEXT MENUS

Mode	Target	Menu item	Function
Standard mode (Disabled during [Manage Charts] mode)	On chart	[Pick report]	Show the chart object information.
		[Chart legend]	Show the chart legend.
		[Weather Legend]	Show the weather legend.
Divider (on [Measure] menu)	Divider point	[Remove divider point]	Delete a divider point.
	Divider line	[Split divider]	A circle is displayed at the center of the divider line. The distance between the divider point and the circle is displayed. The circle can be dragged to change the location on the line.
	Divider when [split divider] is used	[Join divider]	Release [Split divider] to return to the normal Divider.
User Chart	Line or Area point	[Remove point]	Delete a point.
	Line or Area line	[Insert point]	Add a point on a line.
	Line or Area point (Center point of the user chart object)	[Edit point]	Change the Lat/Lon location of the point.
	User chart object	[Copy]	Copy a user chart object.
		[Properties]	Show the object information.
	On chart	[Paste]	Paste the copied object.
	User chart object list	[Center chart to]	Center the selected object on the display.
		[Copy]	Copy the selected object.
		[Delete]	Delete the selected object.
		[Paste]	Paste the copied object.
	User chart object list (when the check box on the list is checked)	[Copy selected objects]	Copy all the objects selected.
		[Delete selected objects]	Delete all the objects selected.
	Import/Export	[Select All]	Select all the files.
		[Select None]	All the selected files are deselected.
		[Invert Selection]	Inverses the selection status of selected/unselected files.
[Sort by Name]		Show the file order based by file name.	
[Sort by Extension]		Show the file order based by extension.	
Voyage Log (on [Own Ship] menu)	Description cell	[Edit Description]	Tap the description cell to edit.
	Chart Usage-Export	[Create directory]	Create directory for a USB flash memory.

Mode	Target	Menu item	Function
Route	Waypoint	[Delete WPT]	Delete a waypoint.
		[Show WPT in list]	Show selected waypoint on the waypoint list.
	Leg	[Insert WPT]	Add a waypoint to a leg.
		[Insert parallel line]	Show the parallel index lines.
		[Set asymmetric XTD]	Set asymmetric XTD for a leg. (Tap and hold the XTD on the leg to show and set.)
	Parallel line	[Delete parallel line]	Delete a parallel index line.
	Waypoint list -Checkbox	[Center chart to]	Center the selected waypoint on the display.
		[Copy selected WPTs]	Copy the checked (selected) waypoint(s).
		[Select from prev mark]	Select all the checkmarked waypoints.
		[Paste before]	Paste the copied waypoint into the route, before the selected waypoint.
		[Paste after]	Paste the copied waypoint into the route, after the selected waypoint.
		[Delete selected WPTs]	Delete checkmarked waypoint(s).
		[Select to next mark]	Select all waypoints that are checkmarked between the two selected waypoints.
		[Show first selected row]	Show the first checked waypoint on the list.
		[Show last selected row]	Show the last checked waypoint on the list.
		Waypoint list -Name	[Edit selected WPT names]
	[Edit WPT name]		Change the name for a waypoint.
	[Insert before WPT]		Add waypoint before a waypoint.
	[Insert after WPT]		Add waypoint after a waypoint.
	[Delete selected WPTs]		Reset the waypoint selected in the checkbox.
	[Delete WPT]		Reset a waypoint.
	[Center chart to]		Center the chart on the display.
	[Copy selected WPTs]		Copy the waypoint selected in the checkbox.
	Waypoint list -Position	[Edit WPT position]	Change latitude/longitude for a waypoint.
		[Insert before WPT]	Add waypoint before a waypoint.
		[Insert after WPT]	Add waypoint after a waypoint.
		[Delete selected WPTs]	Reset the waypoint selected in the checkbox.
		[Delete WPT]	Reset a waypoint.
		[Center chart to]	Center the chart on the display.
		[Copy selected WPTs]	Copy the waypoint selected in the checkbox.
	Waypoint list -RAD NM	[Edit turn radius]	Change the turn radius value.
		[Edit selected turn radiuses]	Change the turn radius value for the waypoint selected in the checkbox.
	Waypoint list -XTD (title)	[Enable asymmetrical XTDs]	Change the XTD title from symmetrical to asymmetrical.
		[Use symmetrical XTDs]	Change the XTD title from asymmetrical to symmetrical.

Mode	Target	Menu item	Function
Route	Waypoint list -XTD (cell)	[Edit XTD]	Change the XTD value.
		[Edit selected XTDs]	Change the XTD for the waypoint selected in the checkbox.
		[Edit port XTD]	Change the port XTD value.
		[Edit selected port XTDs]	Change the port XTD for the waypoint selected in the checkbox.
		[Edit starboard XTD]	Change the starboard XTD value
		[Edit selected starboard XTDs]	Change the starboard XTD for the waypoint selected in the checkbox.
	Waypoint list -Margin m	[Edit safety margin]	Change the safety margin for a waypoint.
		[Edit selected safety margins]	Change the safety margin for the waypoint selected in the checkbox.
	Waypoint list -PL m (title)	[Show two parallel lines]	Show [PL m] and [PL1 m].
		[Show only one parallel line]	Show [PL m] only.
	Waypoint list -PL m (cell)	[Edit parallel line]	Change the parallel index line for a waypoint.
		[Edit selected parallel lines]	Change the parallel index line for the waypoint selected in the checkbox.
		[Remove parallel line]	Reset the parallel index line for a waypoint.
		[Remove selected parallel lines]	Reset the parallel index line for the waypoint selected in the checkbox.
	Waypoint list -GC/RL	[Edit leg GC/RL geometry]	Change the GC/RL for a waypoint.
		[Edit selected leg GC/RL geometries]	Change the GC/RL for the waypoint selected in the checkbox.
	Waypoint list -Leg course	[Edit leg start course]	Edit the leg course for the final waypoint.
	Waypoint list -MIN kn	[Edit minimum leg speed]	Change the MIN kn for a waypoint.
		[Edit selected minimum leg speeds]	Change the MIN kn for the waypoint selected in the checkbox.
	Waypoint list -Speed kn	[Edit leg speed]	Change the speed kn for a waypoint.
		[Edit selected leg speeds]	Change the speed kn for the waypoint selected in the checkbox.
		[Unset leg speed]	Reset the set speed kn for a waypoint.
		[Unset selected leg speeds]	Reset the set speed kn for the waypoint selected in the checkbox.
	Waypoint list -MAX kn	[Edit maximum leg speeds]	Change the MAX kn for a waypoint.
		[Edit selected maximum leg speed]	Change the set MAX kn for the waypoint selected in the checkbox.
	Waypoint list -ETD/ETA (UTC/ local)	[Edit ETD/ETA] / [Unset ETD/ETA]	Set the value, or delete the ETD/ETA.
		[Unset selected ETD/ETAs]	Reset the set ETD/ETA for the waypoint selected in the checkbox.

APPENDIX 1 CONTEXT MENUS

Mode	Target	Menu item	Function
Route	Waypoint list -Time zone	[Edit time offset]	Change the time zone for a waypoint.
		[Edit selected time offsets]	Change the time zone for the waypoint selected in the checkbox.
		[Reset time offset]	Reset the set time zone for a waypoint.
		[Reset selected time offsets]	Reset the set time zone for the waypoint selected in the check box.
	Waypoint list -DST	[Edit DST]	Set one the following options: [±0], [+1] or [Automatic].
		[Edit selected DSTs]	Change the DST for the waypoint selected in the check box.
	Waypoint list -Draught m	[Edit draught]	Set the value.
		[Edit selected draughts]	Change the draught for the waypoint selected in the check box.
	Waypoint list -Check	[Show route check results]	Tap to open the [Route check results] window. See subsection 5.3.4.
	Import/Export	[Select All]	Select all the files.
		[Select None]	All the files will be deselected.
		[Invert Selection]	Inverses the selection status of selected/unselected files.
		[Sort by Name]	Show the file order based by file name.
		[Sort by Extension]	Show the file order based by extension.
Document	Folder/ file	[Create folder]	Create a new folder.
		[Copy]	Copy selected folder/file.
		[Delete]	Delete selected folder/file.
		[Move]	Move selected folder/file.
	Blank area	[Create folder]	Create a new folder.
	Import/Export	[Select All]	Select all the files.
		[Select None]	All the files will be deselected.
		[Invert Selection]	Inverses the selection status of selected/unselected files.
		[Sort by Name]	Show the file order based by file name.
		[Sort by Extension]	Show the file order based by extension.
Manage Charts mode	On chart	Select XXXXXXXX (X= indicates chart cell name)	Select XXXXXXXX chart (checked in check box on the chart list window).
		Open XXXXXXXX (X= indicates chart cell name)	Show the XXXXXXXX chart.
		Deselect XXXXXXXX (X= indicates chart cell name)	Deselect the XXXXXXXX on chart (the check box on the chart list window will be deselected).
	Chart list	Go to XXXXXXXX	Center the XXXXXXXX chart cell. The chart catalog of the cell name will be centered on the display.
		Open XXXXXXXX	Center the XXXXXXXX chart cell. The chart of the cell name will be centered on the display.

Mode	Target	Menu item	Function
Target	AIS/TT symbols	[Target info]	AIS/TT information for the selected target. Maximum five (5) target info windows for AIS and ten (10) for TT can be displayed at the same time.
	Safety Messages	[Select all] / [Deselect all]	Check or uncheck the safety messages.
		[Select messages above] / [Select messages below]	Available when multiple safety messages are received.
LOP (POSN fix)	Timestamp	[Set to current time]	After position is fixed on the chart, tap and hold the [Timestamp] cell to set to the current time.
	On chart	[Event info]	Show the user event information.
		[Add LOP observation]	Add point manually for LOP (Line of Position).

**SPECIFICATIONS OF PLANNING STATION  
PS-100**

The Planning Station PS-100 is an application for planning voyager routes. It makes the route plan easier on your chart.

**1 GENERAL**

- 1.1 Functions                      Route planning, Route monitoring, User chart, Own ship's mark, Weather forecast, ENC chart, Document viewer, Position fixing, Voyage log, Playback log, Radar overlay, Tidal overlay\*, Tools
  - 1.2 Mark/Data indications      Own ship's speed/course/position, Clock/ Time zone, Color palette, Screenshot, System reboot, Route, Chart, Search, Target tracking control, Graph\*, User interface switching, Safety message
- \*: future planning

**2 EQUIPMENTS REQUIRED**

- 2.1 Personal computer
  - Processor                      Intel Core i7 9Gen or later
  - Clock                            2.40 GHz or more
  - Memory                         RAM: 16 GB, SSD: 256 GB or more
  - Graphic board                 Nvidia Quadro P2200 or later
- 2.2 Touch monitor
  - Screen                         4096 x 2160 (4K)

**3 INTERFACE**

- 3.1 Number of port
  - LAN                              1 port, Ethernet 100Base-TX/1000Base-T, RJ45
- 3.2 Data sentences                IEC61162-1/2
  - Input                            GGA, GLL, GNS, HDT, OSD, THS, TLB, TTD, TTM, RMC, ROT, VBW, VDM, VDO, VHW, VTG, ZDA



# INDEX

---

## A

- Adjustment ..... 13-8
- AIS ..... 7-4
  - Filtering targets ..... 7-5
  - Safety messages..... 7-6
  - True scale activation ..... 7-4
- Alert settings ..... 6-8

## C

- Chart Catalog Legend ..... 3-7
- Chart Catalogue ..... 3-1
- Chart display settings..... 3-15
- Chart import log..... 3-4
- Chart synchronization ..... 1-4
- Chart usage log..... 4-5
- Connection status ..... 1-3
- Context Sensitive Operations..... 2-8
- Cursor Pick Function..... 2-8
- Cursor position ..... 2-8

## D

- Dead reckoning ..... 2-7
- Display brilliance ..... 2-15
- Divider ..... 8-3
- Documents ..... 6-6
  - Deleting documents ..... 12-7
  - Editing ..... 12-5
  - Exporting ..... 12-4
  - Free hand function ..... 12-6

## E

- EBL/VRM ..... 8-1
  - Ship and ground fixed EBL/VRM ..... 8-2

## F

- Free mode function ..... 2-11

## G

- Gate-1 ..... 3-5
- Graphical user interface ..... 2-3

## H

- HDG ..... 2-7

## I

- Importing documents..... 12-1
- Importing public key ..... 3-3
- Installation Considerations ..... 1-1

## L

- License..... 2-1
  - Importing ..... 2-1
  - Renewing license ..... 2-2
- Line of Position..... 13-3
- Locking Display ..... 8-8

## M

- Manual Heading settings..... 2-7

- Manual Speed settings..... 2-7

## N

- North mark ..... 2-15

## O

- Operator's manual..... 9-3
- Own ship settings..... 9-2

## P

- Past track ..... 4-1
- Playback mode..... 4-4
- Position fixing ..... 13-1
  - Manually ..... 13-2
- Public key ..... 3-3

## R

- Radar echo..... 13-7
- Radar Overlay ..... 11-1
  - Activation..... 11-1
  - Modifying parameters..... 11-1
- Routes ..... 5-1
  - Creating route ..... 5-2
  - Deleting route ..... 5-11
  - Exporting route ..... 5-8
  - How to edit route ..... 5-11
  - Importing route ..... 5-7
  - Monitor mode ..... 5-14
  - Route Optimizing..... 5-18
  - Route related parameters..... 5-13
  - Save a route ..... 5-10
  - Suggested speed for a route..... 5-5

## S

- Screenshots ..... 12-2
- Selection of sensor source ..... 2-6
- Sensor Information..... 2-5
- Snap function ..... 8-4
- SPD ..... 2-7
- Status of charts ..... 3-4
- System log export ..... 14-3

## T

- Tidal graphic display ..... 8-7
- Tidal Information ..... 8-4
- Time zone ..... 2-12
- Touchscreen operation ..... 2-3
- Troubleshooting ..... 14-1
- True Motion reset..... 2-10
- TT ..... 7-3
  - Information ..... 7-3
  - Source ..... 7-3

## U

- User chart
  - Context menu ..... 6-7
  - Deleting user chart ..... 6-12

## INDEX

Saving user chart .....6-11

### **V**

Vector length .....4-6

Voyage log .....4-2

### **W**

Weather Data .....10-1

How to delete weather data .....10-6

Information display .....10-4

Selecting weather data.....10-2