

FURUNO

OPERATOR'S MANUAL

*SHIP SECURITY
ALERT SYSTEM (SSAS)
USCG Version*

MODEL **IC-307**

 **FURUNO ELECTRIC CO., LTD.**

www.furuno.co.jp

TABLE OF CONTENTS

SYSTEM CONFIGURATION	ii
1. OVERVIEW OF SSAS	1
2. INSTALLATION.....	3
2.1 Mounting	3
2.1.1 Junction box (for FELCOM 16/19)	3
2.1.2 SSAS alert unit.....	4
2.2 Wiring.....	6
2.2.1 Junction box (for FELCOM 16/19)	6
2.2.2 SSAS alert unit.....	7
2.3 Enabling USCG Version.....	8
OPERATION	9
3.1 Operation Mode	9
3.1.1 Changing the password.....	9
3.1.2 SSAS manager mode	10
3.2 Setting SSAS Report Destination and Message Contents	11
3.3 Transmitting SSAS Report	15
3.4 Testing the Button	16
3.5 SSAS Report Test.....	20
4. WATERPROOFING KIT.....	21
OUTLINE DRAWINGS.....	D-1
INTERCONNECTION DIAGRAMS.....	S-1

SYSTEM CONFIGURATION

Regulations require at least two SSAS alert units.

FELCOM 15

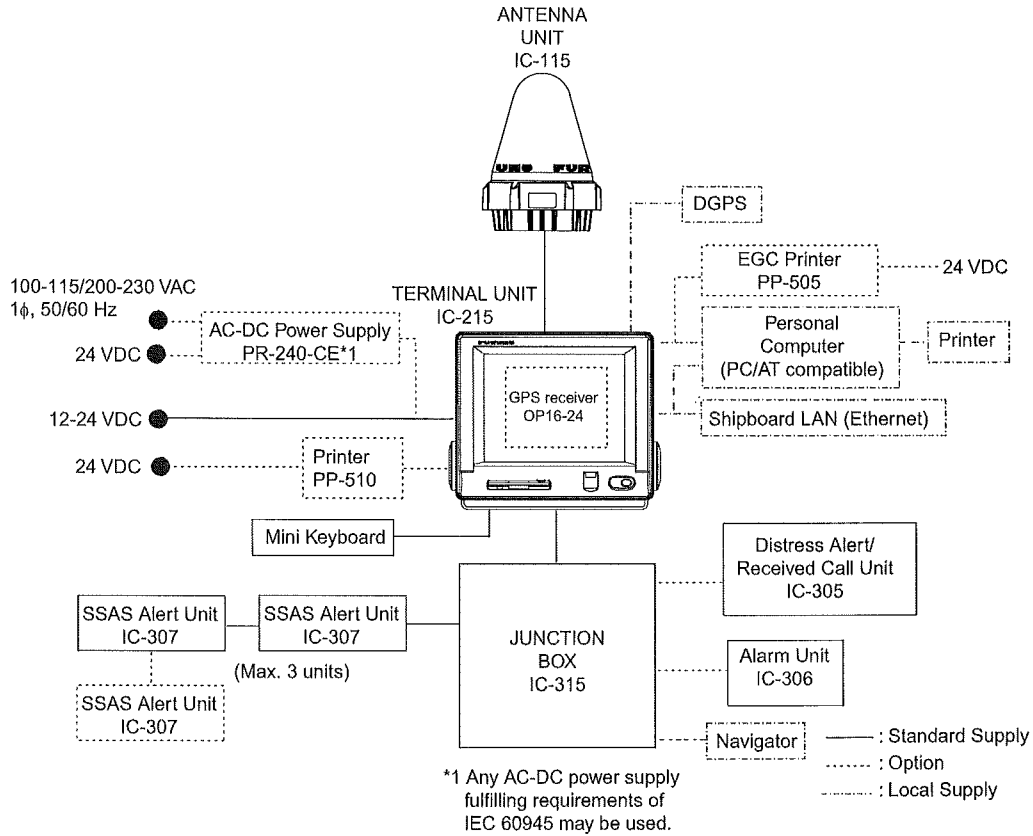

FELCOM 16

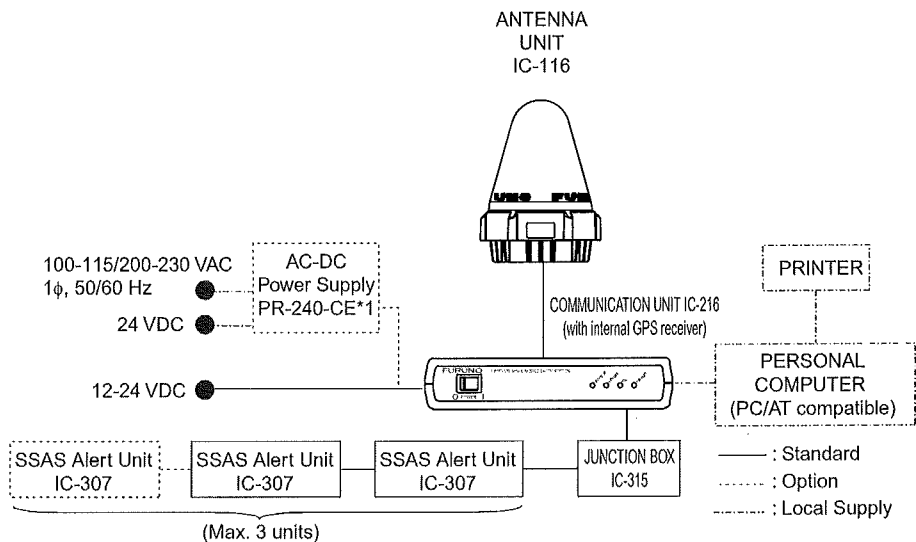

FELCOM 18

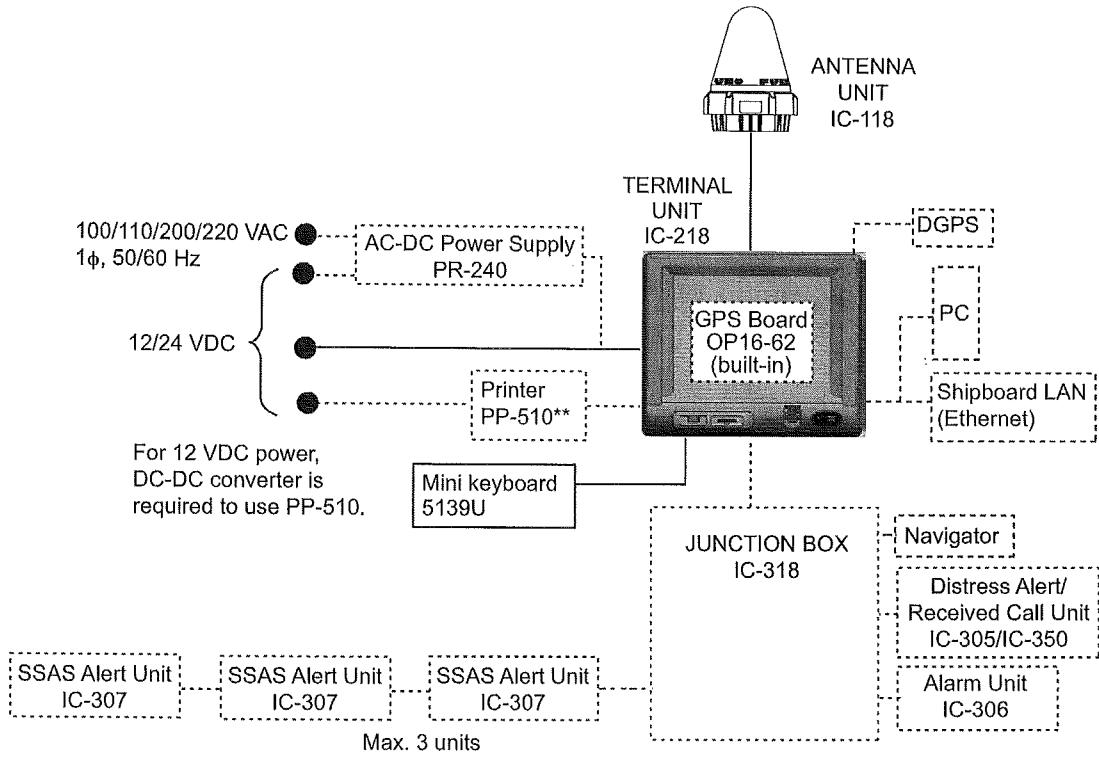

FELCOM 19

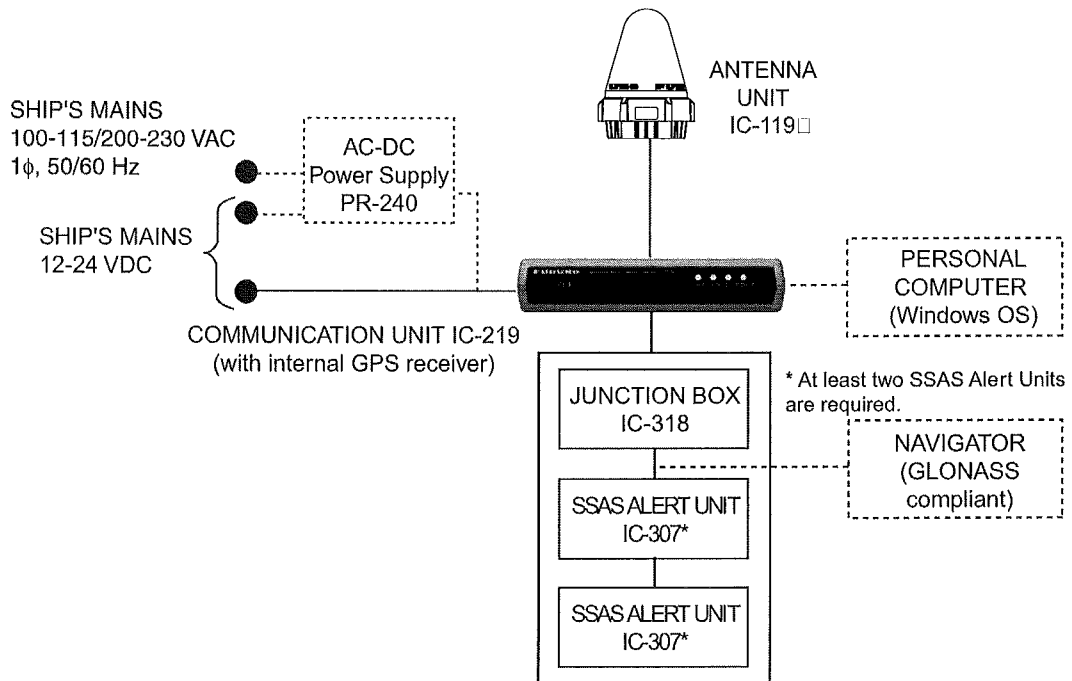

1. OVERVIEW OF SSAS

The IC-307 SSAS (Ship Security Alert System) Alert Unit connects to the Inmarsat-C MES FELCOM 15/18 or the Inmarsat Mini-C FELCOM 16/19 for the purpose of alerting specified addresses (for example, your ship's company) that your ship is under attack by intruders. The SOLAS Resolution XI-2/6 requires vessels of 500 GT or more constructed before 01 July 2004 to install an SSAS.

When your ship is under attack an SSAS report, which contains your ship's name, MMSI No., position, etc. is sent to up to five locations, specified by the ship's captain or authorized personnel. No audible or visible alarm is generated while the SSAS report is being transmitted, to prevent discovery of the report by the intruders.

The SSAS is protected with a password to prevent unauthorized setting or testing of it by other than the ship's captain or authorized personnel.

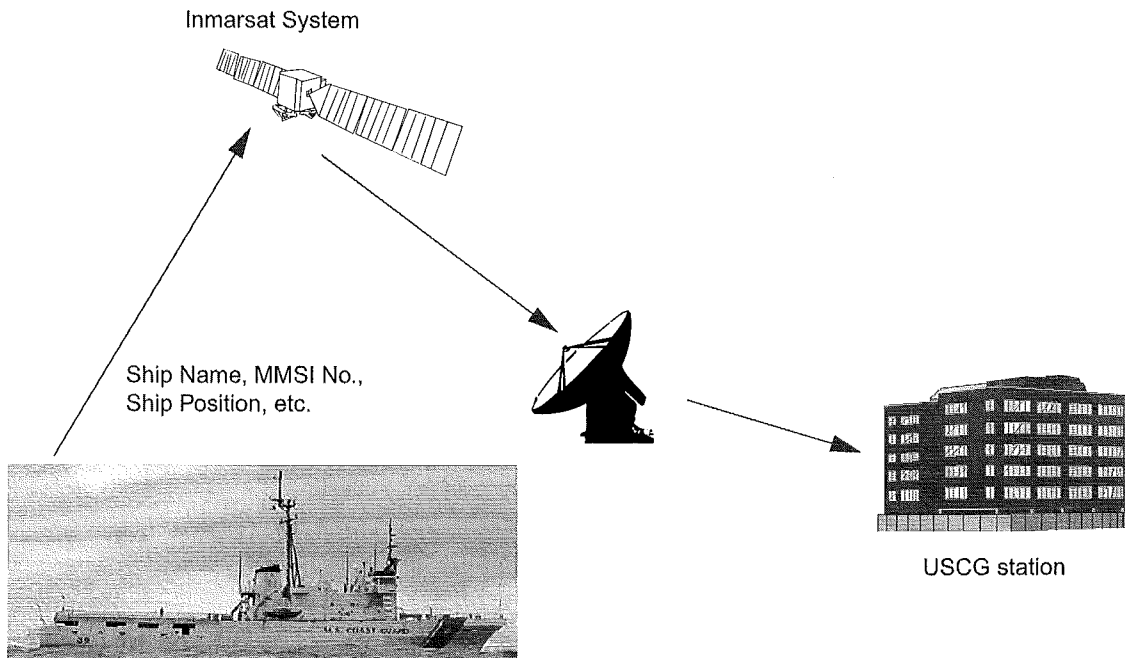

SSAS operation flow

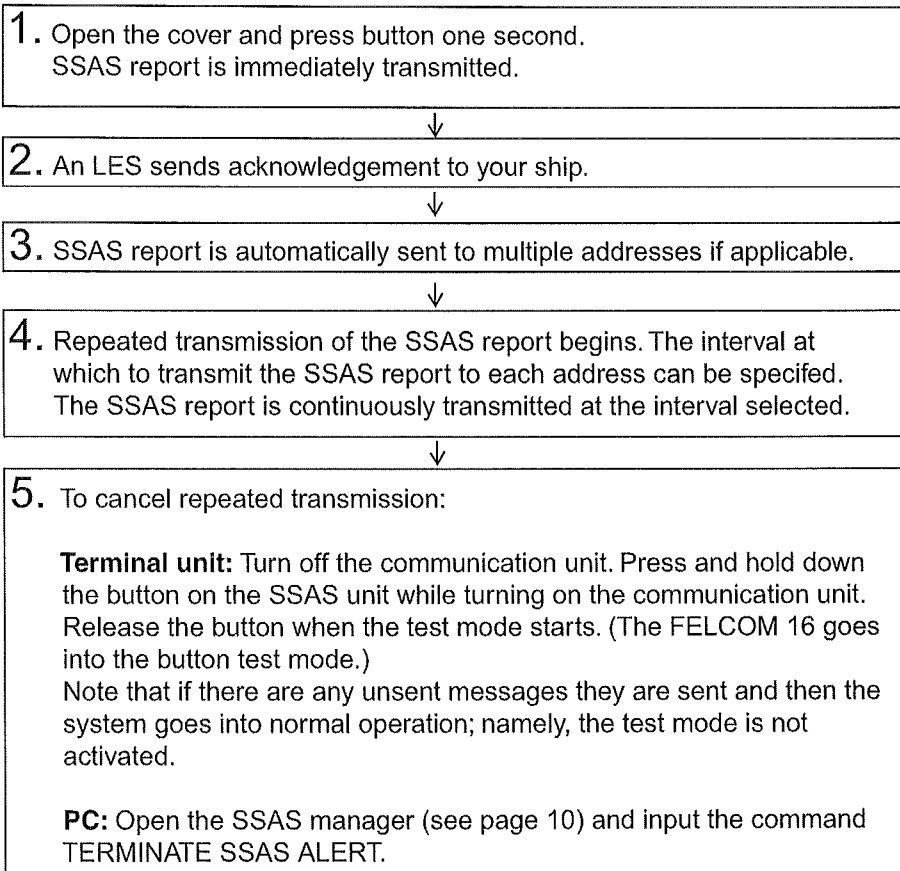

2. INSTALLATION

2.1 Mounting

2.1.1 Junction box (for FELCOM 16/19)

The junction box IC-315 is required when installing the SSAS on the FELCOM 16/19; it is already installed on the FELCOM 15/18.

Separate the junction box from a magnetic compass by the distances shown below to prevent deviation to a magnetic compass.

IC-315

Standard compass: 1.0 m

Steering compass: 0.70 m

IC-318

Standard compass: 0.90 m

Steering compass: 0.90 m

1. Remove four screws from the unit to separate the cover from the unit.
2. Fix the unit to the mounting location with four self-tapping screws (4x16, supplied).
3. Connect the cables appropriately referring to paragraph 2.2.1.

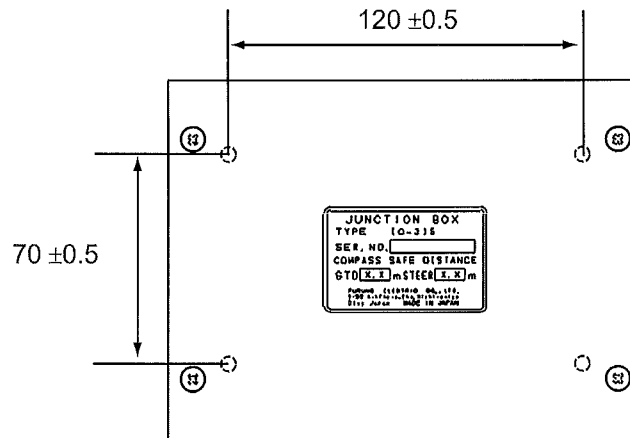

Junction box IC-315/318

The junction box is connected to the communication unit with a 2 meter cable, with D-sub connector (at the communication unit). Therefore, locate the junction box within two meters of the communication unit.

2.1.2 SSAS alert unit

Separate the junction box from the SSAS alert unit by the distances shown below to prevent deviation to a magnetic compass.

Standard compass: 0.70 m

Steering compass: 0.45 m

Locate the SSAS alert unit where it cannot be found by intruders. The location should be known only by ship's captain and authorized personnel.

Bulkhead mounting

1. Remove four screws from the unit to separate the bottom chassis from the top cover.
2. Fix the unit to the mounting location with four self-tapping screws (supplied).
3. The cable can be lead in from the bottom or the rear panel. For rear panel entrance, change the clamp orientation as follows:
 - a) Unfasten three screws to remove the cable clamp.
 - b) Turn the clamp 90 degrees.
 - c) Refasten the clamp with three screws unfastened at step a) to fix the clamp.

Unfasten three screws.

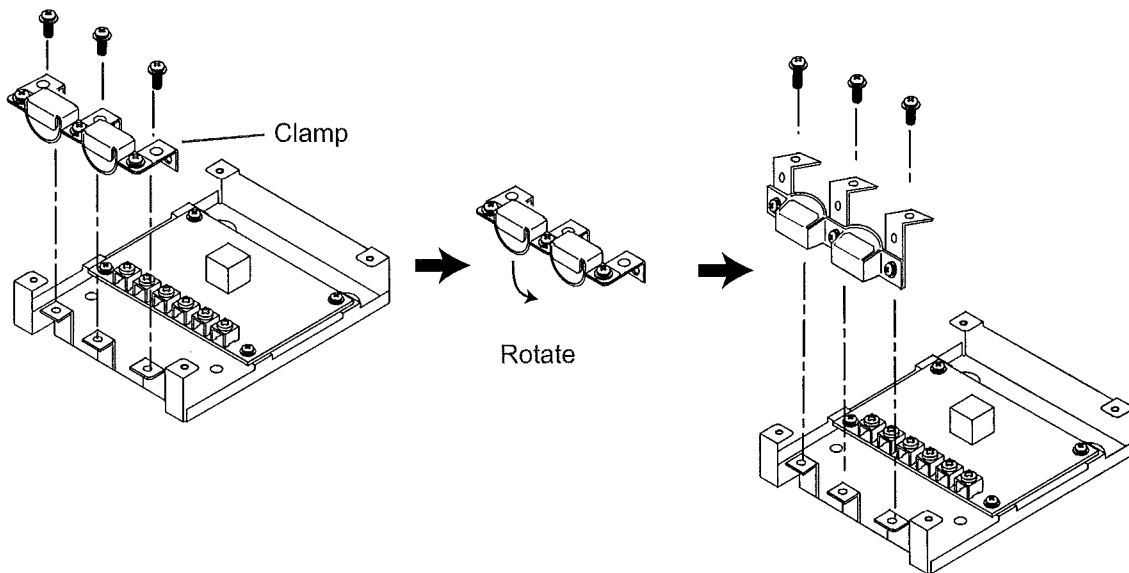

Fasten three screws.

4. Run the cable thru one of the cable entrances and connect it to terminal board.

- Attach the switch cover as shown below. Note that the cover may also be rotated 180 degrees.

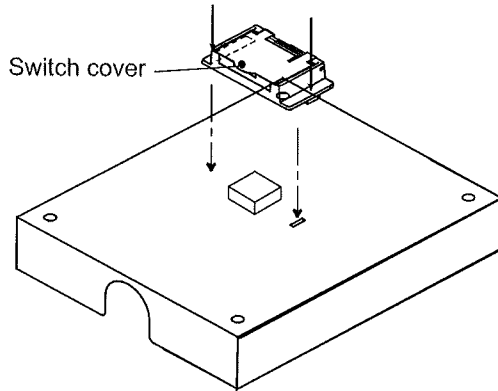

Flush mounting

The optional flush mount kit OP16-28 (Code No. 004-448-010) is required.

Name	Type	Code No.	Qty	Remarks
Fixture	16-018-7201-1	100-317-931	1	
Pan head screw	M3x6	000-800-362	4	
Self-tapping screw	4x16	000-802-080	4	

- Cut out the mounting position referring to the outline drawings at the back of this manual.
- Fix the unit to the fixture with four pan head screws (supplied).
- Fasten the fixture with the unit to the mounting location with four self-tapping screws (supplied).
- Attach switch cover as shown above.

2.2 Wiring

2.2.1 Junction box (for FELCOM 16/19)

Use the junction box IC-315 to connect the SSAS alert unit to the FELCOM 16, or the junction box IC-318 to connect the SSAS alert unit to the FELCOM 19. Unfasten four screws to remove the cover to connect cables to terminal board. For detailed wiring information see the interconnection diagram.

For connecting the SSAS alert unit IC-307, use the JIS cable TTYCS-4 (or equivalent, see next page for sectional view of this cable) or the CO-SPEVV-SB-C 0.2x5P. When using the CO-SPEVV-SB-C 0.2x5P cable, replace the cable clamp with the cable clamp 16-018-6008-1, supplied with the junction box. For connecting the communication unit IC-216, use cable 16S0344.

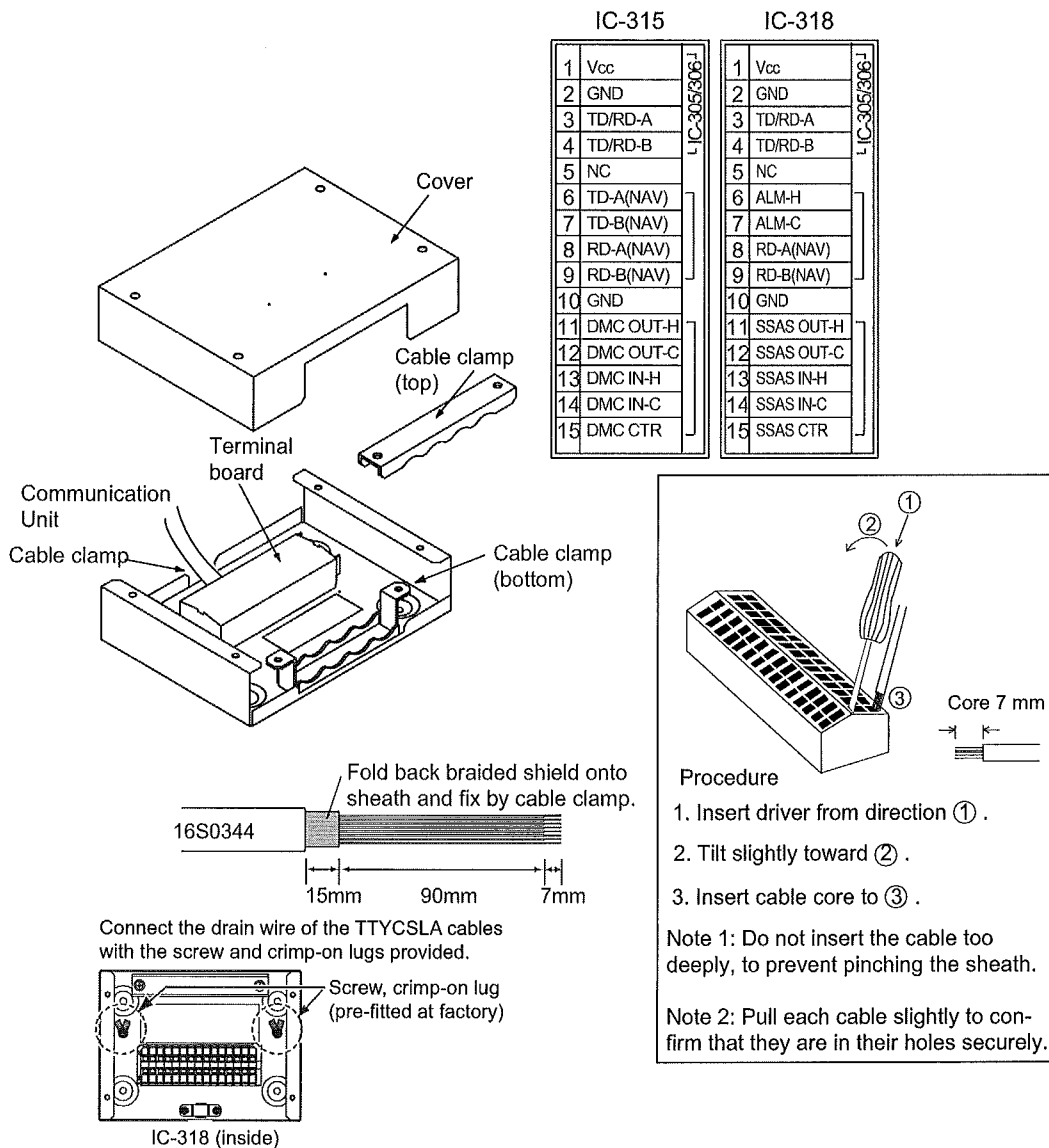

2.2.2 SSAS alert unit

Three SSAS alert units can be connected. For wiring, see the illustrations below and the interconnection diagram at the back of this manual. For the terminal unit (FELCOM 15/18) and the communication unit (FELCOM 16/19), the wiring of the SSAS is monitored and if in error "TROUBLE: SSAS UNIT connection abnormality." is displayed. Further the ERROR lamp (FELCOM 16) flashes.

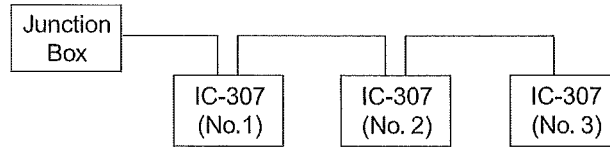

Connect wiring to the terminal board 16P0229 inside the SSAS alert unit. To differentiate between units in case of multiple unit installation, change jumper block settings as shown below, in accordance with how many units are installed.

Jumper settings for two IC-307

Jumper	Unit	No.1 unit*	No. 2 unit
JP1		No	Yes
JP2		Yes	No

No. 1 unit: Unit with two cables connected to it.
No. 2 unit: Unit with one cable connected to it.

Jumper settings for three IC-307

Jumper	Unit	No.1 unit*	No. 2 unit*	No. 3 unit
JP1		No	No	Yes
JP2		Yes	Yes	No

No. 1 and No. 2 units: Units with two cables connected to them.
No. 3 unit: Unit with one cable connected to it.

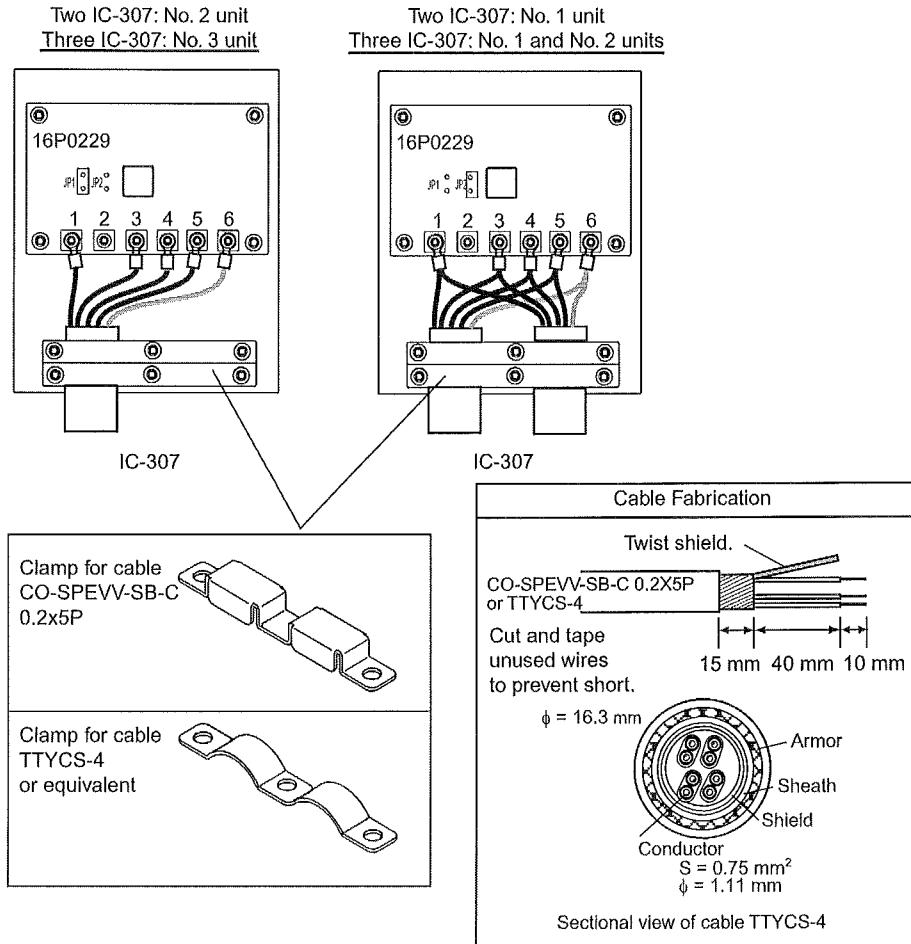

Wiring inside the SSAS alert unit

2.3 Enabling USCG Version

1. **FELCOM 15:** Press [F8], [2] to show the System Setup menu.
FELCOM 16/18/19: Press [F8], [1] to show the System Setup menu.
2. Press [↓] to choose Command Window and then press the [Enter] key.

Command Window

```

RFCONCPU ***
[ Main Menu ]
1. Remote Box Setup
2. Internal GPS Setup
Enter JOB No. : █
    
```

FELCOM 15/16

Command Window

```

[ Main Menu ]
1. Remote Box Setup
2. Internal GPS Setup
Enter JOB No. █
    
```

FELCOM 18/19

3. Type "furunoservice" (without quotation marks) in the Enter JOB No. field and then press the [Enter] key. The prompt PASSWORD appears.
4. Enter password (see FURUNO Information for SSAS) then press the [Enter] key. Then, the item Main Menu is displayed in reverse video.
5. Press [1], [Enter], [1], [Enter]. One of the following windows appears.

```

[ DMC ]
1. SSAS(IC-307)
2. DMC
3. OFF
4: SSAS(Momentary SW) E: Exit
Enter No.:
    
```

FELCOM 15

```

[ SSAS ]
1. ON(IC-307)
2. OFF
3: Momentary SW (for USCG)
E: Exit
Enter No.:
    
```

FELCOM 16

```

[ SSAS ]
1. OFF
2. IC-307 (Standard SSAS)
3: IC-307 (Russia SSAS)
4: SSAS (Momentary SW)
E: Exit
Enter No.:
    
```

FELCOM 18

```

[ SSAS ]
1. OFF
2. IC-307(Standard)
3: IC-307(Russian)
4: Momentary SW (for USCG)
E: Exit
Enter No.:
    
```

FELCOM 19

6. Press [4] (FELCOM 15) or [3] (FELCOM 16/18/19) to enable the USCG version.
7. Press the [Esc] key several times to close the menu.

3. OPERATION

3.1 Operation Mode

There are two menu operating modes:

- Normal mode:** Menus other than SSAS-related menus are displayed.
- SSAS manager mode:** The mode is activated by the password entered by the ship's captain or authorized personnel. The indication "SSAS Manager Mode" is shown at the top of the screen when this mode is activated, and it is flashing. All SSAS-related menus are available. Transmission of the SSAS report may be cancelled in this mode. The equipment starts up in the normal mode, regardless of the mode in use when the power is turned off.

3.1.1 Changing the password

The default password is "ship security alert". Ship's captain or authorized personnel may change the password as follows:

1. **FELCOM 15:** Press [F8], [2] to show the System Setup menu.
FELCOM 16/18/19: Press [F8], [1] to show the System Setup menu.
2. Press [↓] to choose Command Window and then press the [Enter] key.

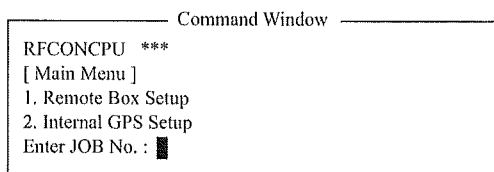

FELCOM 15/16



FELCOM 18/19

3. On the Enter JOB No. field, type "ssas password" (without quotation marks) and then press the [Enter] key. The prompt OLD PASSWORD appears.
4. Type your current password and then press the [Enter] key. The prompt NEW PASSWORD appears.
5. Enter new password, using at least six characters, and then press the [Enter] key. The prompt RETYPE NEW PASSWORD appears.

Note: If less than six characters are entered, the message "Please use a longer password." appears. Enter a longer password.

6. Enter new password again and then press the [Enter] key. The message "Password changed" appears.
7. Press the [Esc] key several times to close the menu.

Note: The SSAS manager mode cannot be accessed without the correct password.

3.1.2 SSAS manager mode

All SSAS-related settings are set in the SSAS manager mode. Do the following to access this mode.

1. **FELCOM 15:** Press [F8], [2] to show the System Setup menu.
FELCOM 16/18.19: Press [F8], [1] to show the System Setup menu.
2. Press [↓] to choose Command Window and then press the [Enter] key.

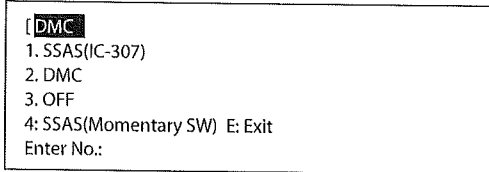

FELCOM 15

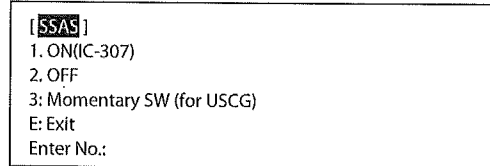

FELCOM 16/18/19

3. On the Enter JOB No. field, type "ssas manager" (without the quotation marks) and then press the [Enter] key.
Note: If there is no SSAS equipment connected, the message "Command Ignored: No SSAS button is installed." appears.
4. Type password and then press the [Enter] key to go into the "SSAS Manager Mode". The indication "SSAS Manager Mode" is shown at the top of the screen when this mode is activated, and it is flashing.

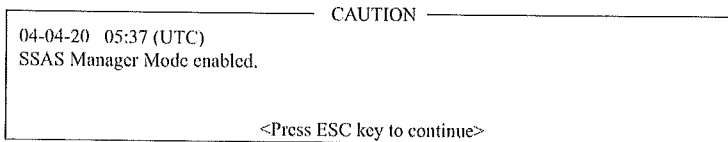

5. Press the [Esc] key several times to close the menu. This enables the SSAS manager mode, which allows you to execute the procedure in paragraph 3.2.

Note: Turn the power off and on again whenever changing SSAS-related settings.

3.2 Setting SSAS Report Destination and Message Contents

When the SSAS is activated, the SSAS report is sent according to the addresses (max. 5) and message content set with SSAS Report 1 – SSAS Report 5 on the SSAS Report menu.

Note 1: The destination and message content of an SSAS report vary according to Administration. Therefore, set them as requested by ship's authorities. For information other than ship's name, MMSI no. and IMN no., set it manually with "Other Inf."

Note 2: The equipment must be in the SSAS manager mode to execute this procedure. See paragraph 3.1.2.

1. Press the [F5] to open the Reports menu.

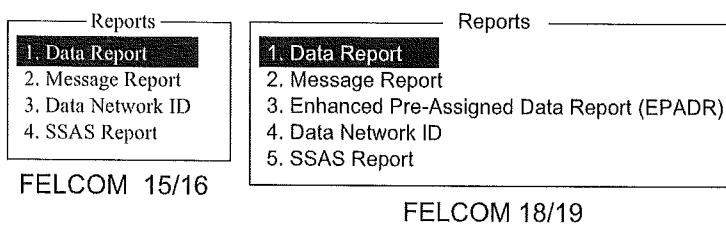

2. Press the [4] key to shown the SSAS Report menu.

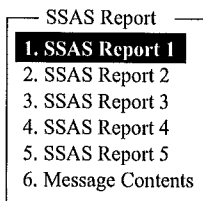

3. Press [1], [2], [3], [4] or [5] key as appropriate and then window below appears.

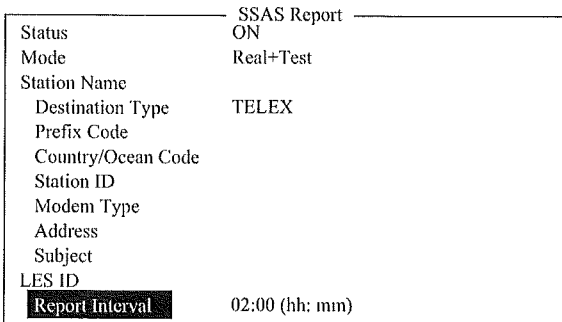

FELCOM 15/16

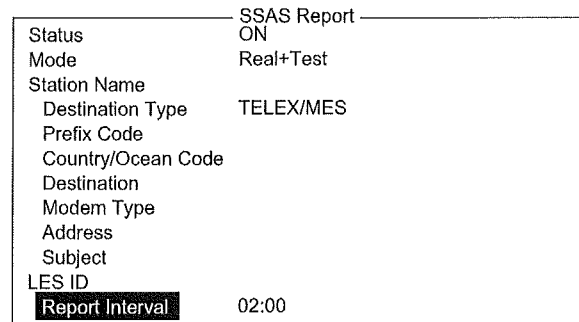

FELCOM 18/19

4. Press the [↓] key to choose Mode and then press the [Enter] key.

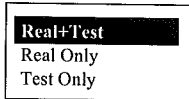

5. Press the [↑] or [↓] key to choose mode desired and then press the [Enter] key.

“Mode” defines what SSAS report(s) a station is to receive:

Real+Test: Actual SSAS report and test SSAS report.

Real Only: Actual SSAS report only.

Test Only: Test SSAS report only.

6. Press the [↓] key to choose Station Name and then press the [Enter] key.
7. Press the [↑] or [↓] key to choose appropriate station and then press the [Enter] key.
You may sort the list by group name, station name or communication type as follows:

Group name: Each press of [Ctrl] + [G] sorts the list by group name, ascending or descending order.

Station name: Each press of [Ctrl] + [N] sorts the list by station name, in ascending or descending order.

Comm. type: Each press of [Ctrl] + [T] sorts the list by communication type, in ascending or descending order.

8. Press the [↓] key to choose LES ID and then press the [Enter] key.
9. Press the [↑] or [↓] key to choose LES and then press the [Enter] key.

Note: Change the LES whenever sea area has changed. However, the equipment automatically searches for an LES with which you can communicate and the SSAS report is transmitted to that LES.

10. Press the [↓] key to choose Report Interval and then press the [Enter] key.
11. Enter time interval (00:10-99:59) to transmit the SSAS report and then press the [Enter] key.
12. Press the [Esc] key to open the Update window .

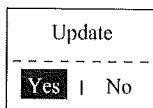

13. Yes is selected; press the [Enter] key to close the SSAS report window.

14. Press the [6] key to display the SSAS Message Contents menu.

SSAS Message Contents	
Vessel Name :	_____
MMSI :	_____
IMN :	_____
Other Inf. :	_____

LAT:	34: 44. 46N
LON:	135: 21. 26E
Time:	02/04/2012 04:31:48 (UTC)
COURSE:	071 deg
SPEED:	00 kt
Time:	02/04/2012 04:31:48 (UTC)

FELCOM 15/16

SSAS Message Contents	
Vessel Name :	_____
MMSI :	_____
IMN :	_____
IMO :	_____
Other Inf. :	_____

LAT:	34: 44. 46N
LON:	135: 21. 26E
Time:	02/04/2012 04:31:48 (UTC)
COURSE:	071 deg
SPEED:	00 kt
Time:	02/04/2012 04:31:48 (UTC)

FELCOM 18/19

15. Press the [Enter] key to open the Vessel Name window.
 16. Enter vessel's name and then press the [Enter] key.
 17. Press the [↓] key to choose MMSI and then press the [Enter] key.
 18. Enter MMSI number and then press the [Enter] key.
 19. Press the [↓] key to choose IMN and then press the [Enter] key.
 20. Enter IMN and then press the [Enter] key.
 21. Press the [↓] key to choose Other Inf. and then press the [Enter] key
 22. Enter appropriate message (for FELCOM15/16: three lines, for FELCOM18/19: six lines) and then press the [Enter] key.
- Note:** To shift between lines, use the [↑] or [↓] key.
23. Press the [Esc] key to open the Update window.
 24. Yes is selected; press the [Enter] key to close the SSAS Message Contents menu.
 25. Press the [Esc] key twice to return to the standby display.

Note 1: To delete entered subscriber's data, choose "Remove" from "Status."

Note 2: SSAS report settings may be saved to a floppy disk for backup.

FELCOM 15: [F8], [9], [6] to show the Save/Load window.

FELCOM 16: [F8], [8], [6] to show the Save/Load window.

FELCOM 18/19: [F8], [8], [6] to show the Export/Import window.

Save to FD	Load from FD
1. ALL 2. Station List 3. LES List 4. E-Mail Service List 5. SSAS Report* 6. Other	1. ALL 2. Station List 3. LES List 4. E-Mail Service List 5. SSAS Report* 6. Other

*: Available only in SSAS manager mode
 ("5.SSAS Report" is added in the SSAS manager mode and item numbers are shifted.)

FELCOM15/16

Export	Import
1. Sent Message 2. Received Message 3. EGC Message 4. Station List 5. LES List 6. E-Mail/SMS Service List 7. Test 8. Maintenance 9. Settings	1. Station List 2. LES List 3. E-Mail/SMS Service List 4. Settings

FELCOM 18/19

Note 3: To confirm the settings, follow paragraph 3.5.

3.3 Transmitting SSAS Report

The SSAS report is sent one second after the button on the SSAS is pressed. Repeated transmission can only be stopped from the SSAS manager mode.

1. Open the cover of the SSAS alert button.

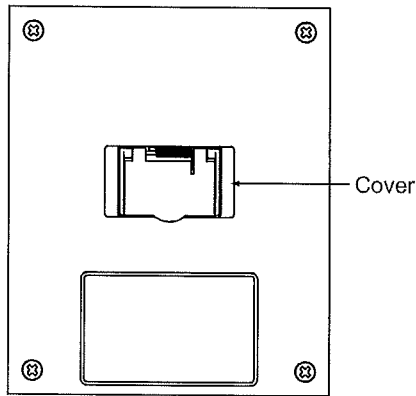

2. Push the button one second. The button is a momentary switch, meaning it is activated as soon as it is pressed one second.
3. The SSAS report is transmitted after the button is pushed one second. Below are the contents of the SSAS report.

```

--- SSAS ALERT MESSAGE ---
Vessel Name: Queen Elizabeth 2 ← Ship's Name
MMSI:      111660000 ← MMSI No.
IMN:      443100000 ← IMN No.
Help me! ← Desired message
LAT:      34:44.46N ← Own ship position in latitude
LON:      135:21.26E ← Own ship position in longitude
Time:     02/04/2004 04:31:48 (UTC) ← Time of position data
COURSE:   071 deg ← Course
SPEED:    00 kt ← Speed
Time:     02/04/2004 04:31:48 (UTC) ← Time of course and speed data
  
```

FELCOM 15/16

```

--- SSAS ALERT MESSAGE ---
Vessel Name: Queen Elizabeth 2 ← Ship's Name
MMSI:      111660000 ← MMSI No.
IMN:      443100000 ← IMN No.
IMO:      123456789 ← IMO No.
Help me! ← Desired message
LAT:      34:44.46N ← Own ship position in latitude
LON:      135:21.26E ← Own ship position in longitude
Time:     02/04/2004 04:31:48 (UTC) ← Time of position data
COURSE:   071 deg ← Course
SPEED:    00 kt ← Speed
Time:     02/04/2004 04:31:48 (UTC) ← Time of course and speed data
  
```

FELCOM 18/19

Note: If you accidentally push the button in, push it again within 30 seconds to cancel the report. The button pops out (■) and the report is not transmitted. When this is done, the message “INF: SSAS UNIT activation has been canceled.” appears on the display. Additionally, for the FELCOM 16/19, the POWER lamp on the communication unit flashes 30 seconds.

4. An LES sends acknowledgement to your ship.
5. For multiple destinations, steps 3 and 4 are automatically repeated (it is not necessary to push the button again).

Cancelling repeated transmission

Terminal Unit: Turn off the communication unit. Press and hold down the button on the SSAS unit while turning on the communication unit. Release the button when the test mode starts. (The FELCOM 16/18/19 goes into the button test mode.) Note that if there are any unsent messages they are sent and then the system goes into normal operation; namely, the test mode is not activated.

PC: Open the SSAS manager (see page 12) and input the command TERMINATE SSAS ALERT.

3.4 Testing the Button

The SSAS buttons can be tested as below.

Note 1: An actual SSAS report cannot be transmitted during the testing.

Note 2: The equipment must be in the SSAS manager mode to conduct the test.

FELCOM 15/18

1. Press the [F7] key to display the Options menu.
2. Press one of the following keys to display the Test menu:

- Operating mode is Inmarsat-C:** [7] key
- FELCOM 18:** [8] key
- Operating mode is EGC receiver:** [6] key

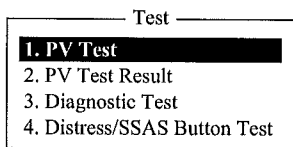

3. Press the [4] key.

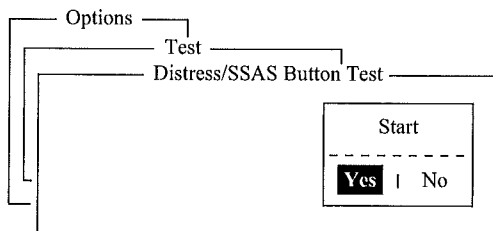

4. Press the [Enter] key to start the test.

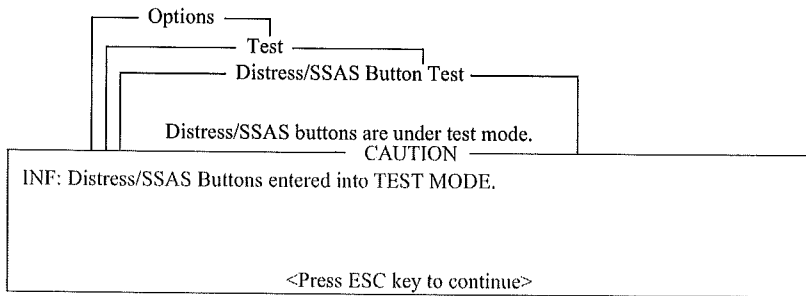

The display shows the message (in red) "Distress/SSAS buttons are under test. Cancel the test mode if a real distress/SSAS needs to sent." appears.

5. Open the button cover on the No.1 SSAS.
6. Push the button. The CAUTION window displays the message "SSAS UNIT works correctly." appears if the unit is functioning properly.
7. Five seconds after pressing the button the SSAS test report is automatically sent to station whose Mode set on the SSAS Report window is "Real+Test" or "Test Only".

Note: To test the No. 2 and No. 3 SSAS press appropriate button.

8. To escape from the test, press the [Esc] key twice on the terminal unit. The test mode is stopped and the message shown below appears to notify you that normal operation has been restored.

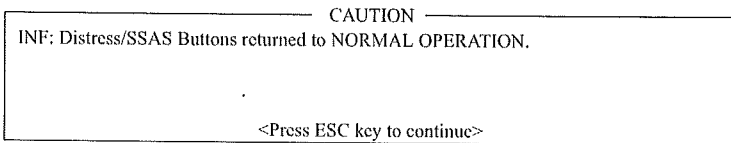

9. Press the [Esc] key three times to return to the standby display.

FELCOM 16/19, no PC

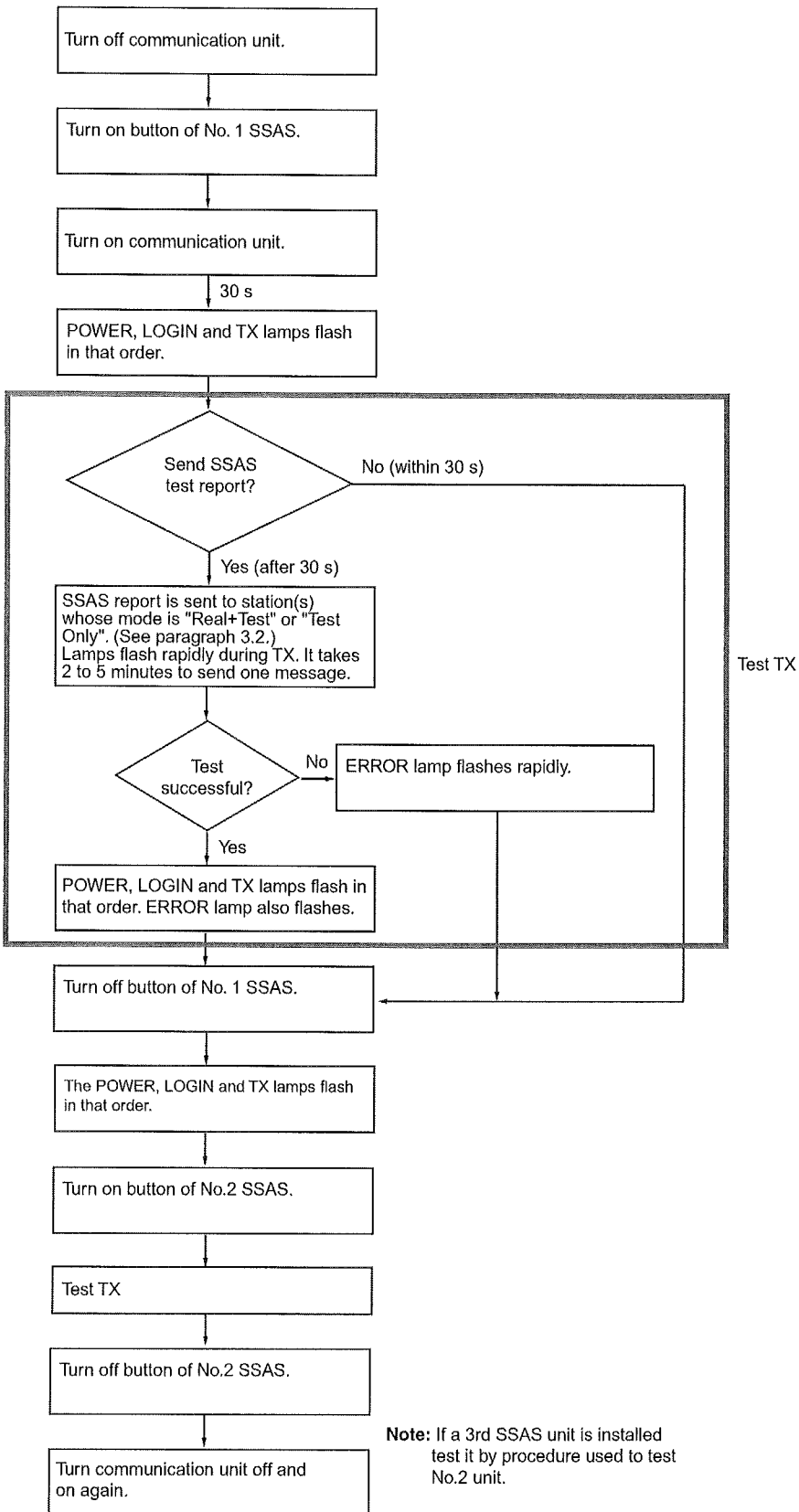

FELCOM 16/19, PC version

1. Press the [F7] key to display the Options menu.
2. Press the [7] key ([6] key when the FELCOM functions as an EGC receiver) to display the Test menu. For FELCOM 19, press the [8] key.

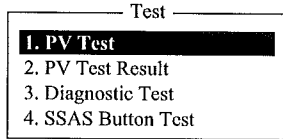

3. Press the [4] key.

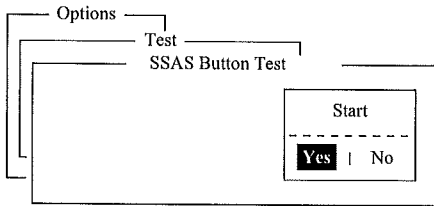

4. Press the [Enter] key to start the test.

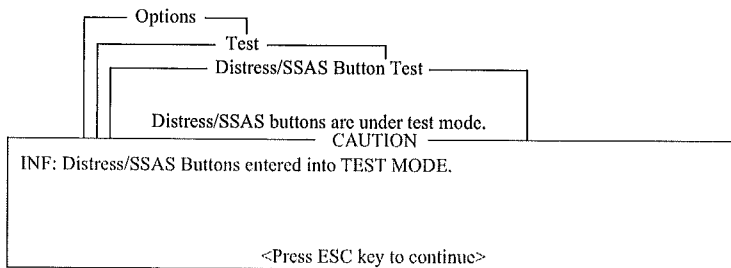

The display shows the message (in red) “SSAS buttons are under test. Cancel the test mode if a real SSAS alert needs to sent.” appears.

5. Open the button cover on the No. 1 SSAS.
6. Push the button. The CAUTION window displays the message “SSAS UNIT works correctly.” appears if the unit is functioning properly.
7. Five seconds after the button is pushed the SSAS test report is automatically sent to the station(s) whose Mode set on the SSAS Report window is “Real+Test” or Test Only”.

Note: To test the No. 2 and No. 3 SSAS press appropriate button.

8. To escape from the test, press the [Esc] key twice on the terminal unit. The test mode is stopped and the message shown below appears to notify you that normal operation has been restored.

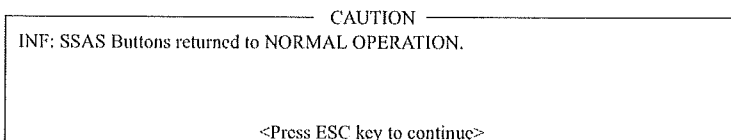

9. Press the [Esc] key three times to return to the standby display.

3.5 SSAS Report Test

You can test for successful transmission of the SSAS report to the address you specify, without using the button. The test report message states "!!! Test Call !!!" to alert the receiver of the message that it is a test call.

Note: This function is only available in the SSAS manager mode. Switch to this mode (see paragraph 3.1.2) and then follow this procedure.

1. Press the [F5] key to open the Reports menu.
2. Press the [4] key to choose the SSAS Report menu.
3. Press the [1], [2], [3], [4] or [5] key as appropriate, and the SSAS report setting menu appears.
4. Set destination where to transmit the test.
5. Press the [↑] key to choose Status and then press the [Enter] key.
6. Press the [↓] key to choose TEST and then press the [Enter] key.
7. Press the [Esc] key to open the Update window.
8. Yes is selected; press the [Enter] key. The test report is transmitted. After it is transmitted, "Status" is automatically set to ON.
9. Press the [Esc] key twice to return to the standby display.

4. WATERPROOFING KIT

To mount the IC-305 and IC-307 on a bulkhead, use the optional waterproofing kit to keep water splash out of the units.

Note: This kit cannot be used if the IC-305 or IC-307 is mounted face upward.

OP-xx (For IC-305)

Name	Type	Code No.	Qty
Fixing Tape	24-009-1225	100-366-200-10	2

OP-xx (For IC-307)

Name	Type	Code No.	Qty
Waterproofing Cover	16-023-5501	100-374-950-10	1
Fixing Tape	24-009-1225	100-366-200-10	2

1. Unfasten four screws to remove cover of IC-305/IC-307.
2. Attach supplied fixing to the underside of the cover as shown in the illustration below.

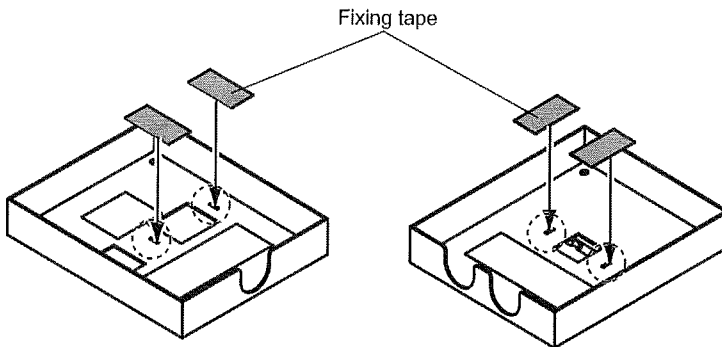

3. Attach the cover.
4. For IC-307, remove the seal from the waterproofing cover and attach the cover as shown in the illustration below.

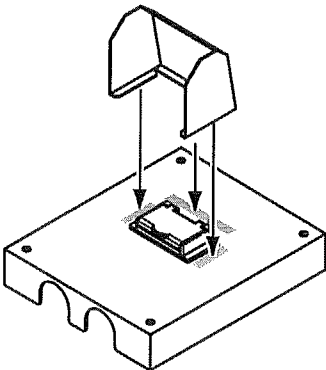

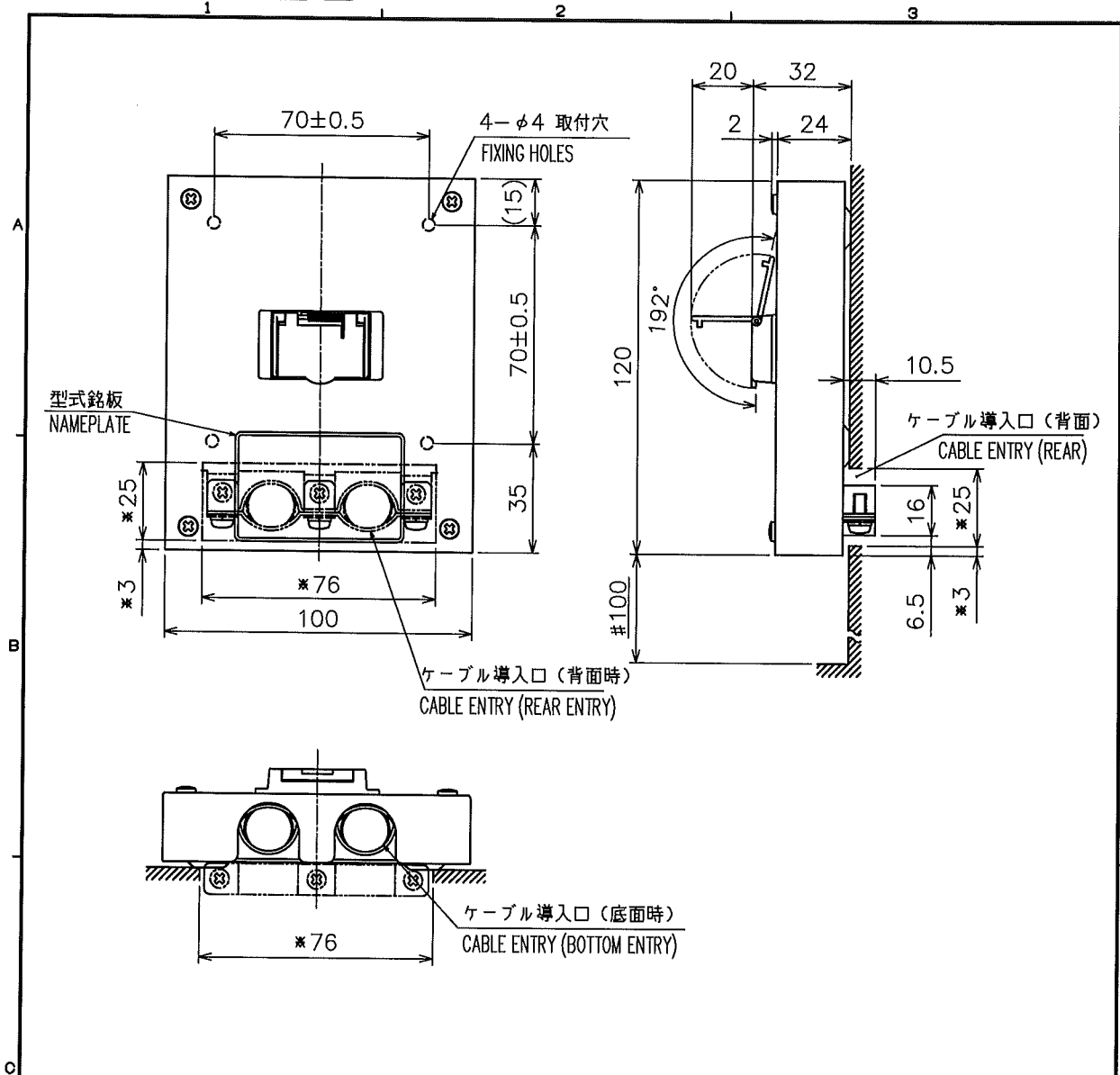

注 記

- 1) 指定外の寸法公差は表 1 による。
- 2) #印寸法は最小サービス空間寸法とする。
- 3) 取付用ネジはタッピンネジ呼び径 3×10 を使用のこと。
- 4) *印寸法は、ケーブルを背面から導入時に設ける穴の寸法

NOTE

1. TABLE 1 INDICATES TOLERANCE OF DIMENSIONS WHICH IS NOT SPECIFIED.
2. #: MINIMUM SERVICE CLEARANCE.
3. USE TAPPING SCREWS $\phi 3 \times 10$ FOR FIXING THE UNIT.
4. *: CUTOUT DIMENSIONS FOR REAR CABLE ENTRY.

表 1 TABLE 1

寸法区分 (mm) DIMENSION	公差 (mm) TOLERANCE
$L \leq 50$	± 1.5
$50 < L \leq 100$	± 2.5
$100 < L \leq 500$	± 3

DRAWN 5/Oct/2010 T.YAMASAKI		TITLE IC-307
CHECKED 5/Oct/2010 T.TAKAHASHI		名称 保安警報発呼器 (壁掛装備)
APPROVED 6/Oct/2010 Y.NISHIYAMA	FELCOM 12/15/16	外寸図
SCALE 1/2	MASS $0.35 \pm 10\%$ kg	NAME SSAS ALERT UNIT (BULKHEAD MOUNT)
DWG.No. C5635-G10-C	REF.No. 16-018-700G-3	OUTLINE DRAWING

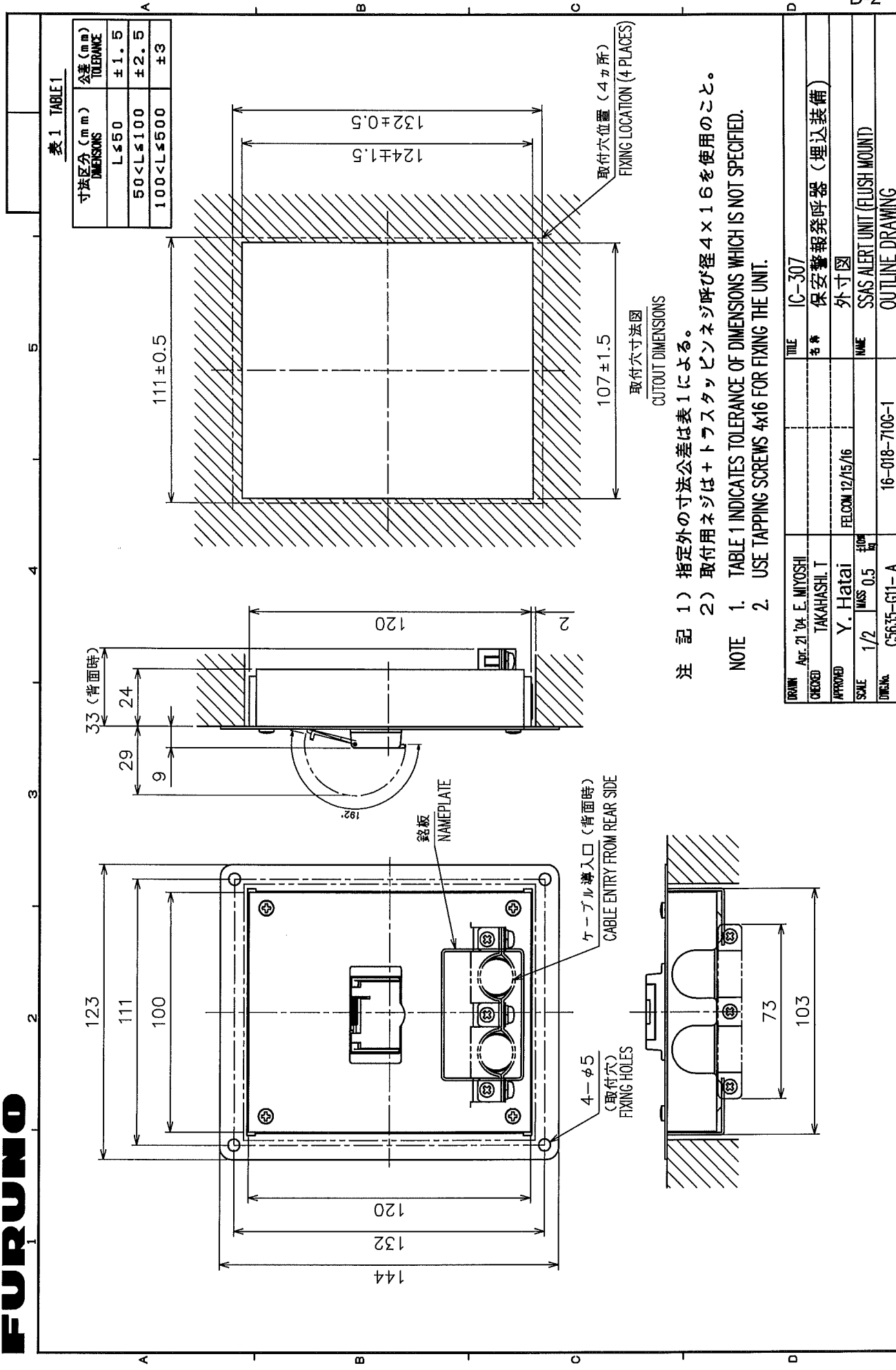

DRAWN	Apr. 21 '04	E. MIYOSHI	TITLE	IC-307
CHECKED		TAKAHASHI, T	名称	保安警報発呼器 (埋込装置)
APPROVED		Y. Hatai	図面番号	外寸図
SCALE	1/2	WISS 0.5	FEEDING DATE	12/15/16
DRAWING NO.	C5635-G11-A	16-018-710C-1	NAME	SSAS ALERT UNIT (FLUSH MOUNT)
				OUTLINE DRAWING

表 1 TABLE 1

寸法区分 (mm) DIMENSIONS	公差 (mm) TOLERANCE
$L \leq 50$	± 1.5
$50 < L \leq 100$	± 2.5
$100 < L \leq 500$	± 3

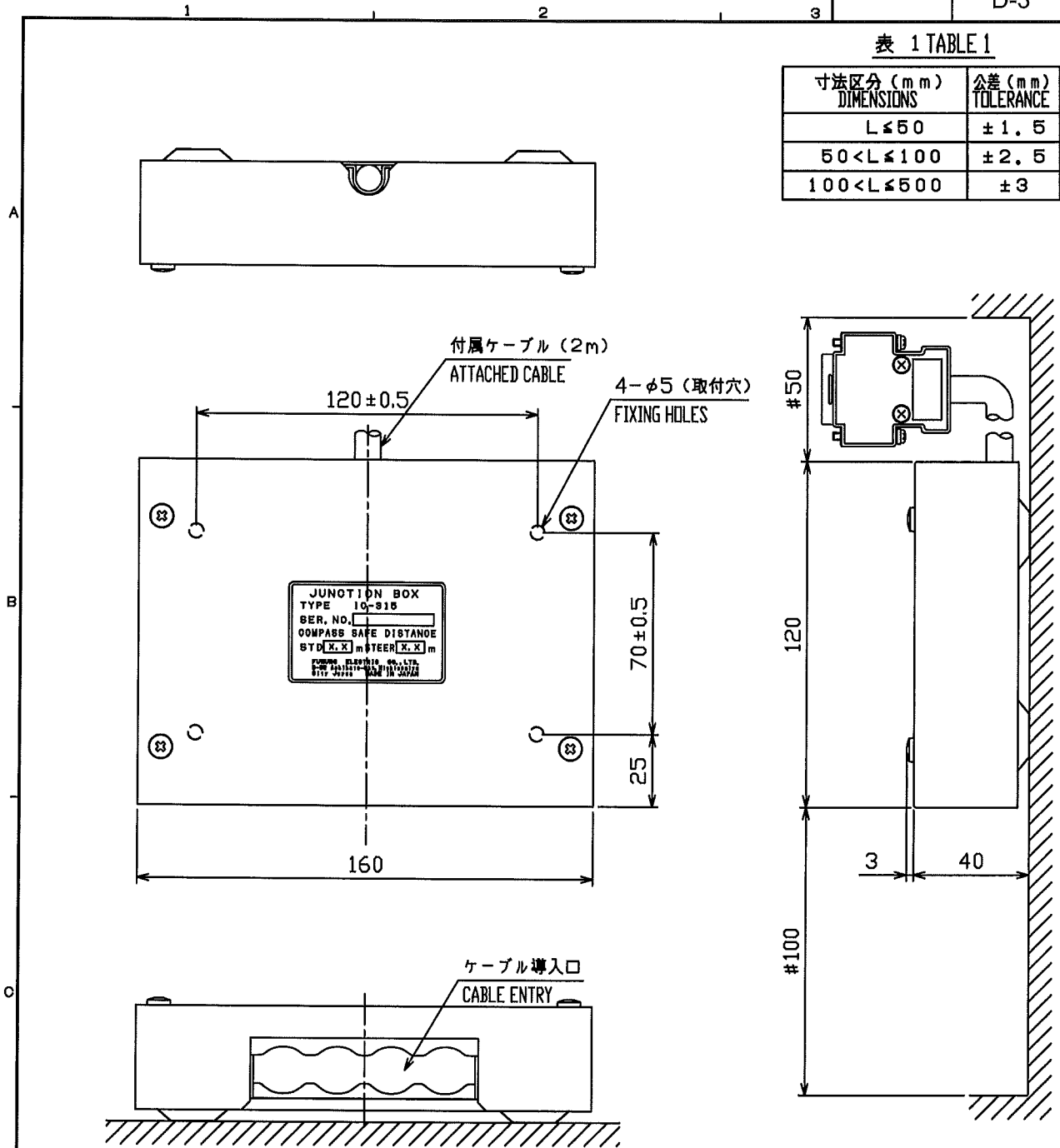

- 注 記 1) #印寸法は最小サービス空間寸法とする。
2) 指定外の寸法公差は表 1 による。
3) 取付用ネジは+タッピンネジ呼び径 4×16 を使用のこと。

- NOTE 1. # MINIMUM SERVICE CLEARANCE.
2. TABLE 1 INDICATES TOLERANCE OF DIMENSIONS WHICH IS NOT SPECIFIED.
3. USE SELF-TAPPING SCREWS 4x16 FOR FIXING THE UNIT.

DRAWN	Mar. 1 '05	T.YAMASAKI	TITLE	IC-315	
CHECKED	Mar. 1 '05	T.MATSUGUCHI	名称	接続箱	
APPROVED	Mar. 03 '05	T. Matsuguchi	FELCOM 15/16	外寸図	
SCALE	1/2	質量 $0.96 \pm 10\%$ kg	質量はケーブルを含む。 MASS W/ CABLE.	NAME	
DWG No.	C5635-G06-D		16-018-600G-2	JUNCTION BOX	
				OUTLINE DRAWING	

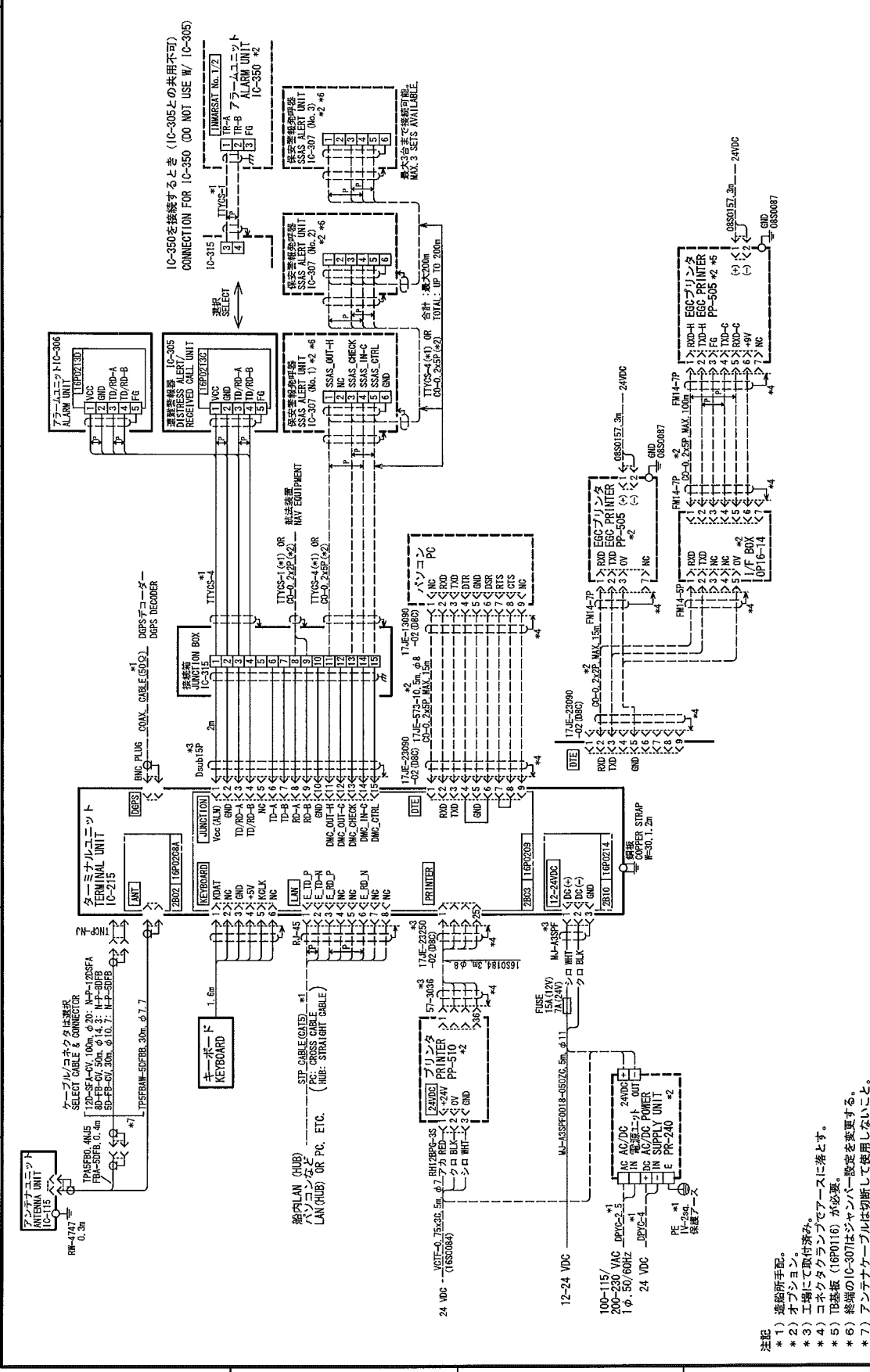

IC-350を接続するとき (IC-305との共用不可)
CONNECTION FOR IC-350 (DO NOT USE W/ IC-305)

基本3号まで接続可能
MAX. 3 SETS AVAILABLE.

合計: 最大200m
TOTAL: UP TO 200m

注記

- *1. 造船所手配。
- *2. オプション。
- *3. 工場にて取付済み。
- *4. コネクタケラランプでアースに落とす。
- *5. 基板 (16P0116) が必須。
- *6. 終端のIC-307はジャンパー設定を変更する。
- *7. アンテナケーブルは切断して使用しないこと。

NOTE

- *1. SHIPYARD SUPPLY.
- *2. OPTION.
- *3. FITTED AT FACTORY.
- *4. GROUND THRU CONNECTOR CLAMP.
- *5. TB BOARD (16P0116) REQUIRED.
- *6. CHANGE SETTING OF JUMPER IN IC-307 TO TERMINATE.
- *7. DO NOT SHORTEN ANTENNA CABLE.

DRWIN 20/Nov/2012, I. YAMASAKI
CHECKED 20/Nov/2012, T. TAKAHASHI
APPROVED 20/Nov/2012, Y. NISHIYAMA
SCALE MASS
DWG No. C5635-001-I

TITLE FELCOM 15
名称 インマルサットC船地球局
相互接続図
NAME INMARSAT-C MES
INTERCONNECTION DIAGRAM

CO-0.2x2P: CO-SPEVV-SB-C, 0.2x2P, φ10.5
CO-0.2x5P: CO-SPEVV-SB-C, 0.2x5P, φ13.5

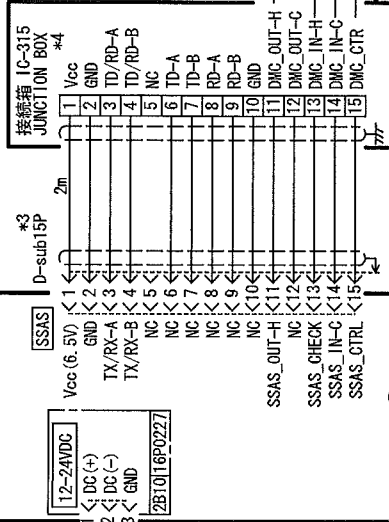
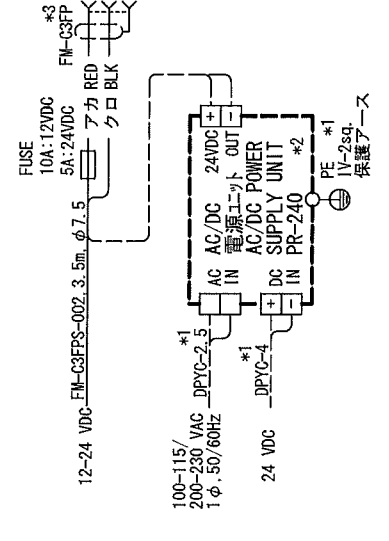
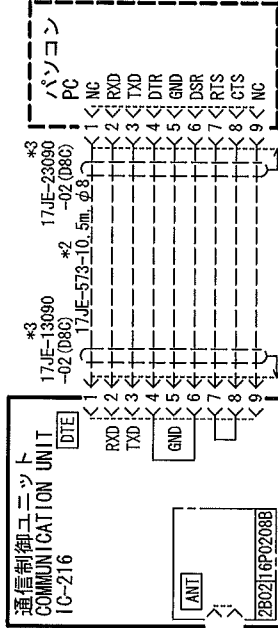
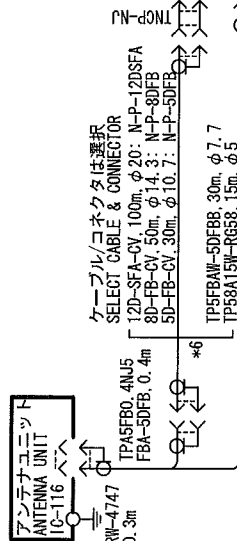

注記
*1) 造船所手配。
*2) オプション。
*3) 工場にて取付済み。
*4) SSAS仕様標準交絡。
*5) 終端のIC-307はジャンパー設定を変更する。
*6) アンテナケーブルは切断して使用しないこと。

NOTE
*1. SHIPYARD SUPPLY.
*2. OPTION.
*3. FITTED AT FACTORY.
*4. STANDARD SUPPLY FOR SSAS SPEC.
*5. CHANGE SETTING OF JUMPER IN IC-307 TO TERMINATE.
*6. DO NOT SHORTEN ANTENNA CABLE.

CO-0.2x5P: CO-SPEW-SB-C 0.2x5P, φ13.5

DRAWN	30/Mar/2010	I. YAMASAKI	TITLE	FELCOM 16
CHECKED	30/Mar/2010	T. TAKAHASHI	名称	インマルサットMINI-C携帯移動地球局
APPROVED	1/Apr/2010	Y.NISHIYAMA	相互結線図	
SCALE	MASS	kg	NAME	INMARSAT MINI-C MES
DMG No.	C5638-C01-L		INTERCONNECTION DIAGRAM	

