

# FURUNO

## OPERATOR'S MANUAL

MF/HF DSC TERMINAL

MODEL DSC-6/6A



**FURUNO ELECTRIC CO., LTD.**  
NISHINOMIYA, JAPAN

**©FURUNO ELECTRIC CO., LTD.**

9-52, Ashihara-cho,  
Nishinomiya, Japan 662

Telephone: 0798-65-2111  
Telefax: 0798-65-4200

All rights reserved. Printed in Japan

-Your Local Agent/Dealer

FIRST EDITION : NOV 1994  
G : JUN. 18, 1999

(TATA)

PUB. No. OME-55870  
DSC-6/6A





# SAFETY INSTRUCTIONS

"**DANGER**", "**WARNING**" and "**CAUTION**" notices appear throughout this manual. It is the responsibility of the operator of the equipment to read, understand and follow these notices. If you have any questions regarding these safety instructions, please contact a FURUNO agent or dealer.



**DANGER**

This notice indicates a potentially hazardous situation which, if not avoided, will result in death or serious injury.



**WARNING**

This notice indicates a potentially hazardous situation which, if not avoided, could result in death or serious injury.



**CAUTION**

This notice indicates a potentially hazardous situation which, if not avoided, could result in minor or moderate injury, or property damage.

<b>⚠ WARNING</b>	
	<p><b>Do not open the cover of the equipment.</b></p> <p>This equipment uses high voltage electricity which can shock, burn, or cause death. Only qualified personnel should work inside the equipment.</p>
<p><b>Do not disassemble or modify the equipment.</b></p> <p>Fire, electrical shock or serious injury can result.</p>	
<p><b>Immediately turn off the power at the ship's mains switchboard if water or foreign object falls into the equipment or the equipment is emitting smoke or fire.</b></p> <p>Continued use of the equipment can cause fire, electrical shock or serious injury.</p>	

<b>⚠ CAUTION</b>	
<p><b>Do not place liquid-filled containers on the top of the equipment.</b></p> <p>Fire or electrical shock can result if a liquid spills into the equipment.</p>	
<p><b>Do not place heater near the equipment.</b></p> <p>Heat can melt the power cord, which can result in fire or electrical shock.</p>	
<p><b>Do not operate the unit with wet hands.</b></p> <p>Electrical shock can result.</p>	
<p><b>Use the correct fuse.</b></p> <p>Use of the wrong fuse can cause fire or equipment damage.</p>	

**WARNING Label attached**

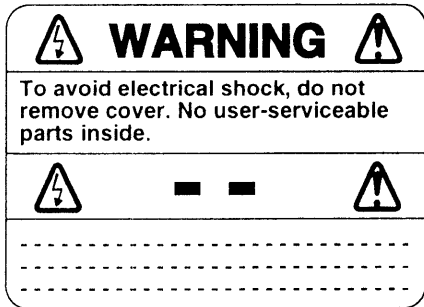

Name : Warning Label (1)  
 Type : 86-003-1011-0  
 Code No. : 100-236-230

# Introduction

## General

The FURUNO DSC-6/6A DSC Terminal provides the full range of distress and general calls on MF/HF bands, in full compliance with GMDSS requirements for class A DSC terminals.

## Difference between DSC-6 and DSC-6A

Since the DSC-6A incorporates 2187.5 kHz watch receiver, the antenna is provided for the DSC-6A. The operations of the DSC-6 and DSC-6A are completely the same.

Model	Antenna	Operation
DSC-6	Not provided	Same
DSC-6A	Provided (2187.5 kHz continuous watch)	

## About this manual

This manual mainly consists of two parts: PART 1, Operation, and PART 2, Maintenance.

### PART 1

PART 1 provides operating information. For sake of easy understanding, instruction is arranged by type of operation.

Once you become acquainted with the basic rules of operation, the function and logical layout of the DSC-6/6A man-to-machine dialogue will become more apparent. Therefore, please read "Overview" and "1. Basic Operation" to acquaint yourself with the basics of this unit.

### PART 2

This part contains the information necessary for conducting checks of the equipment. If you think something is wrong with the unit, refer to this part.

# The DSC-6/6A System

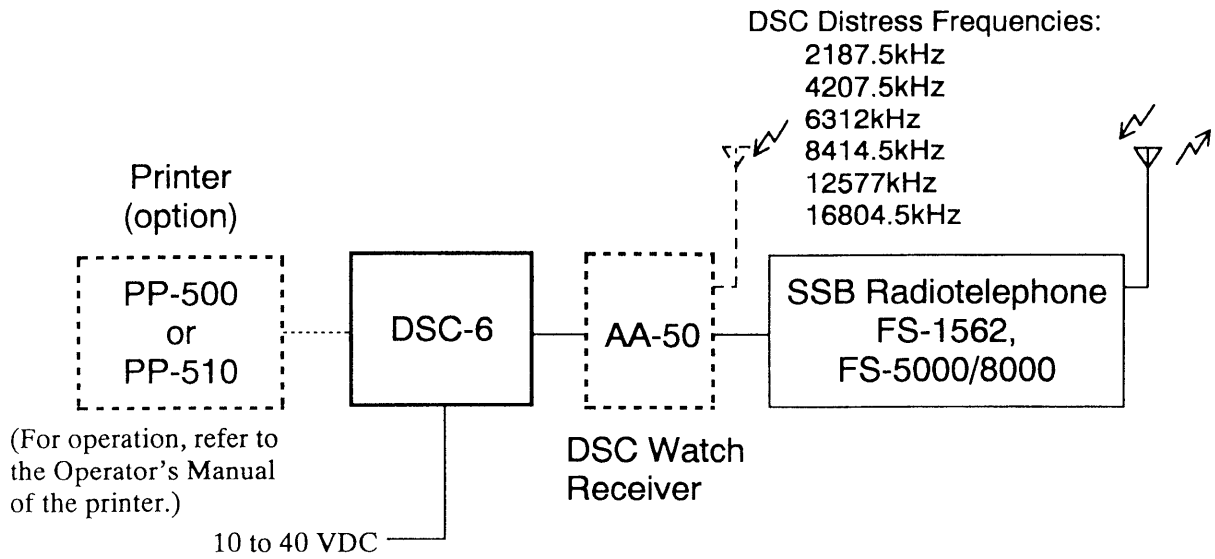

## DSC-6 System (for A3/A4 Area)

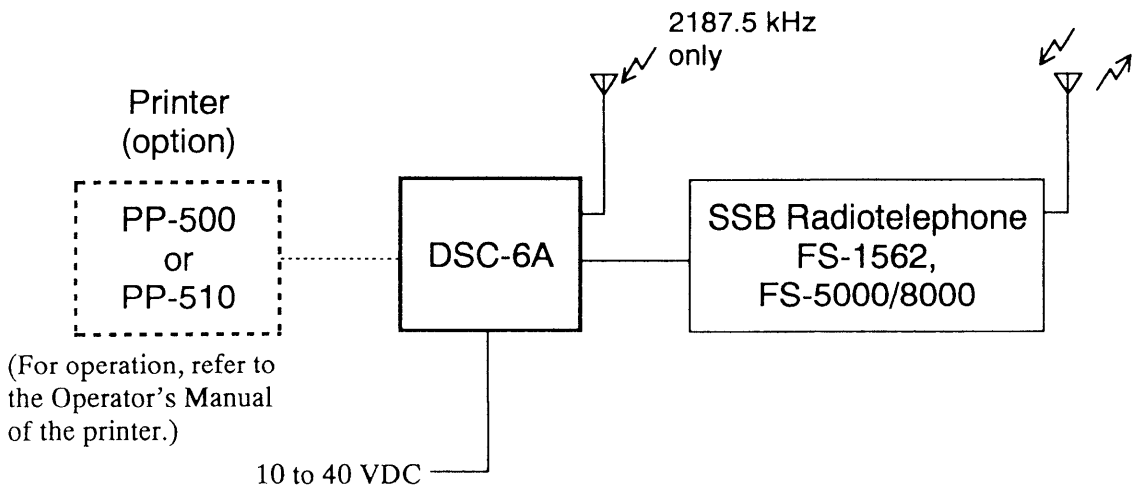

## DSC-6A System (for A2 Area)

# **PART 1 Table of Contents**

(Operation)

	<u>Page</u>
<b>Overview</b> .....	<b>1</b>
General .....	1
DSC Message .....	2
Example of Distress Call .....	2
Example of Individual Call .....	3
Remote Function and Automatic Acknowledge .....	4
Other Calling Categories .....	6
<b>1. Basic Operation</b> .....	<b>1-1</b>
1.1 About the Display .....	1-1
1.2 Preparing and Transmitting Message .....	1-2
1.3 SSB control by DSC-6/6A .....	1-3
1.4 Remarks on SSB Setting .....	1-3
<b>2. Control Description</b> .....	<b>2-1</b>
2.1 Keys .....	2-1
<b>3. Distress Alert Transmission</b> .....	<b>3-1</b>
3.1 Operation Flow from “Distress Transmission” to “Voice Communication” .....	3-1
3.2 Transmitting Distress Alert .....	3-1
3.3 Receiving Distress Acknowledge Signal .....	3-3
3.4 Communicating with Coast Station .....	3-3
<b>4. Transmitting Distress Relay Call</b> .....	<b>4-1</b>
4.1 In case that you receive distress alert on HF band .....	4-1
4.2 Distress Relay Call (on MF/HF) .....	4-3
<b>5. Receiving Distress Alert from Other Ship (on 2187.5 kHz only)</b> .....	<b>5-1</b>
<b>6. Programming Scan Frequencies</b> .....	<b>6-1</b>

<b>7. Manual Entry of Ship's Position and Time</b>	<b>7-1</b>
<b>8. All Ships Call</b>	<b>8-1</b>
8.1 Transmitting "All Ships Call" .....	8-1
8.2 Receiving "All Ships Call" .....	8-4
<b>9. Individual call</b>	<b>9-1</b>
9.1 Transmitting "Individual Call" (ACK RQ) .....	9-1
9.2 Receiving Acknowledge Back (ACK BQ) Signal .....	9-4
9.3 Receiving "Individual Call" (ACK RQ) .....	9-5
<b>10. Preparing and Saving Transmit Messages</b>	<b>10-1</b>
10.1 Preparing and Saving Transmit Messages .....	10-1
10.2 Retrieving and Transmitting a File .....	10-3
<b>11. Transmit/Receive Message Memory</b>	<b>11-1</b>
11.1 Transmit Message Memory .....	11-1
11.2 Receive Message Memory .....	11-3
<b>12. Other Calling Types and Other Functions</b>	<b>12-1</b>
12.1 Other Calling Types .....	12-1
12.2 File Menu .....	12-4
<b>13. Printer Setup (Auto/Manual)</b>	<b>13-1</b>
<b>14. Menu List</b>	<b>14-1</b>
<b>Appendix 1 DSC Frequency Table</b>	<b>AP1-1</b>
<b>Appendix 2 Application</b>	<b>AP2-1</b>
1. Finding Position of Other Station .....	AP2-1
2. Transmitting Own Ship's Position to Other Stations .....	AP2-2
3. Polling .....	AP2-3
4. Telex Operation with the DP-5 .....	AP2-4
5. Test Call .....	AP2-5



# Overview

## General

### What is the DSC-6/6A?

The DSC-6/6A is a Digital Selective Calling Terminal provides distress/safety, and individual calling for coast station or marine vessels.

The DSC-6/6A is connected to the FURUNO SSB Radiotelephone and can control the frequencies and communication mode settings of the radiotelephone by using the "remote control" function. For further details of the remote function, refer to page 4.

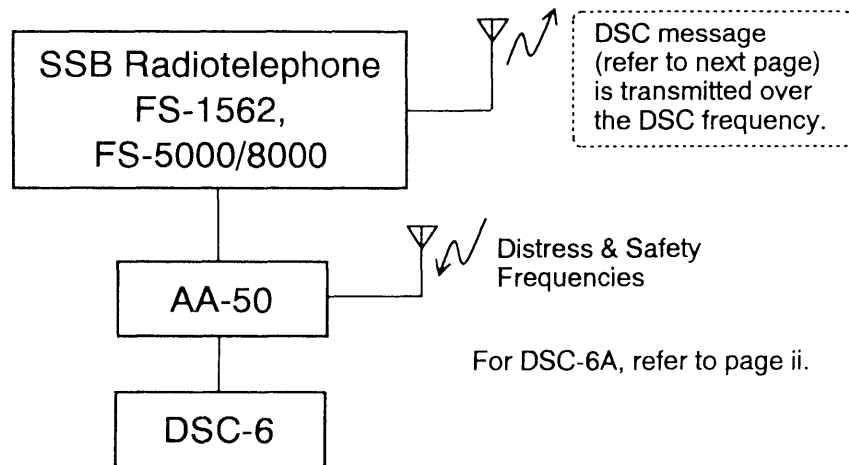

### Receiving a message

When receiving the distress alert or message addressed to own ship, the aural alarm sounds.

### About the aural alarm

When receiving the distress or urgent call, the alarm sounds until the **ALARM STOP** key is pressed. For all other calls, the alarm sounds for five seconds when they are received.

The aural alarm tone depends on message received: The operator can know what type of message is received by listening to the alarm tone.

NOTE: The safety receive alarm frequencies are 2200Hz and 0Hz (interval: 250ms), and the individual receive alarm frequencies are 440Hz and 880Hz (500ms), and the distress warning alarm (five seconds) frequencies are 1300Hz and 0Hz (250ms). Note that these cannot be changed.

### Other functions

Transmitted and received messages can be saved to the memory and printed out (optional printer required) if necessary.

# DSC Message

## Contents

- ① Format specifier (calling category) such as distress, individual
- ② Address (coast ID and other ship ID)
- ③ Category (communication priority)
- ④ Own ship ID
- ⑤ Telecommand (class of emission)
- ⑥ TX and RX working frequencies (frequency data for voice communication with other station after transmission of DSC message) or Ship's co-ordinates

## Example of Distress Call (Refer to page 3-1.)

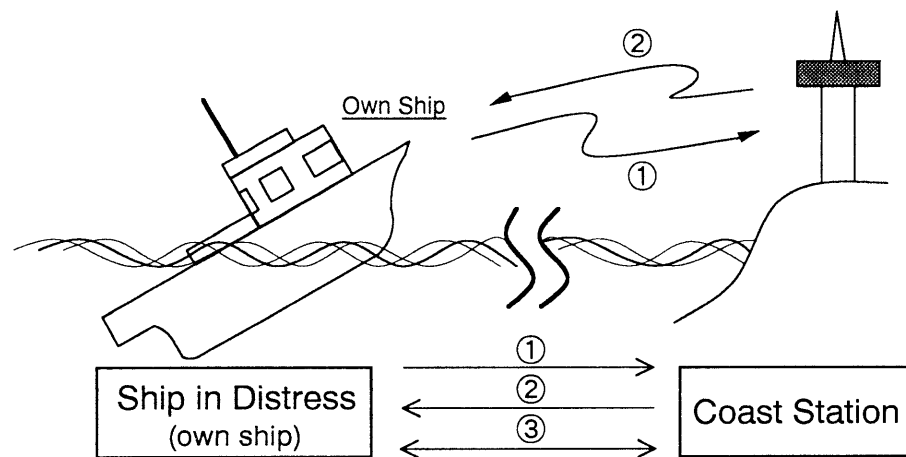

## Procedure

Nature of Distress
[1]: Fire, explosion
[2]: Flooding
[3]: Collision
[4]: Grounding
[5]: Listing, capsizing
[6]: Sinking
[7]: Disabled & adrift
[8]: Abandoning
[0]: Undesignated
[←]: Piracy/armed robbery attack
[→]: Man overboard

- ① Open cover on DISTRESS key and press the key 4 sec. (To announce nature of distress. Press DISTRESS key continuously while pressing appropriate key within 3 sec. Continue pressing DISTRESS key at least 4 sec. After five seconds, the alert is transmitted over TX DSC frequency.
- ② Receive the distress acknowledge (DIST ACK) signal from coast station. (See NOTE.) The aural alarm sounds when DIST ACK is received. Press the **ALARM STOP** key to silence the alarm.
- ③ After receiving the DIST ACK signal, communicate with coast station over working frequencies and class of emission (automatic setting) designated by own ship.

**NOTE:** If the distress call is not acknowledged within 3.5 – 4.5 minutes it is automatically retransmitted.

## Example of Individual Call (Refer to page 9-1.)

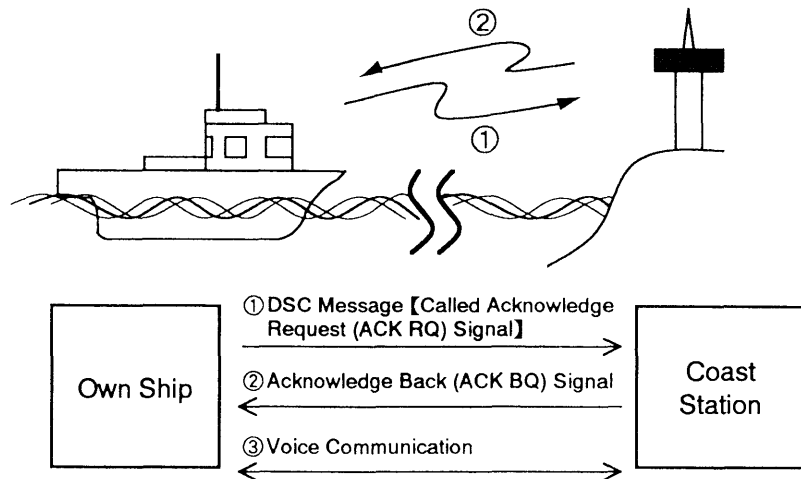

### Procedure

- ① Prepare message then transmit it to coast station (or other ship) by pressing the **CALL** key. (The TX frequency of SSB radiotelephone is automatically changed to DSC frequency and the message is transmitted.)
- ② Receive the acknowledge back (ACK BQ) signal from coast station within five minutes over RX DSC frequency.
- ③ After receiving the ACK BQ signal, communicate with the coast station over working frequencies and class of emission designated by own ship or the coast station.

# Remote Function and Automatic Acknowledge (AUTO ACK)

## General

The DSC-6/6A and FURUNO SSB radiotelephone communicate with each other by means of the MIF (FURUNO Radio Interface) data format, which is a unique handshaking type signal exchange system developed by FURUNO.

## AUTO ACK

The auto acknowledge feature automatically transmits the acknowledge back (ACK BQ) signal when an individual call is received. With the auto acknowledge feature turned on the remote control function is also turned on.

## Remote control function

The remote control function lets the DSC-6/6A set DSC frequencies, working frequencies and class of emission for the radiotelephone.

## Turning remote (& AUTO ACK) on/off

To enable or disable AUTO ACK and remote control, use the **2** key. Each press of the key enables/disables auto acknowledge and remote control function in the sequence shown below.

**Note:** *The AUTO ACK function is not available when receiving or relaying the distress alert, or ECC (Error Check Character) error is received. (ECC error appears at the end of a receive message when an error is detected in the message.)*

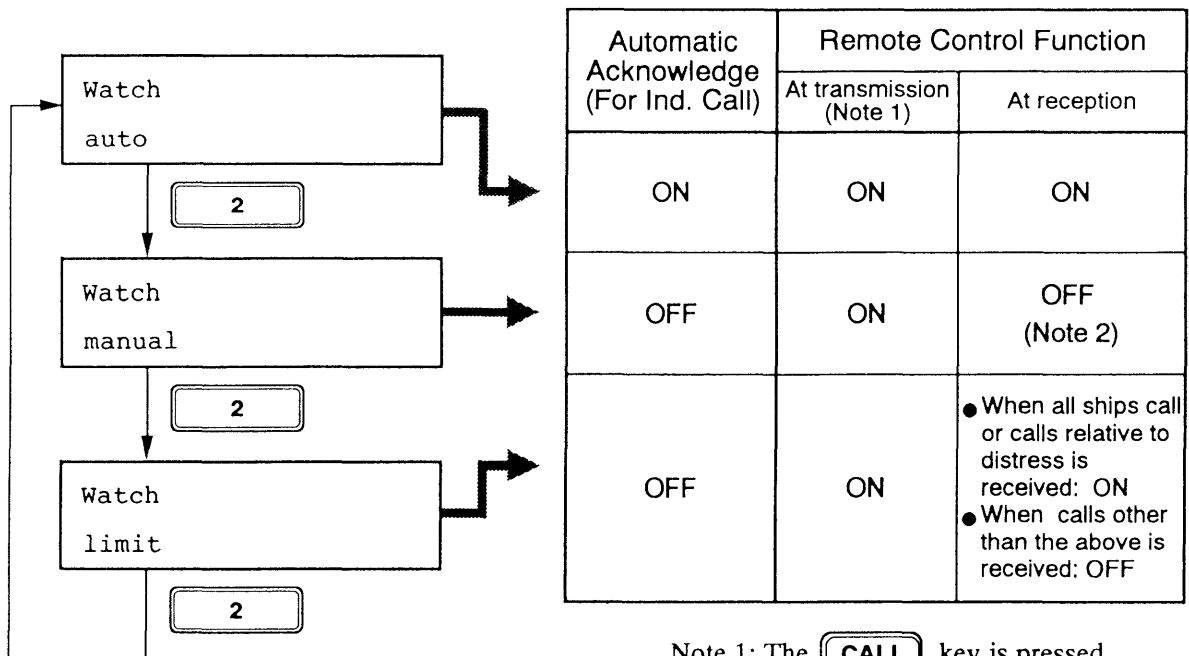

Note 1: The **CALL** key is pressed.

Note 2: When all ship call is received, press **2** key to turn remote function on, causing working frequency to be automatically set.

## LIMIT FUNCTION

The limit setting provides restricted use of the remote control function. It is useful when the following situations occur at the same time.

1. Automatically sets working frequencies when an all ship's call is received, so as **not to miss initial voice** from the transmitting station.
2. Prevents automatic transmission of the acknowledge back (ACK BQ) signal, in response to an individual call, **when no operator is present.**
3. Prevents automatic transmission of **own ship's position data,** in response to a position request call.

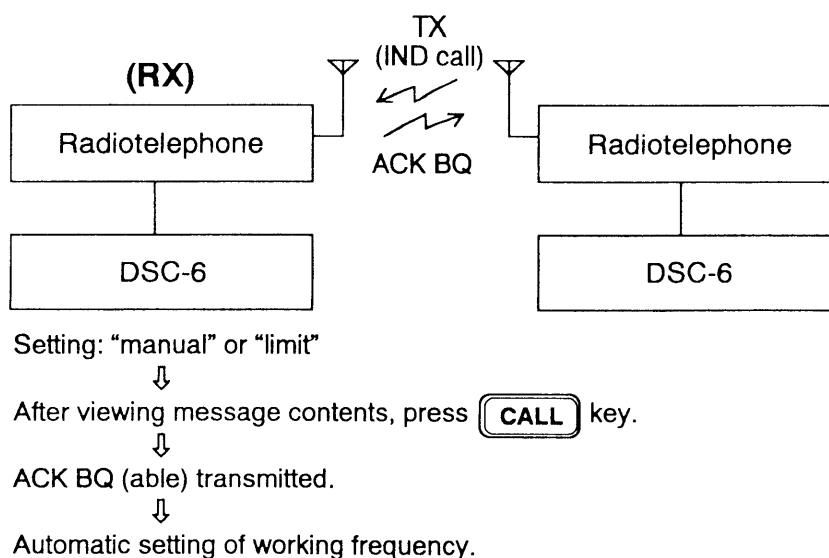
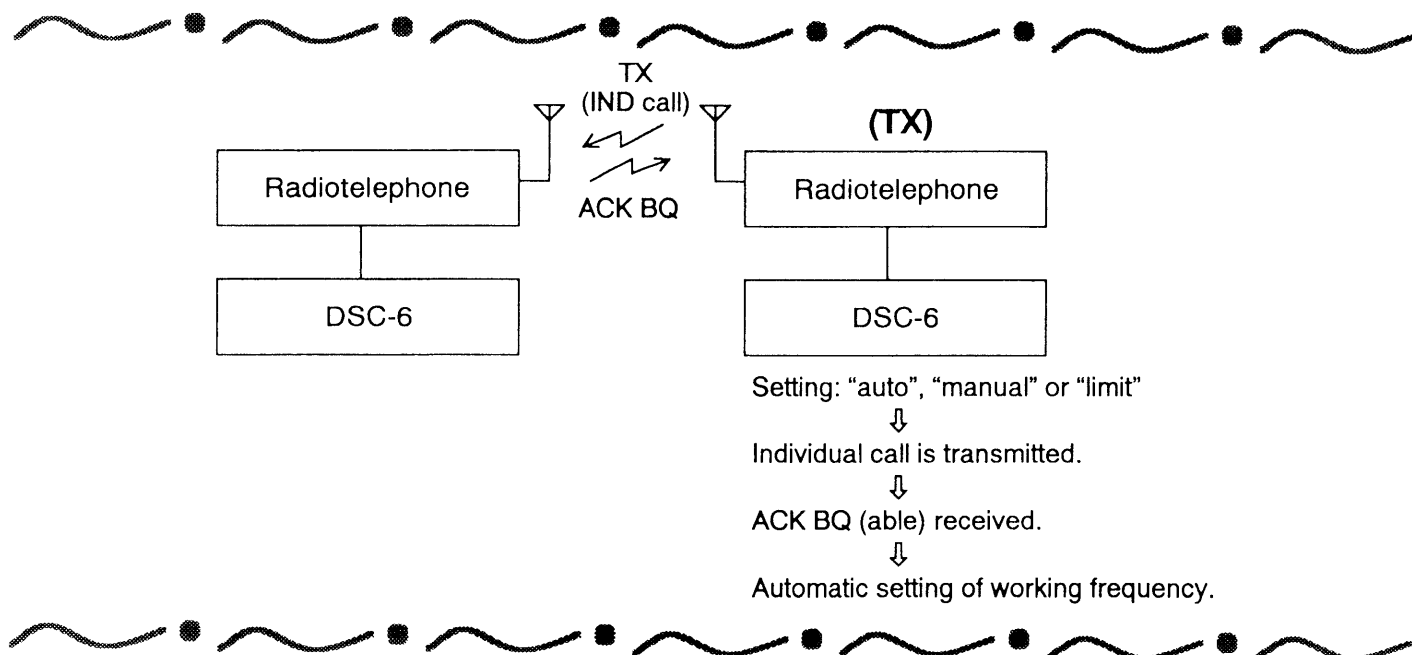

### Example of AUTO ACK

#### Individual call transmitted by own ship's DSC-6 ①

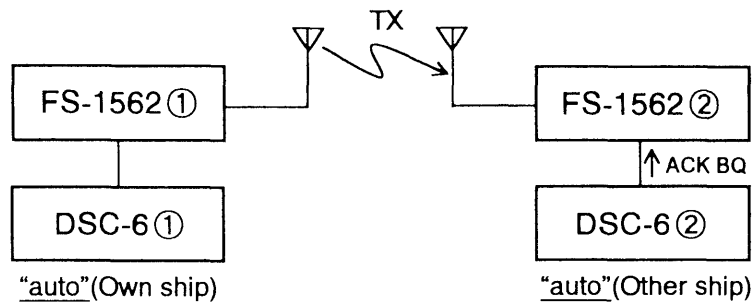

Operation at DSC-6	Frequency of FS-1562 ① (automatic setting)	Frequency of FS-1562 ② (automatic setting)
1. Press <b>CALL</b> key of DSC-6 ①.	Changed to TX DSC frequency. (Message is transmitted.)	
2. DSC-6 ② receives message through FS-1562 ②. (Alarm sounds.)		
3. DSC-6 ② sends ACK BQ automatically.		Changed to TX DSC frequency. (ACK BQ is transmitted.) After that, changed to working frequencies and class of emission designated by DSC-6 ①.
4. DSC-6 ① receives ACK BQ through FS-1562 ①. (Alarm sounds.)	Changed to working frequencies and class of emission designated by DSC-6 ①.	

Then, voice communication begins between stations .

## Other Calling Categories (Types)

### General

The DSC-6/6A provides the following types of calls, as well as distress and individual calls previously mentioned.

- Distress Relay (Refer to page 4-1.)
- All Ships (Refer to page 8-1.)
- Group (For specific group ships)
- Geographic Area (For ships within specific range)
- Telephone (PSTN call)
- Test call

Further, the “Polling” and “Position Request” functions are also available. Refer to Appendix 2.

# 1. Basic Operation

## 1.1 About the Display

### Normal display

When the DSC-6/6A is turned on, the following display appears. This display is known as the “normal display.”

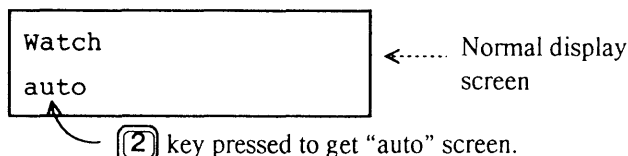

Should you get lost in operation you can return to the normal display by pressing the **CANCEL** key several times.

### Selecting and registering items

The arrow keys ( **◀** and **▶** ) function to select items on the LCD. After selecting item, press the **ENT** key to register it.

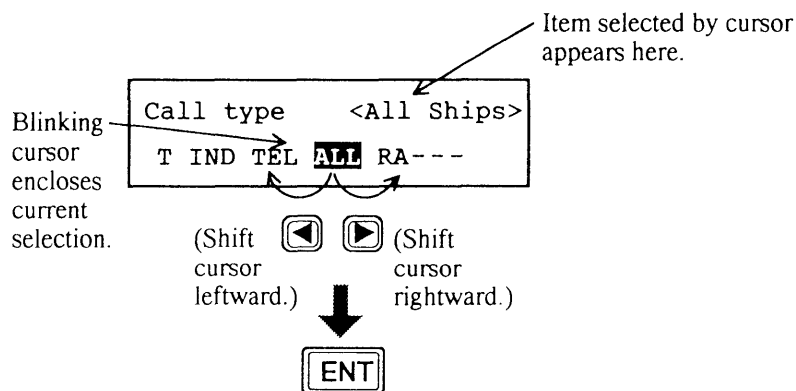

### When blinking question mark appears

Press the **ENT** or **SELECT** key depending on your desire.

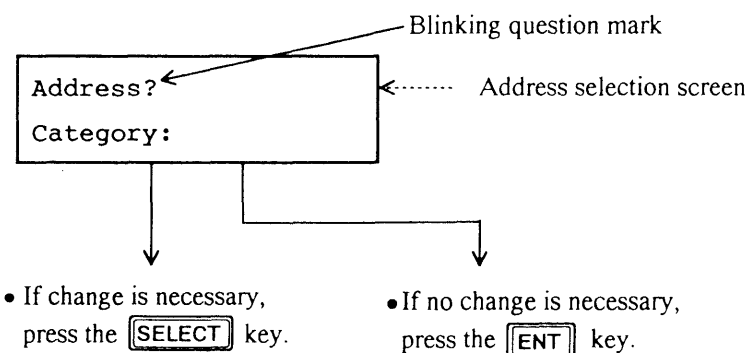

## 1.2 Preparing and Transmitting Messages

### Methods

There are two methods by which you can prepare and transmit messages, and they are shown below.

#### Preparing message for immediate transmission

Prepare message and then transmit it.

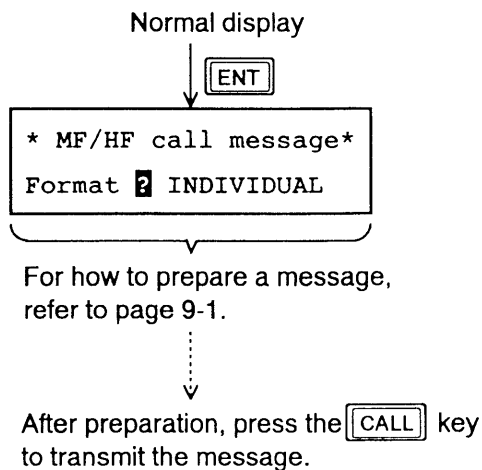

#### Preparing and storing message for later transmission

Prepare messages excluding distress message and save them to the memory (Maximum 99 files). You may retrieve and transmit a memory-stored message as follows.

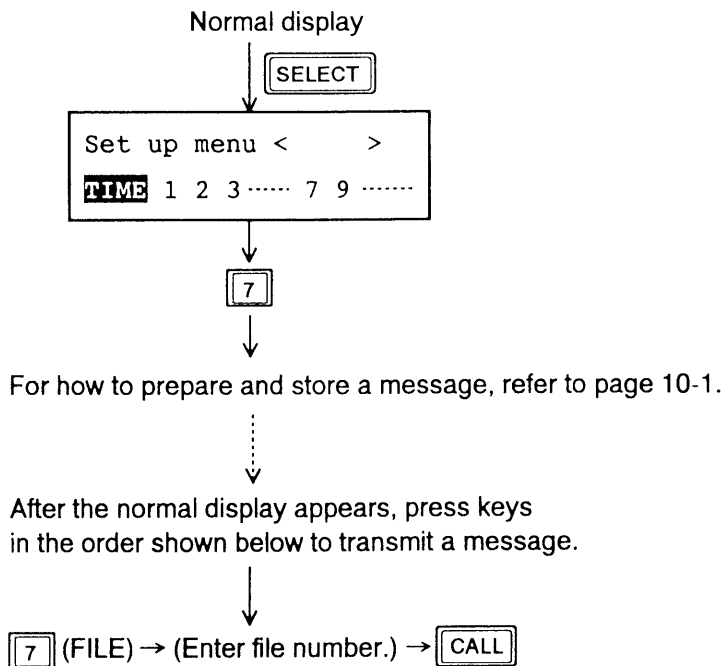



## 1.3 SSB Control by DSC-6/6A

**SSB output power at distress alert transmission** When the distress alert is transmitted (by pressing the **DISTRESS** key), the output power of the SSB radiotelephone is automatically set to **maximum**.

**When SSB becomes inoperative** The SSB radiotelephone keyboard **accepts no key input** while DSC message is transmitted. (Distress call: inoperative about 40 seconds, other calls: inoperative about 8 seconds.) It is also disable until the acknowledge back (ACK BQ) signal is received. To unlock it manually, if necessary, press the **CANCEL** key.

## 1.4 Remarks on SSB Setting

When the frequency of the FURUNO radiotelephone is set to 2182 kHz, the following operations are not available.

1. Scan (page 2-2 in PART 1)
2. General calling other than distress (page 4-1 in PART 2)

# 2. Control Description

## 2.1 Keys

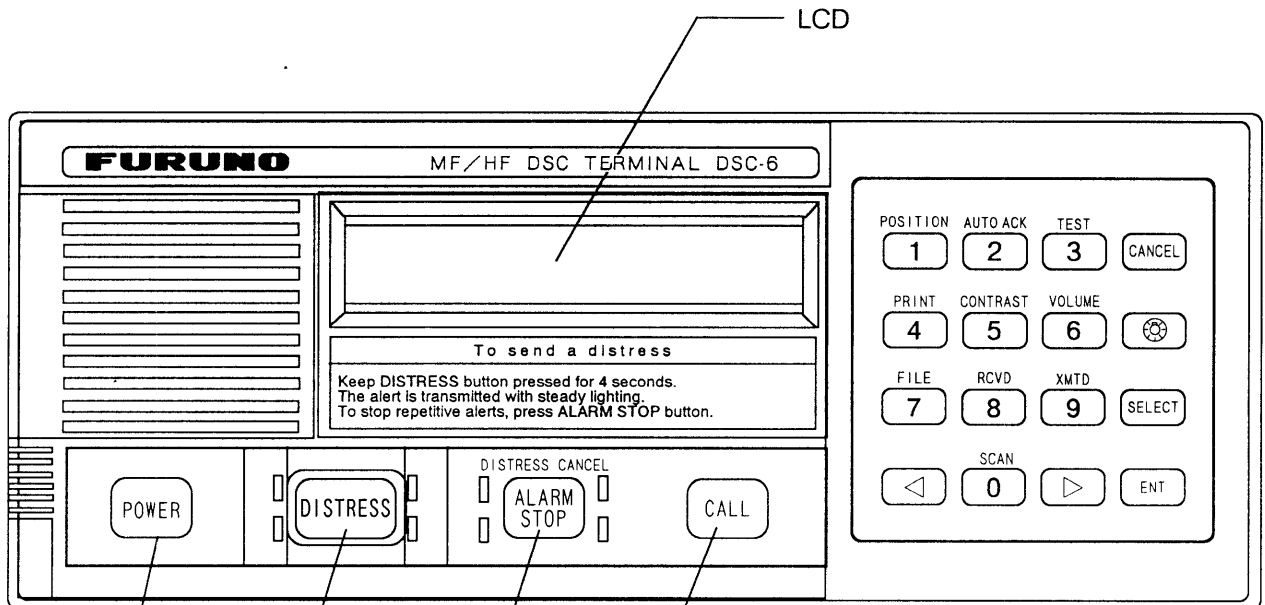

**CALL** : Transmits messages other than distress.

(DISTRESS CANCEL)

**ALARM STOP**

: Silences the receive alarm.  
Stops repetitive alerts.

**DISTRESS** : Transmits the distress alert.  
(Press the key 4 sec continuously.)

**POWER** : Turns power on and off. To turn the power off, press and hold down the switch at least two seconds. Then, release the key after a loud beep is heard.



















### About LED



The four LEDs (Red) blink when the **DISTRESS** key is pressed, and light continuously when the distress alert is completely transmitted.



- Upper two LEDs (Red) blink when distress or urgent message is received.
- Lower two LEDs (Green) blink when messages other than distress/urgent are received.

Key	Function/Purpose
 ~ 	Enter numeric data.
	Cancels wrong data and restores previous menu.
	Adjusts illumination of LCD, switches and keys in four levels.
	1. Displays "Set up menu" (Main menu). (Refer to pages 9-6, 10-1, 13-1 for "Setup menu".) 2. Changes settings of items appearing with blinking question mark.
	Registers key input. (Blinking item is registered when key is pressed.)
	1. Shifts the cursor leftward. 2. Restores previous item when pressed at displays with a blinking question mark.
	Shifts the cursor rightward.
POSITION 	Ship's position and time are shown while pressed and held down.
AUTO ACK 	Turns transceiver remote and automatic transmission of acknowledge call (AUTO ACK) on or off. (Refer to page 4.) Note that distress alert cannot be automatically acknowledged by "auto acknowledge" function.
TEST 	Conducts self-test. (Refer to PART 2.)
PRINT 	Printing. (This is also available for automatic setting of the printer.)
CONTRAST 	Adjusts contrast of LCD in eight levels.
VOLUME 	Adjusts volume of speaker in eight levels. (Distress and urgency alarms always sound at maximum volume.)
FILE 	Retrieves files.
RCVD 	Displays contents of received messages (Storage capacity: 100 files, 50 each of distress and other). (Refer to page 11-3.)
XMTD 	Displays contents of transmitted messages (Storage capacity: 50 files). (Refer to page 11-1.)
SCAN 	Starts and stops frequency scanning. (If SSB frequency is set to 2182 kHz, scan function is not operated.)

# 3. Distress Alert Transmission

## 3.1 Operation Flow from “Distress Transmission” to “Voice Communication”

### General

For GMDSS vessels, the distress alert must be transmitted by the DSC Terminal. Then, distress voice communications with a coast station is started through the radiotelephone.

The figure which follows shows the operation flow from distress transmission to voice communications.

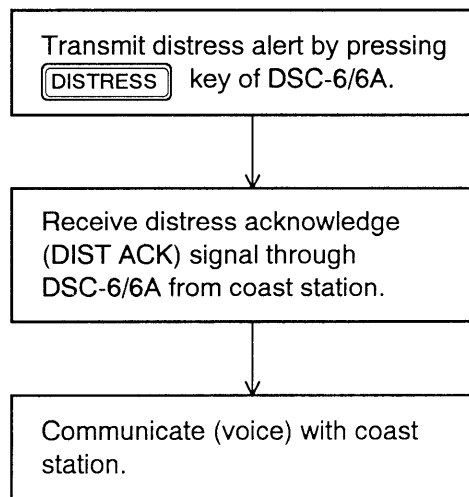

## 3.2 Transmitting Distress Alert

### Procedure

Follow the procedure shown on the next page to transmit the distress alert. When the **DISTRESS** key is pressed, the four LEDs (Red) near this key light continuously.

**Transmitting the distress call**

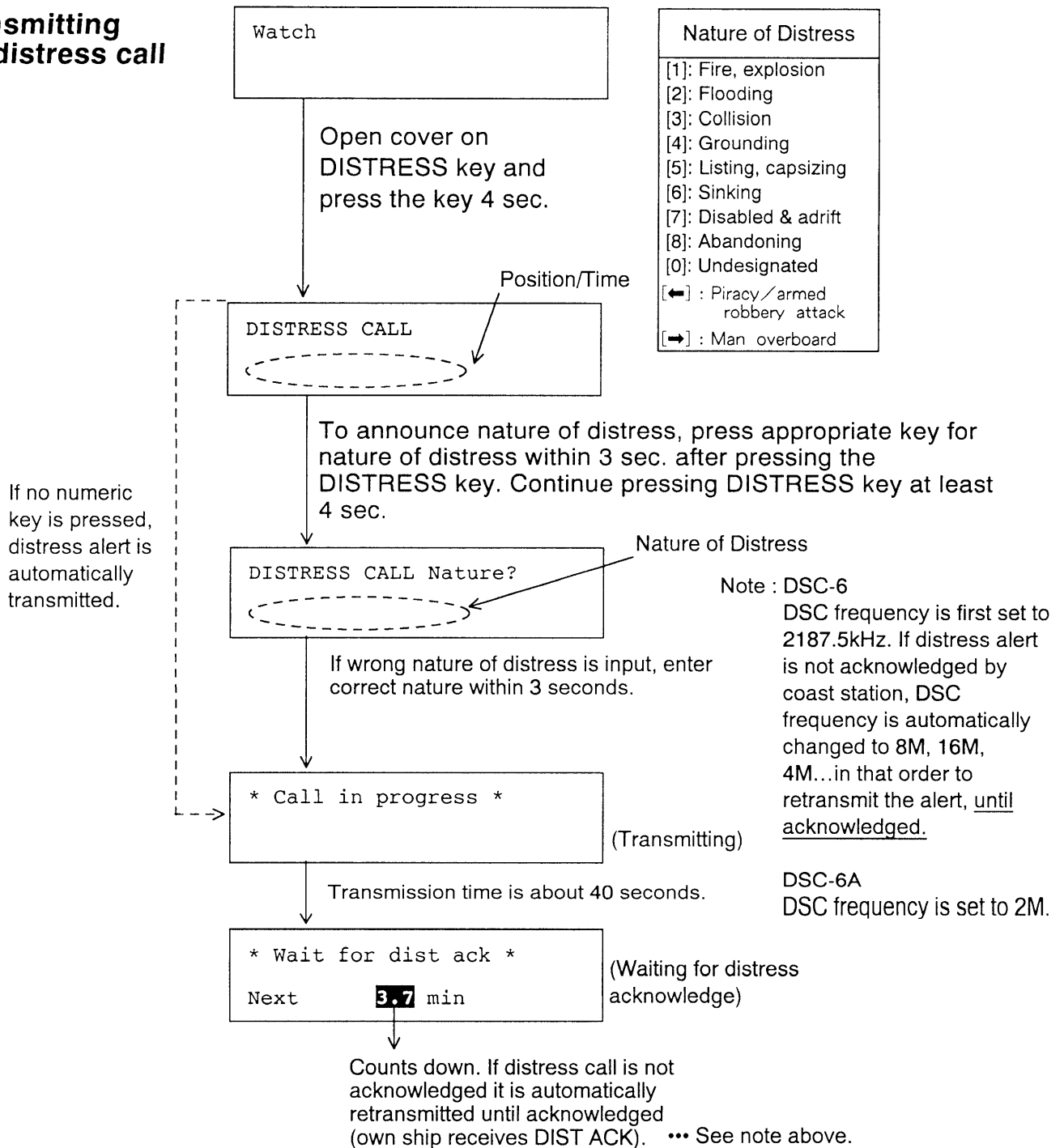

**No automatic input of position data by nav. device**

The ship's position data from a navigational device is usually automatically input to the DSC-6/6A. When the navigation device fails or automatic input is off, however, enter position manually. The procedure for manual entry of position appears on page 7-1.

When your vessel is in distress and there is no automatic input of position, enter it manually (if you are not pressed for time) then press the **DISTRESS** key.

## 3.3 Receiving Distress Acknowledge Signal

### Procedure

After transmitting the distress alert the “Wait for dist ack” display appears. Then, you should receive the distress acknowledge (hereafter referred to as “DIST ACK”) signal from a coast station. The procedure for receiving DIST ACK is as shown below.

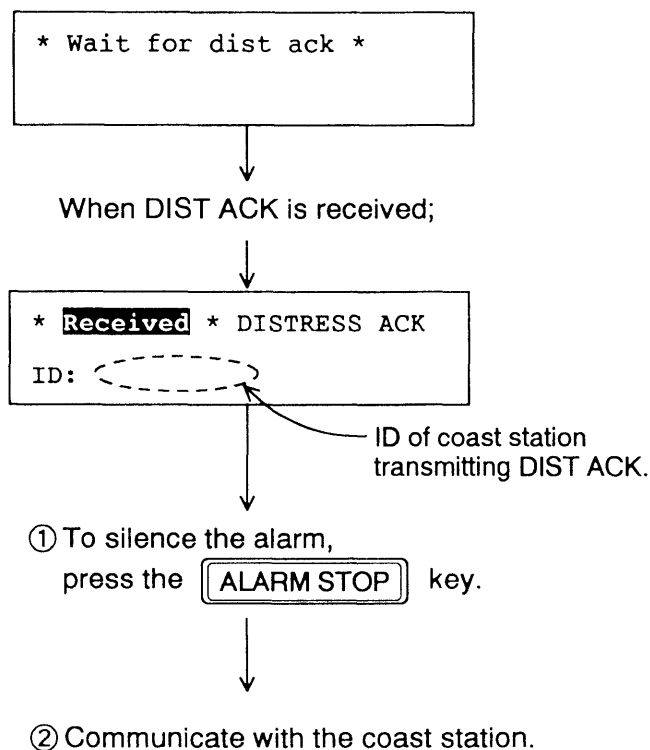

## 3.4 Communicating with Coast Station

### Overview

Since the SSB radiotelephone is automatically set to working frequencies and class of emission, you are now ready to begin voice communications with the coast station.

# 4. Transmitting Distress Relay Call

## 4.1 In case that you receive distress alert on HF band

### General

When you receive the distress alert the audible alarm sounds and the DISTRESS CALL screen appears. If the call is not acknowledged by a coast station **within 3 min.** relay it (to a coast station) as follows.

### Procedure

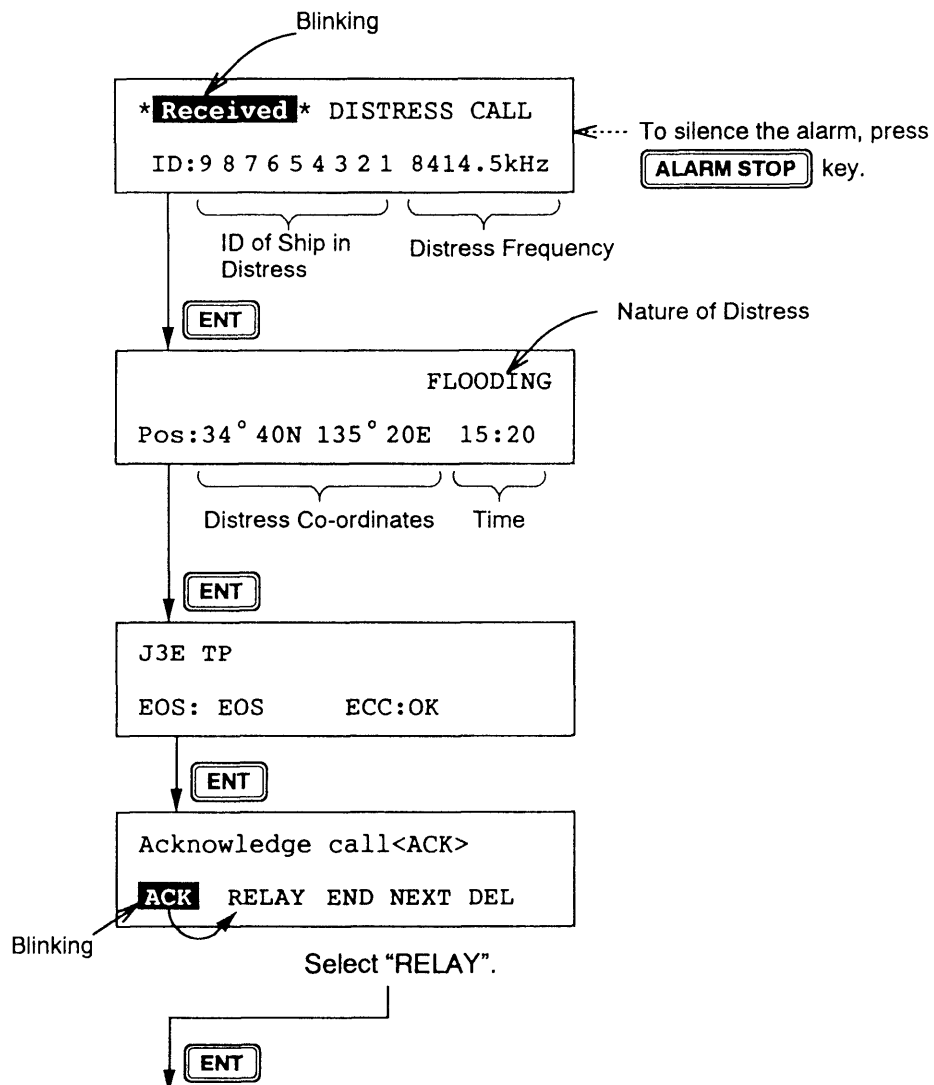

(continued on next page)

RELAY: Relay for all ships.  
 END: Returns to default display.  
 NEXT: Recalls received message.  
 DEL: Deletes received message from file.

4.1 You receive distress alert

(from previous page)

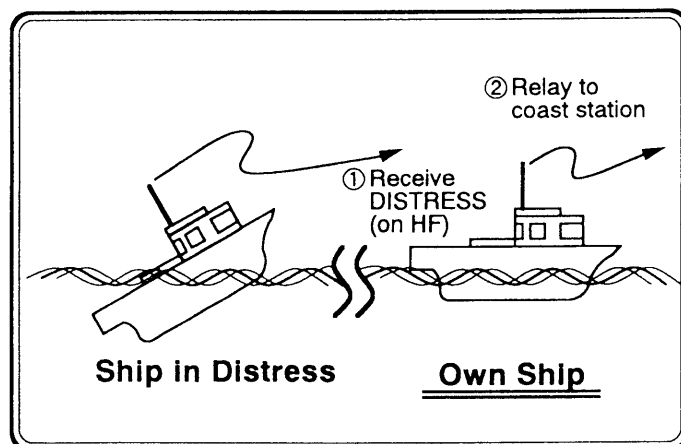
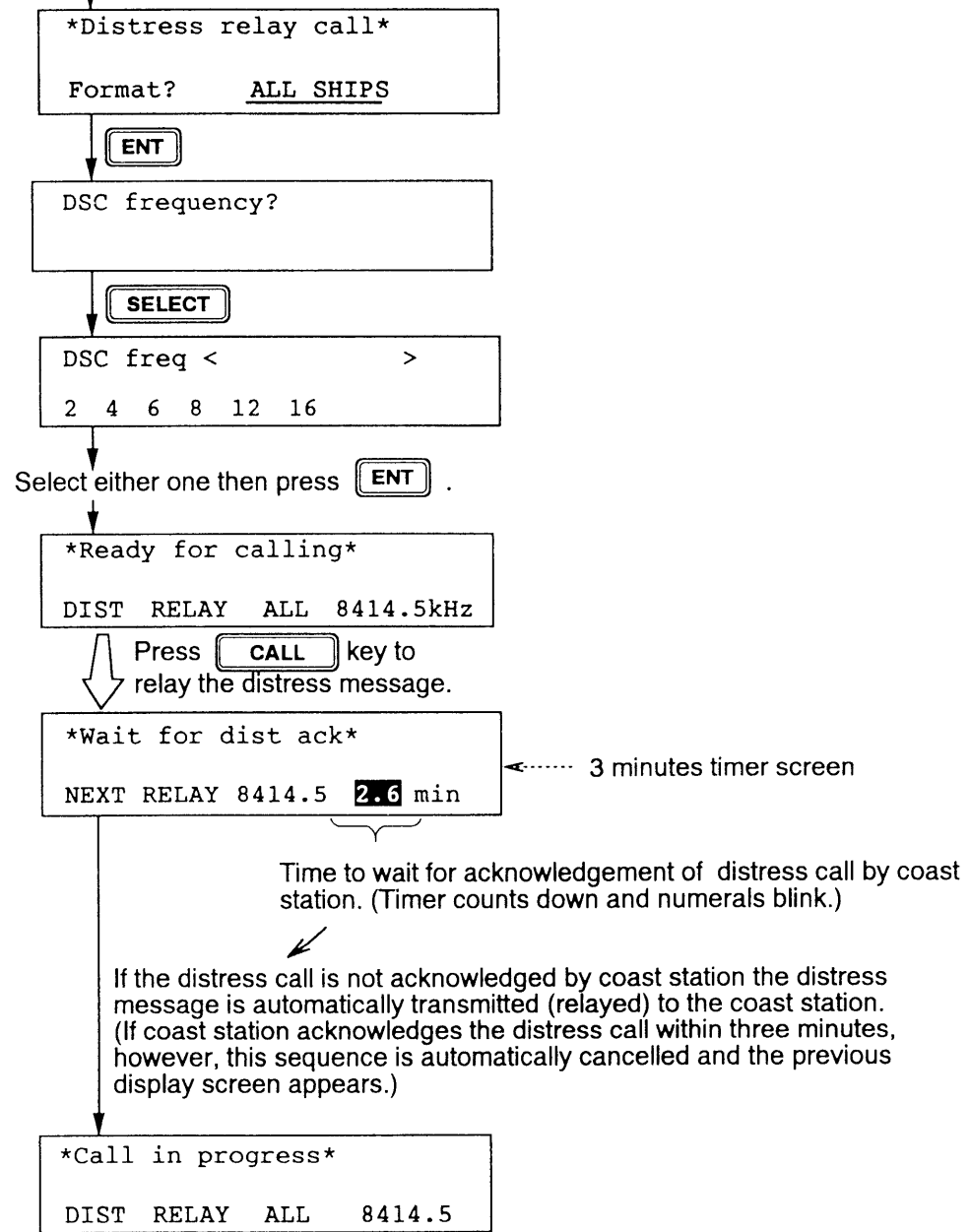



## 4.2 Distress Relay Call on MF/HF

You can relay (transmit) distress alert immediately to coast station in behalf of ship in distress which is not able to transmit the alert by itself.

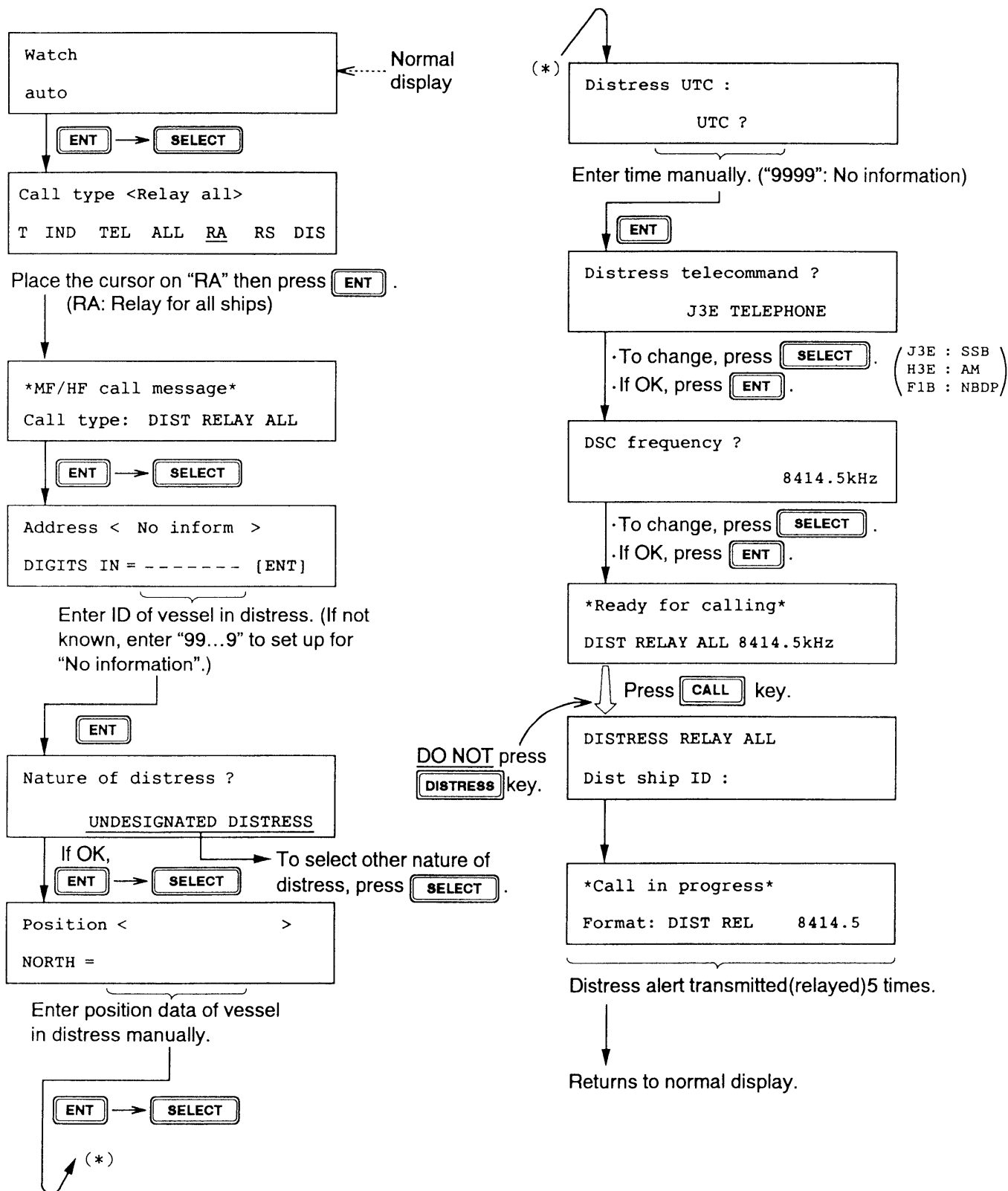

# 5. Receiving Distress Alert from Other Ship (on 2187.5kHz only)

## General

When the DSC-6/6A receives a distress alert from other vessel the two LEDs (Red) near the **ALARM STOP** key blink and the DSC-6/6A sounds the distress alarm. Silence the alarm by pressing the **ALARM STOP** key. Wait for **three minutes** to receive the DIST ACK signal from a coast station. Be prepared to follow the instructions of the coast station. If you do not receive the DIST ACK signal, follow the flow chart shown on the next page.

The DIST ACK signal can be transmitted by you **under certain conditions**. Please carefully read and follow the flow chart to determine whether you should transmit it or not. If you do transmit it, you must **relay the distress alert to a coast station and begin search and rescue operations for the vessel in distress**.

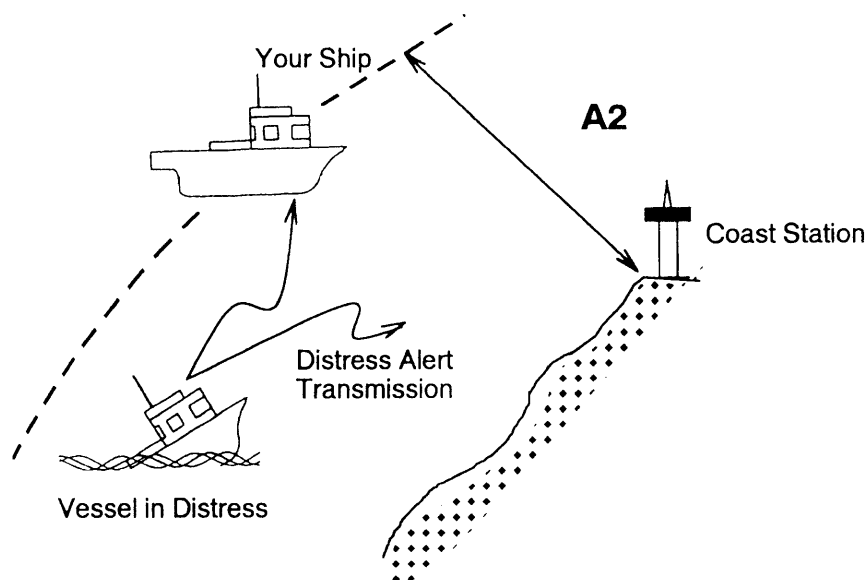

**Flow chart**  
**(Should I transmit**  
**DIST ACK signal**  
**or not?)**

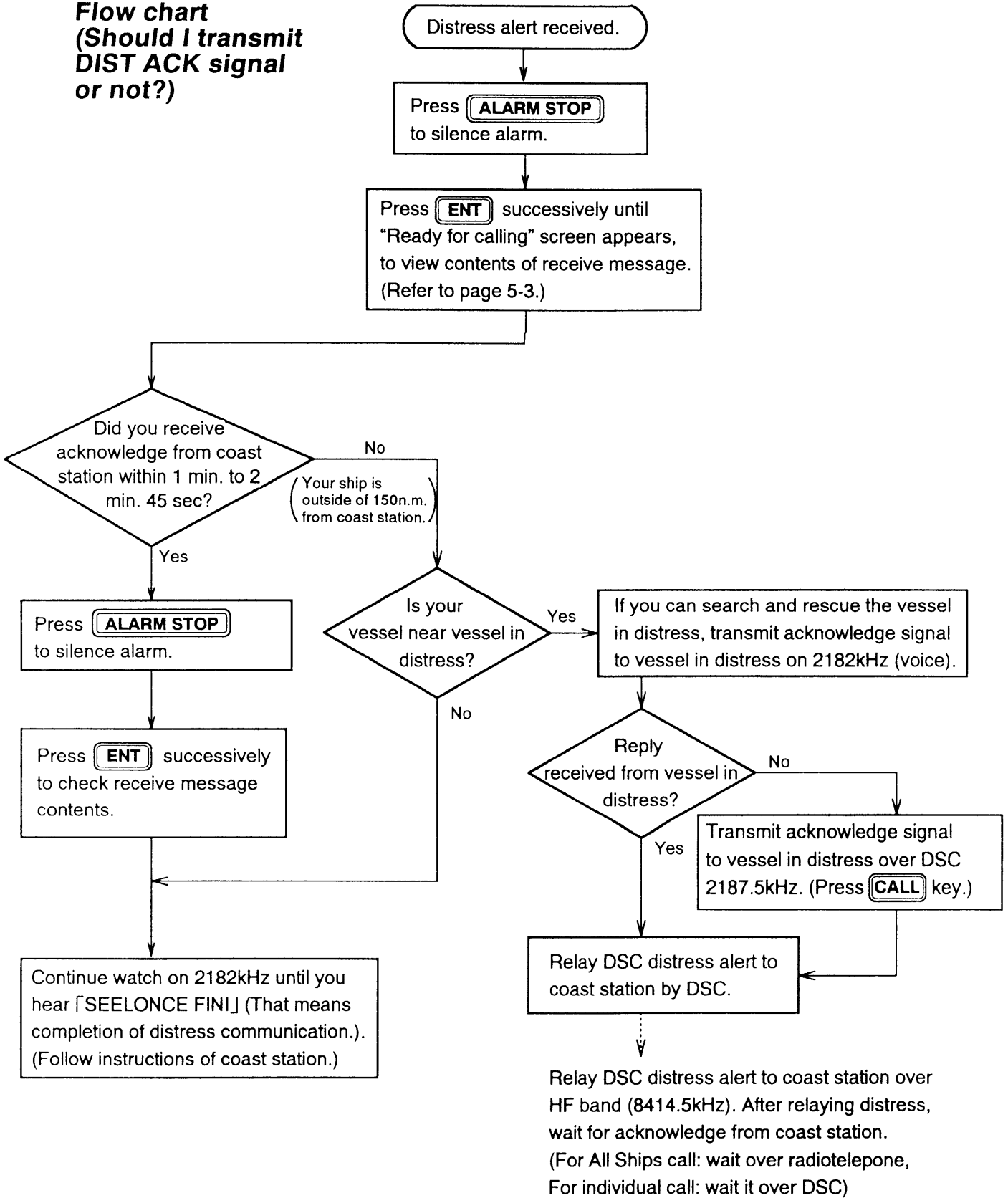

## Transmitting DIST ACK

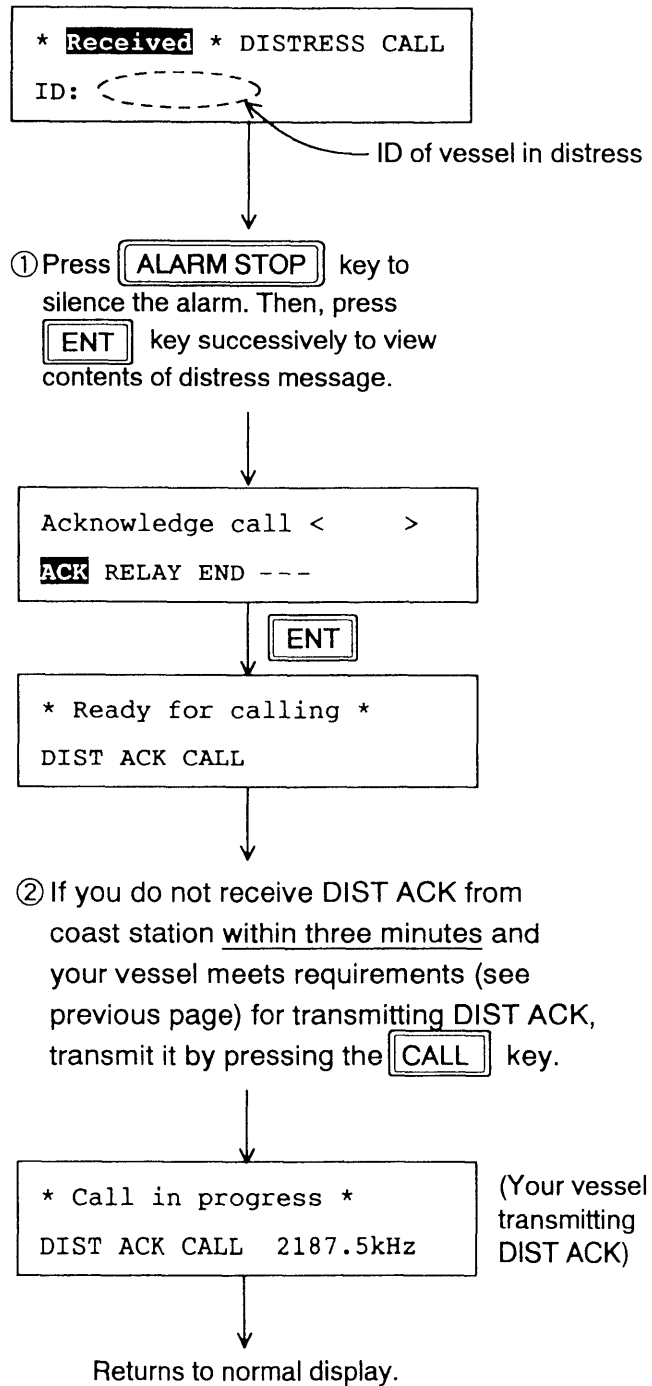

## After transmitting DIST ACK

Begin search and rescue operations for the vessel in distress, communicating with the vessel over 2182kHz (automatically set). Relay distress alert to coast station on HF band. Finally, follow instructions of the coast station.

# 6. Programming Scan Frequencies

At the normal display, press **SELECT** and **0** to get scan set up screen.

Six general DSC frequencies (F1 to F6) can be programmed. (Refer to DSC frequency table on page AP1-1.)

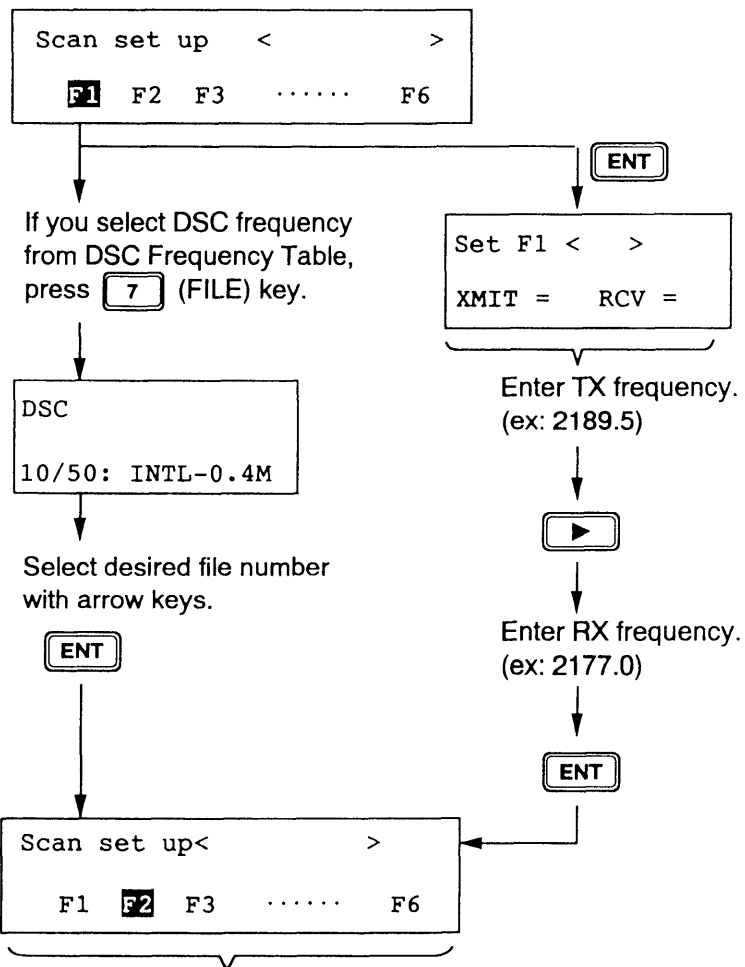

Enter DSC frequency into F2 in the same manner as above.

After completion of programming, press **CANCEL** twice to return to normal display.

Note: To cancel scan frequency, set the RX frequency as 99999.9.

# 7. Manual Entry of Ship's Position and Time

## Entering data manually

If there is no automatic input of position and time data by a navigational device, enter them as follows.

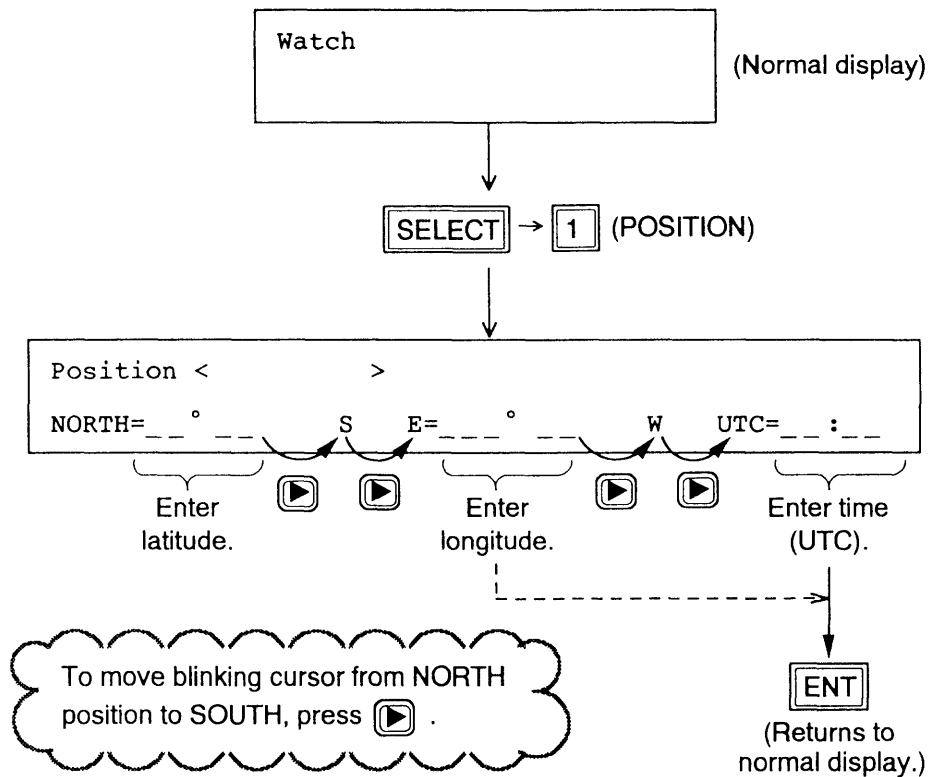

## Remarks after entering data

Once the ship's position and time data are entered manually, automatic input of them is not possible for 12 hours after they are manually entered, even if automatic input becomes available. (Note that manually entered data are automatically erased 12 hours after entry.)

## Cancelling manually entered data

To cancel the manually entered data, enter 9999 for the time.

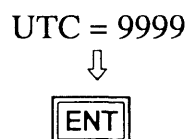

# 8. All Ships Call

## 8.1 Transmitting “All Ships Call”

### General

When an urgent but not life endangering situation arises on your vessel, for example, engine trouble occurs, transmit an all ships call to request assistance.

After transmitting message, you can communicate by voice over the SSB radiotelephone.

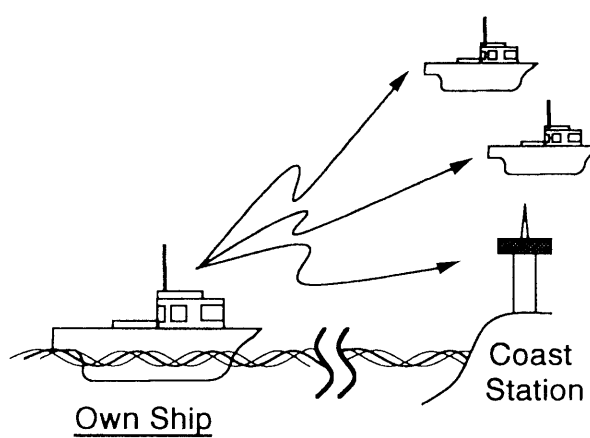

### Procedure

#### Basic procedure

1. Selection of Format specifier
2. Selection of Category (Communication priority)
3. Selection of Telecommand 1 (Class of emission)
4. Entry of Working frequency
5. Entry of DSC frequency
6. Press of **CALL** key

For detailed transmission procedure, see the next page.





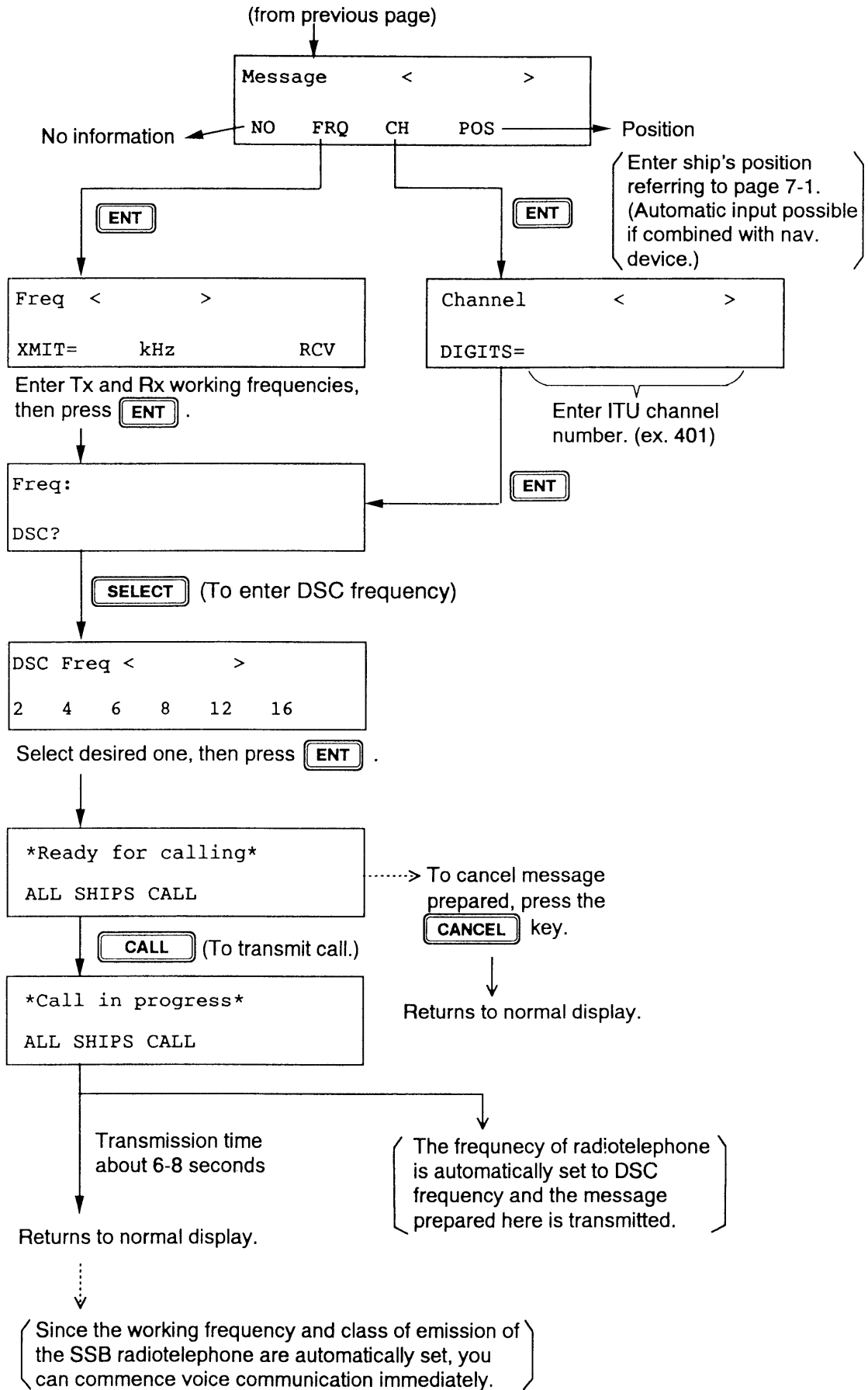

## 8.2 Receiving "All Ships Call"

### General

Remote function of the DSC-6/6A is normally set to either "auto" or "limit" by pressing the **[2]** key, depending on situation. (See page 4.) When receiving an all ships call, therefore, the working frequency and class of emission of the radiotelephone are automatically set to ones designated by a transmitting station, enabling you to watch initial voice from the transmitting station at once.

### Procedure

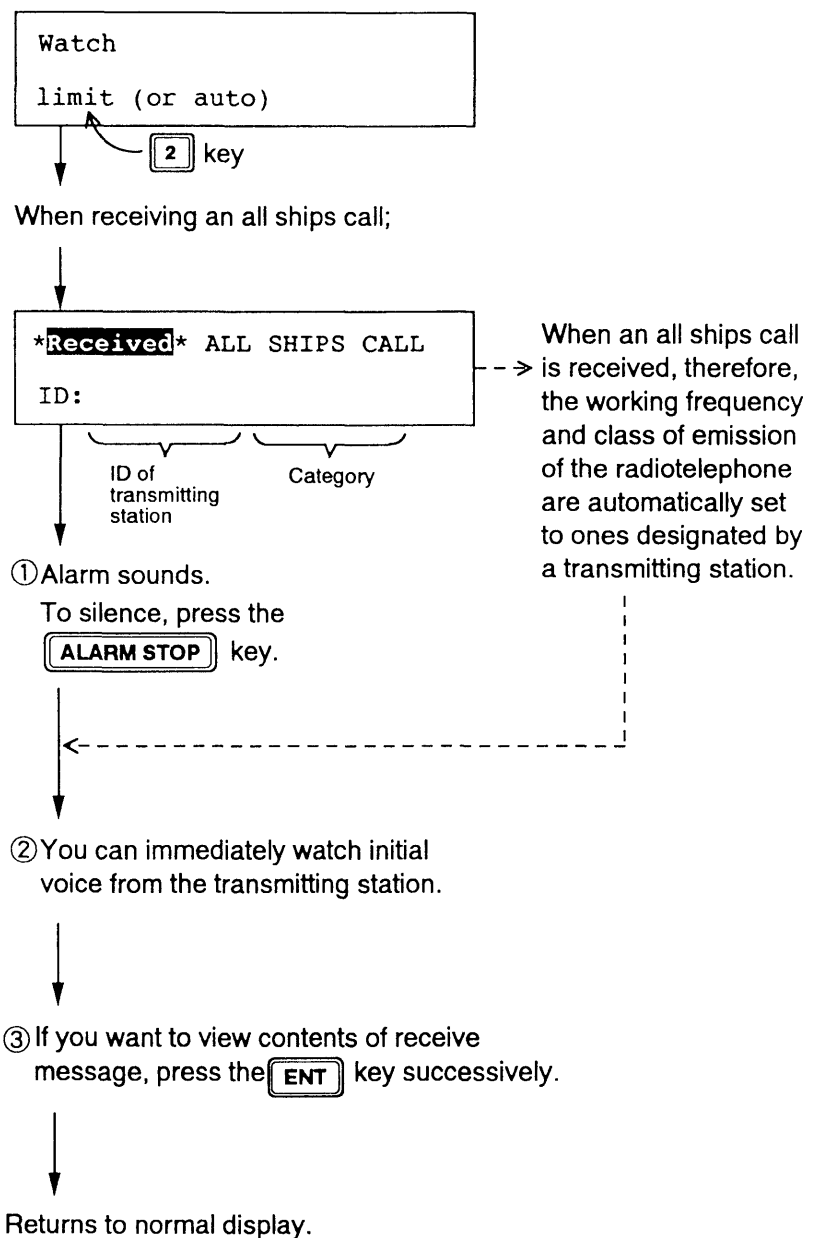

**When remote control is off**

With the remote control function of the DSC-6/6A turned off (manual setting), when you receive "All ships call" while you communicate (voice) with other station, terminate voice communication at once and press the  (AUTO ACK) key, resulting in automatic setting of working frequency for radiotelephone. Then you can hear voice from the transmitting station.

# 9. Individual Call

## 9.1 Transmitting "Individual Call" (ACK RQ)

### General

The individual call is for sending message to a specific station. After transmitting message (called ACK RQ transmission), wait to receive the acknowledge back (ACK BQ) signal from receiving station. You should receive it within five minutes.

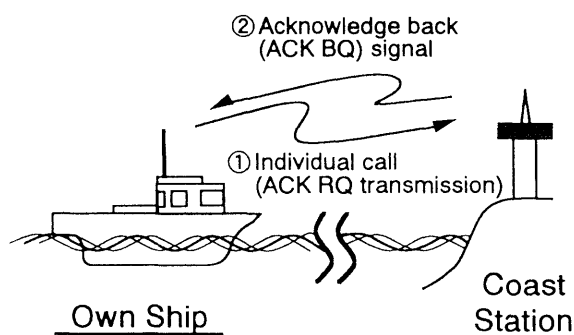

### Procedure

#### Basic procedure

1. Selection of Format specifier (Calling type)
2. Entry of Other ship's ID number or coast's ID
3. Selection of Category (Communication priority)
4. Selection of Class of emission
5. Entry of Working frequency
6. Entry of DSC frequency
7. Press of **CALL** key

#### Detailed procedure

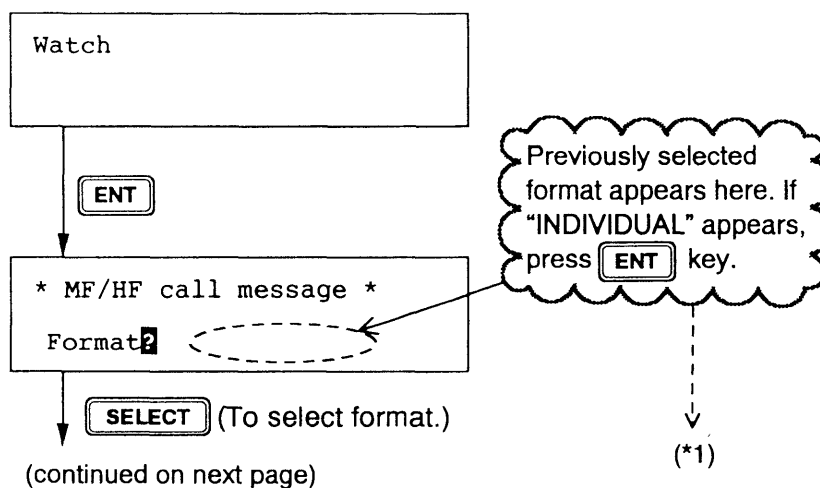

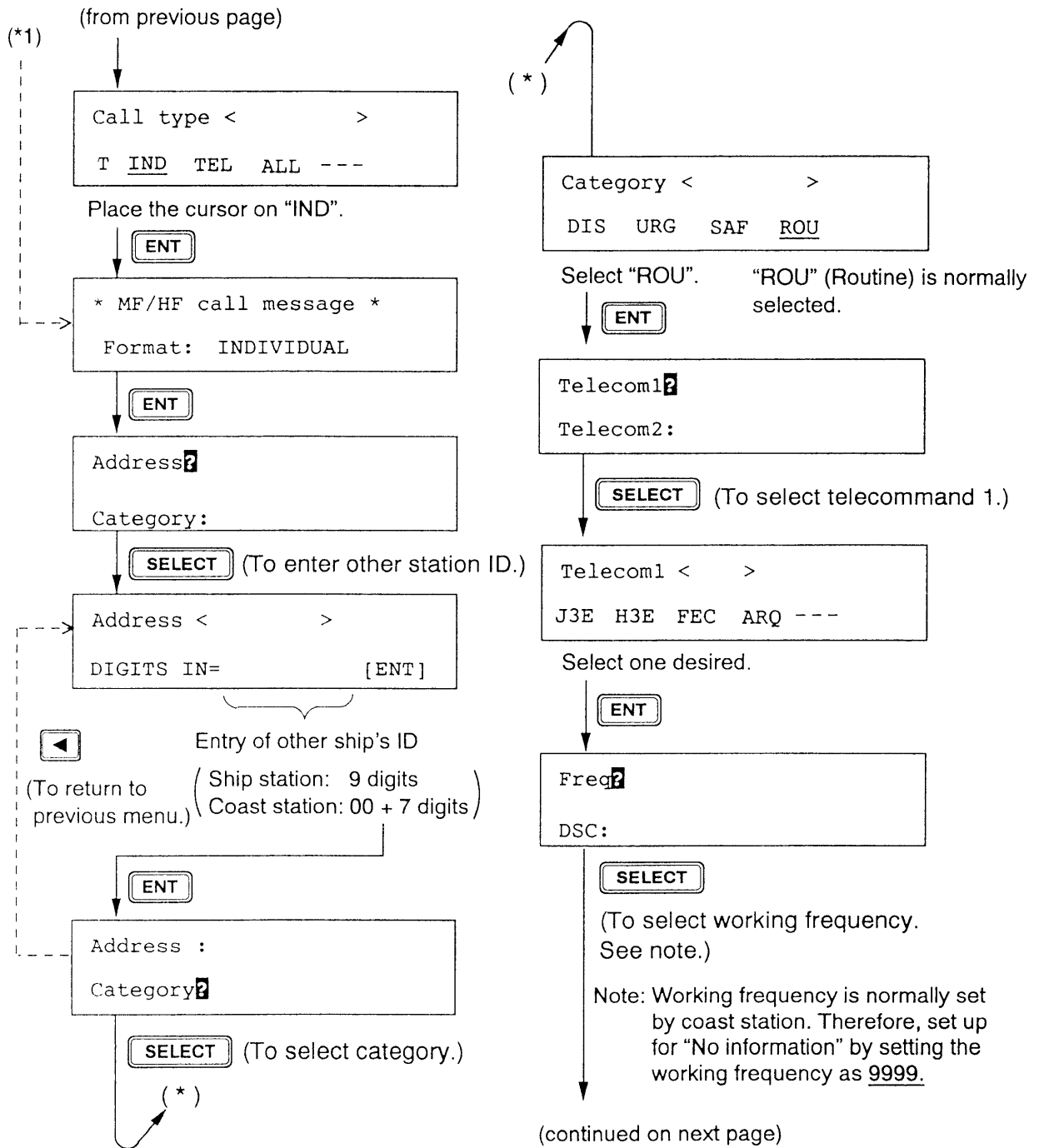

## 9.1 Transmitting "Individual Call"

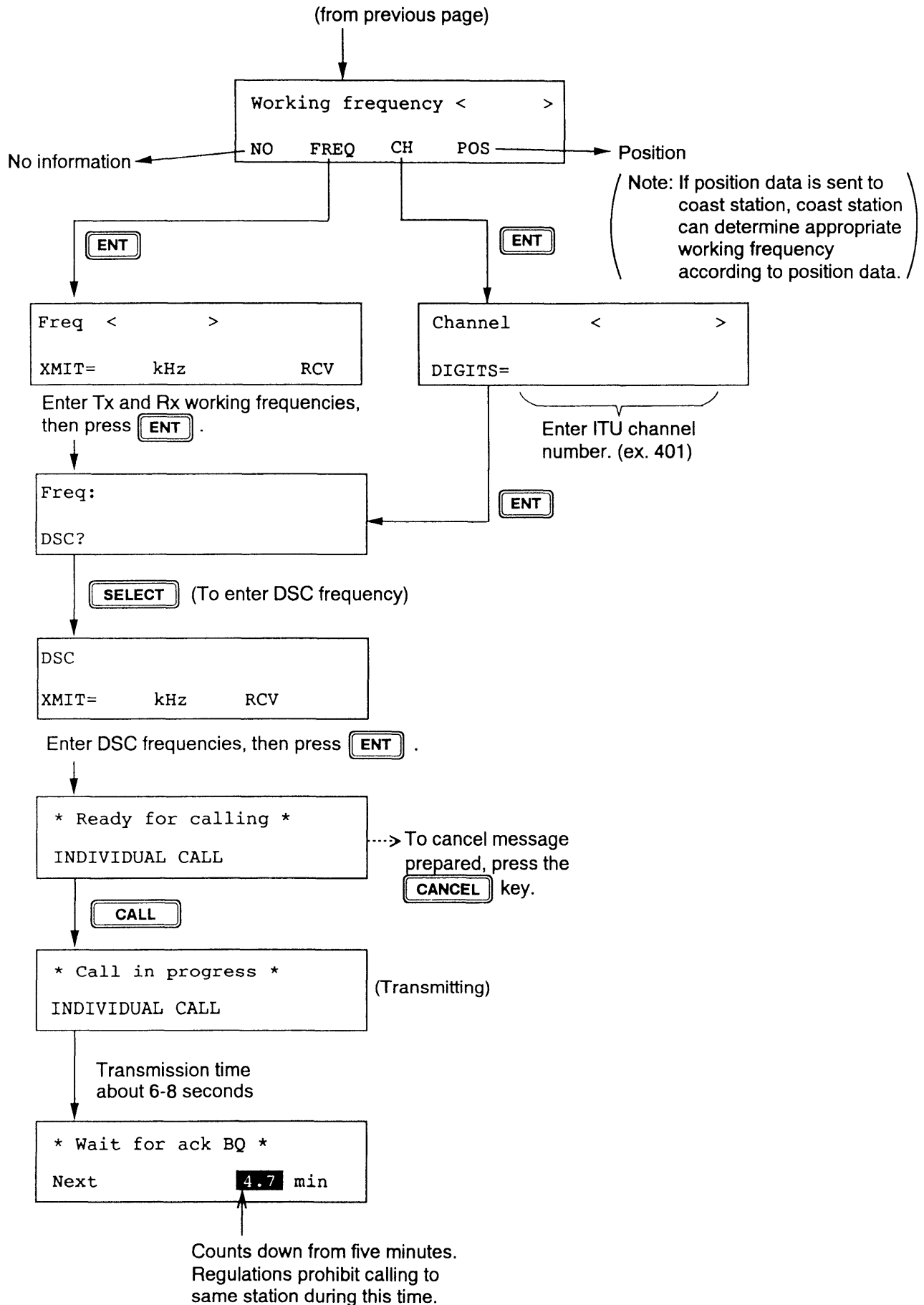

## 9.2 Receiving Acknowledge Back (ACK BQ) Signal

### General

After transmitting an individual call, receive the ACK BQ signal from the receiving station.

### Procedure

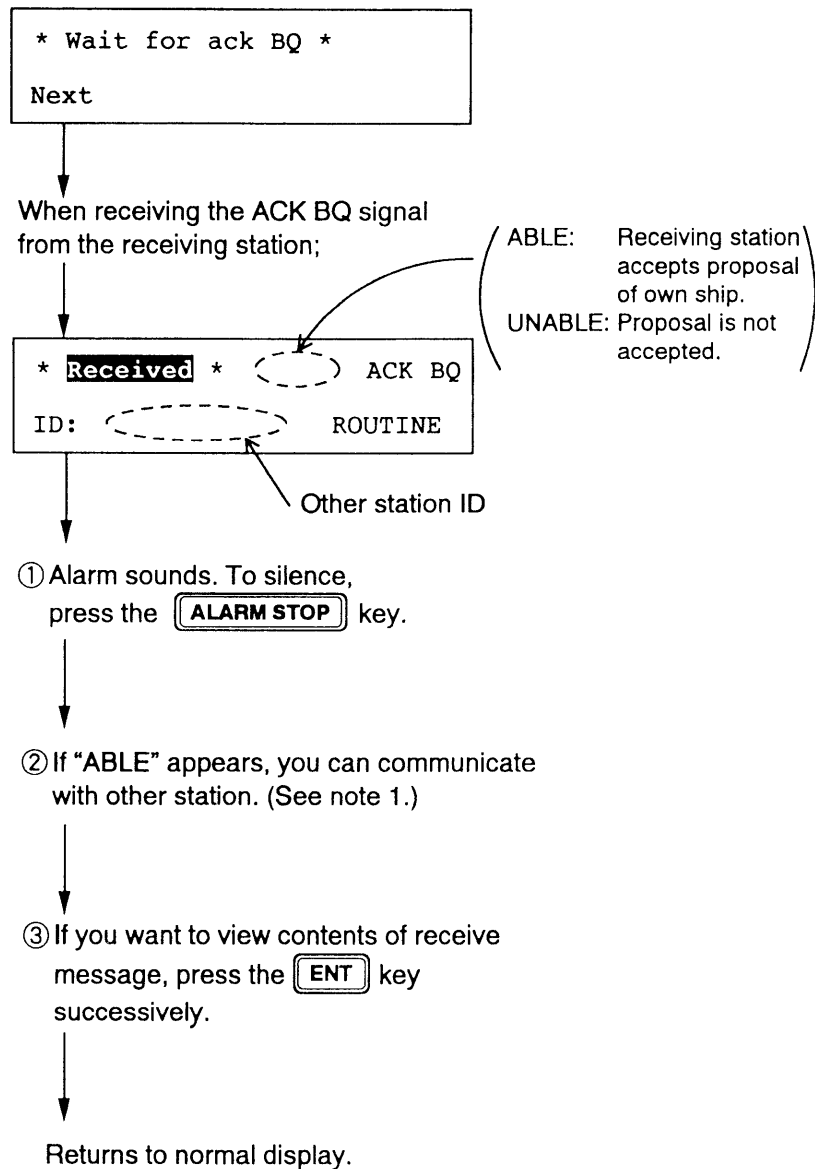

Note 1: If "UNABLE" appears, prepare a message with different proposal and transmit it by pressing the **CALL** key. Repeat until proposal is mutually accepted.

## 9.3 Receiving "Individual Call" (ACK RQ)

### General

When receiving an individual call, the operation of the DSC-6/6A depends on the setting of automatic acknowledge (AUTO ACK) function:

- **AUTO ACK: ON** ("auto" appears.)  
The DSC-6/6A transmits the acknowledge back (ACK BQ) signal automatically.
- **AUTO ACK: OFF** ("limit" or "manual" appears.)  
Verify contents of receive message by pressing the **ENT** key successively, then manually transmit the ACK BQ signal by pressing the **CALL** key.

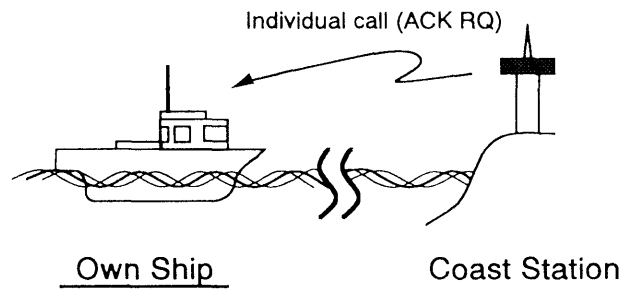

### Presetting of "ABLE" or "UNABLE"

When AUTO ACK function is ON, you can select either "able" or "unable" (to comply) for proposal from other station beforehand. See the next page.



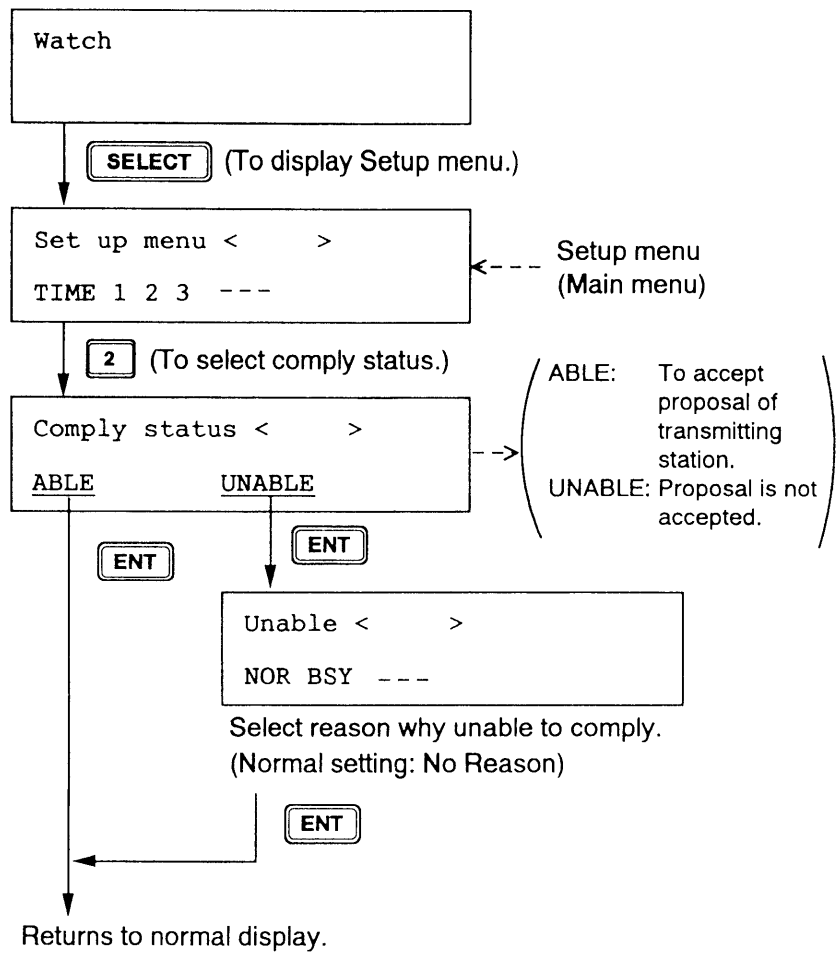

**Receiving a message (ACK RQ) with AUTO ACK On**

The DSC-6/6A sends the ACK BQ signal automatically.

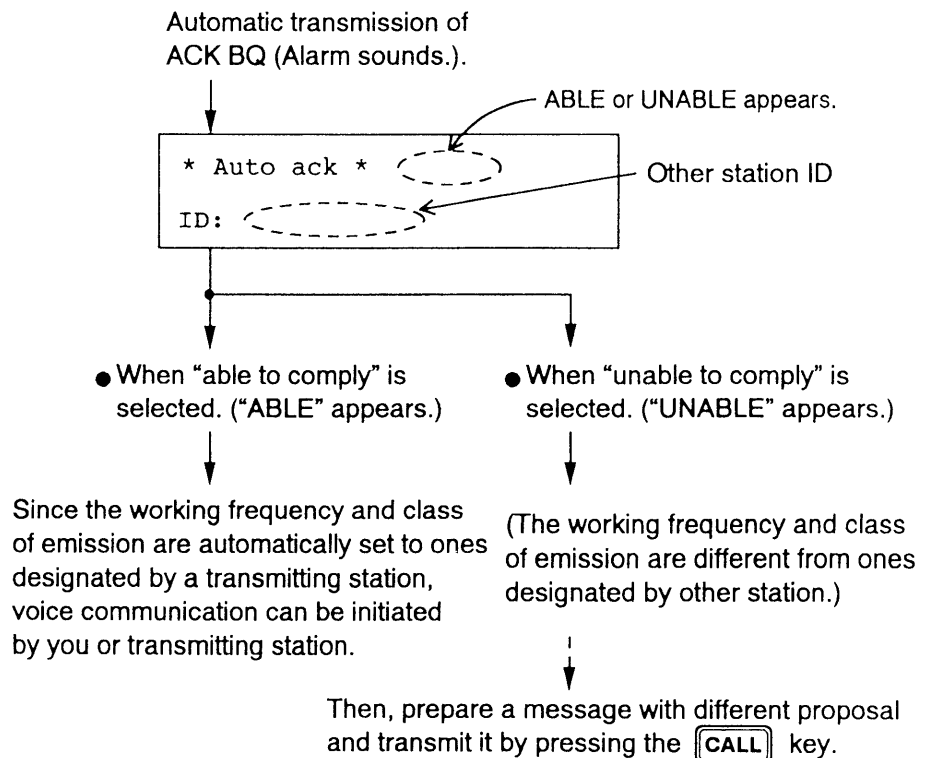

**Receiving  
ACK RQ with  
AUTO ACK Off**

After verifying contents of receive message, manually transmit the ACK BQ signal by pressing the **CALL** key within five minutes. If the signal is transmitted more than five minutes after reception of ACK RQ signal, it is treated as an ACK RQ signal rather than ACK BQ.

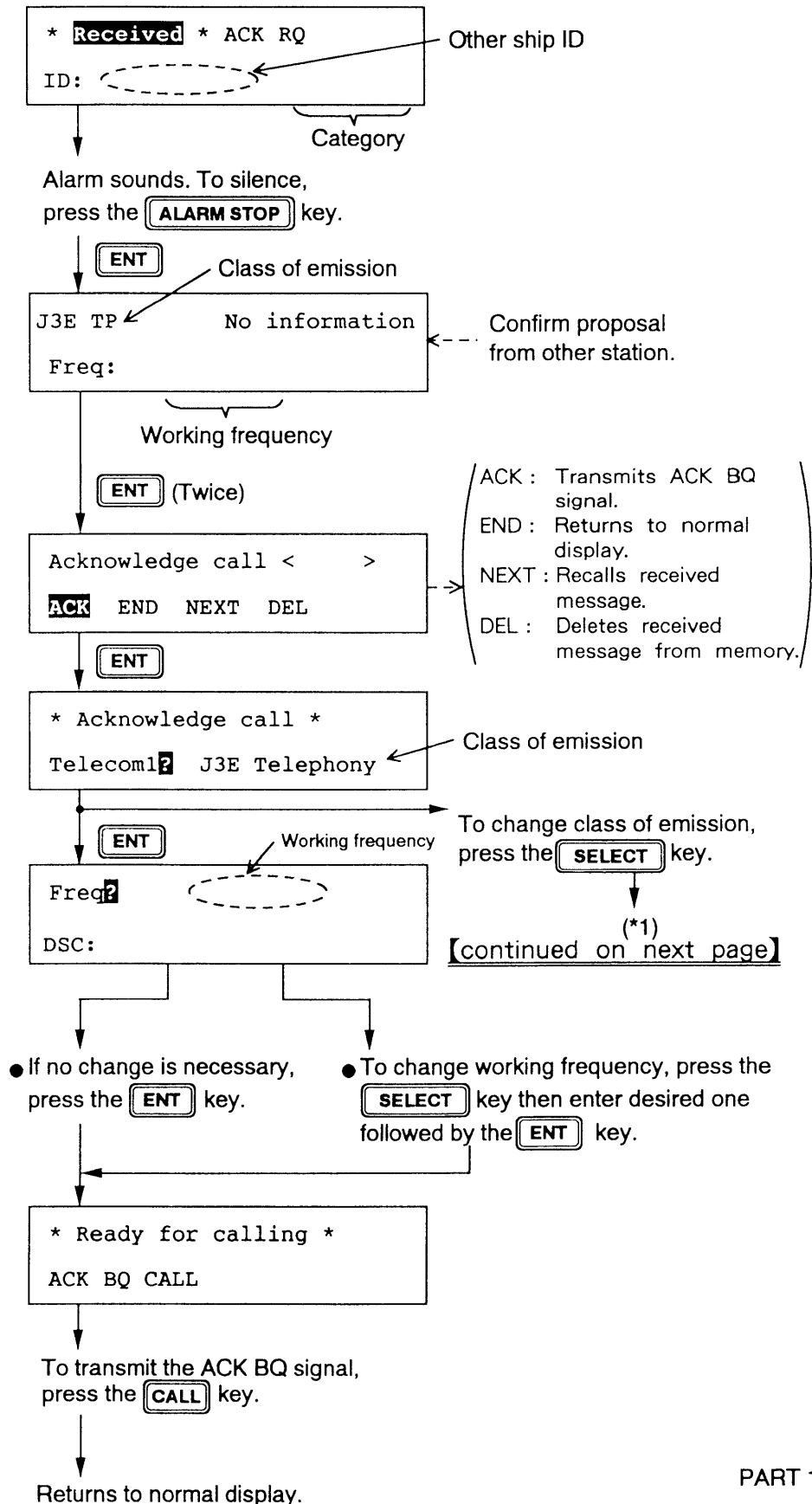

[from previous page]

(\*1) When changing class of emission.

```
Telecom1 < >
J3E H3E FEC --- UNA
```

Example when selecting "UNA" (Unable). (Proposal from transmitting station is not acceptable.)

ENT

```
Telecom unable comply?
No reason
```

SELECT (To select reason why unable to comply.)

```
Unable < >
NOR BSY ---
```

Select reason.

ENT

```
* Ready for calling *
ACK BQ CALL
```

CALL

```
Telecom1 < >
J3E H3E FEC ---
```

Example when selecting "H3E".

ENT

```
Freq?

```

SELECT (To change working frequency.)

```
NO FREQ CH POS
```

Enter working frequency.

ENT

If a different class of emission is selected as shown above, "ACK BQ" call is first transmitted and "ACK RQ" call automatically continues. This means the message proposed (prepared) here is transmitted as ACK RQ signal (not ACK BQ). Finally the "Wait for ACK BQ" screen appears.

# 10. Preparing and Saving Transmit Messages

## 10.1 Preparing and Saving Transmit Messages

### General

There are two ways to prepare and transmit a message:

1. Prepare a message for immediate transmission. (Refer to pages 8-1 and 9-1.)
2. Prepare a message and store it for later transmission.

You can save up to 99 transmit messages (excluding distress messages) to the memory. These are numbered 01 to 99.

### Procedure

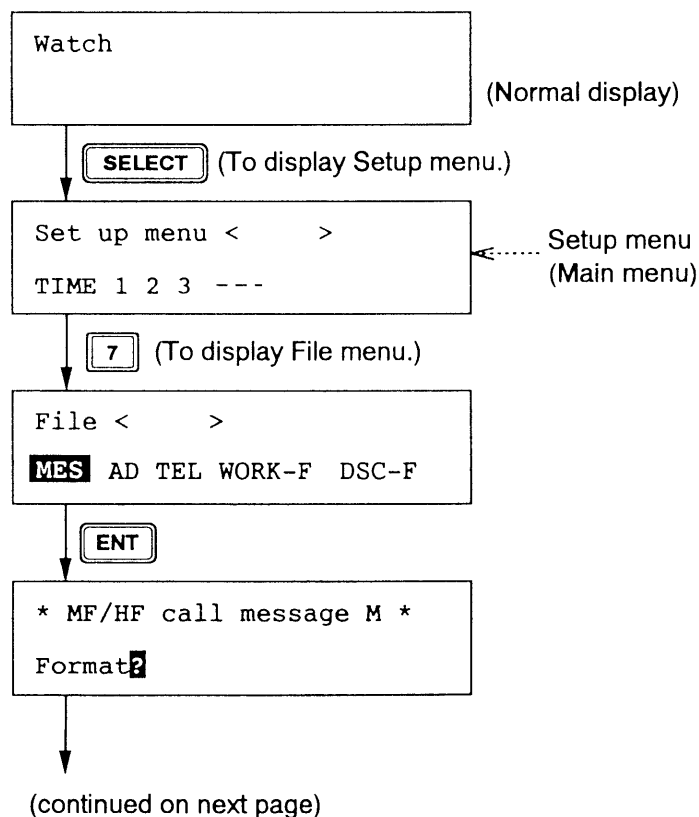

(from previous page)

Prepare a message by referring to page 8-1 (All Ships) and page 9-1 (Individual).

\* Ready for filing \*

**ENT** (To select file number under which to save message.)

Call message < >  
**01**/99:

To select a different file number, use the arrow keys.  
 (▶: Up, ◀: Down)

File No. (blinking)

**ENT** (To assign file name.)

Name < >  
**END** A B C D ----- R →

To scroll screen, press the ▶ key .

Assign a file name (max. 16 characters) by the arrow keys, **ENT** key and ten keys.

Example File Name: A1

1. Place the cursor on "A" with the arrow keys and press the **ENT** key.  
 (For alphabet always press **ENT** after selection.)
2. Press the **1** key.

To change specific character, move upper cursor first.

Press **SELECT** and ...

- ▶ : Moves upper cursor rightward every pressing.
- ◀ : Moves upper cursor leftward every pressing.

Name < A**1** >  
 END **A** B C D ---

To change entire name, press the **CANCEL** key.

Press ◀ to place the lower cursor on "END".

**ENT** →

Next file memory < >  
 END NEXT DELETE

Using the example above, the unit saves the transmit message to the memory (file no. 1) under the file name "A1".

**ENT**  
 Returns to normal display.

To prepare another message;  
**ENT**

\* MF/HF call message M \*  
 Format?

To delete file selected here.  
**ENT**

## 10.2 Retrieving and Transmitting a File

### Retrieving a file

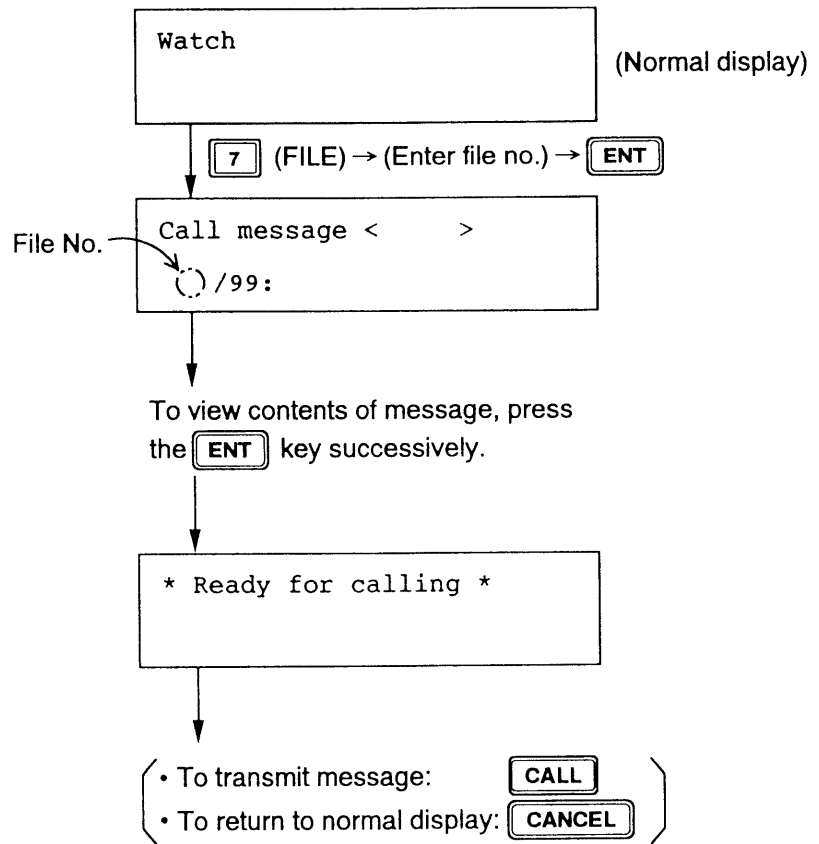

### Transmitting a file

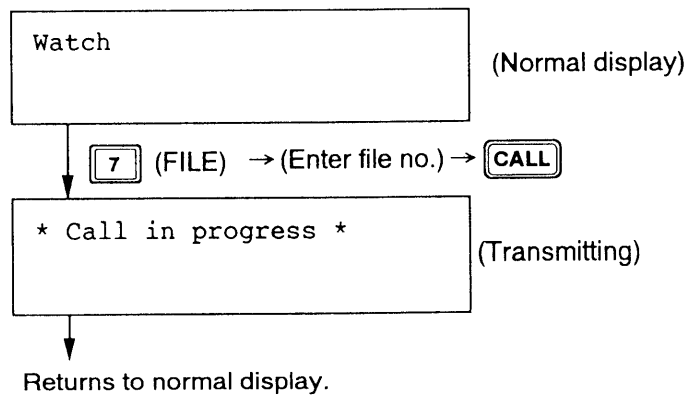

# 11. Transmit/Receive Message Memory

## 11.1 Transmit Message Memory

### General

The transmit message memory stores **up to 50 transmitted messages** (numbered 1 to 50) on a first-in, first-out basis. This means each time you save a transmitted message it is filed as log no. 1 and the log no. of all previously stored transmit messages changes by one. When the memory is full the oldest file is deleted.

### Retrieving a transmit message

Press the **[9]** (XMTD) key at the normal display.

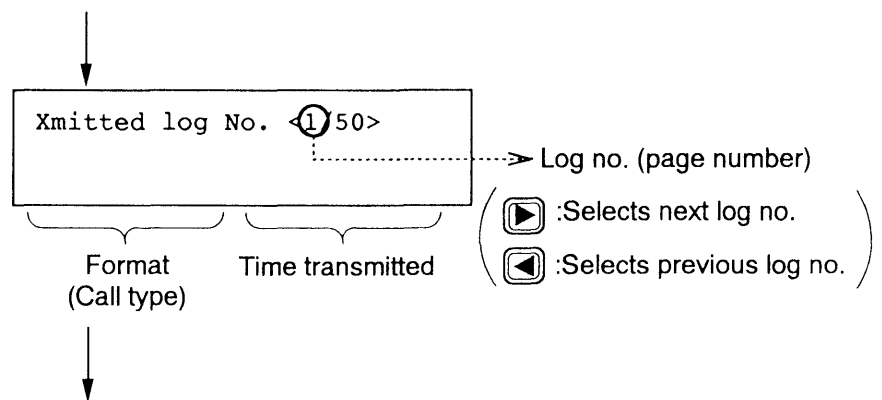

To view contents of message, press the **[ENT]** key successively.

### Transmitting retrieved message

You can transmit a retrieved message as follows.

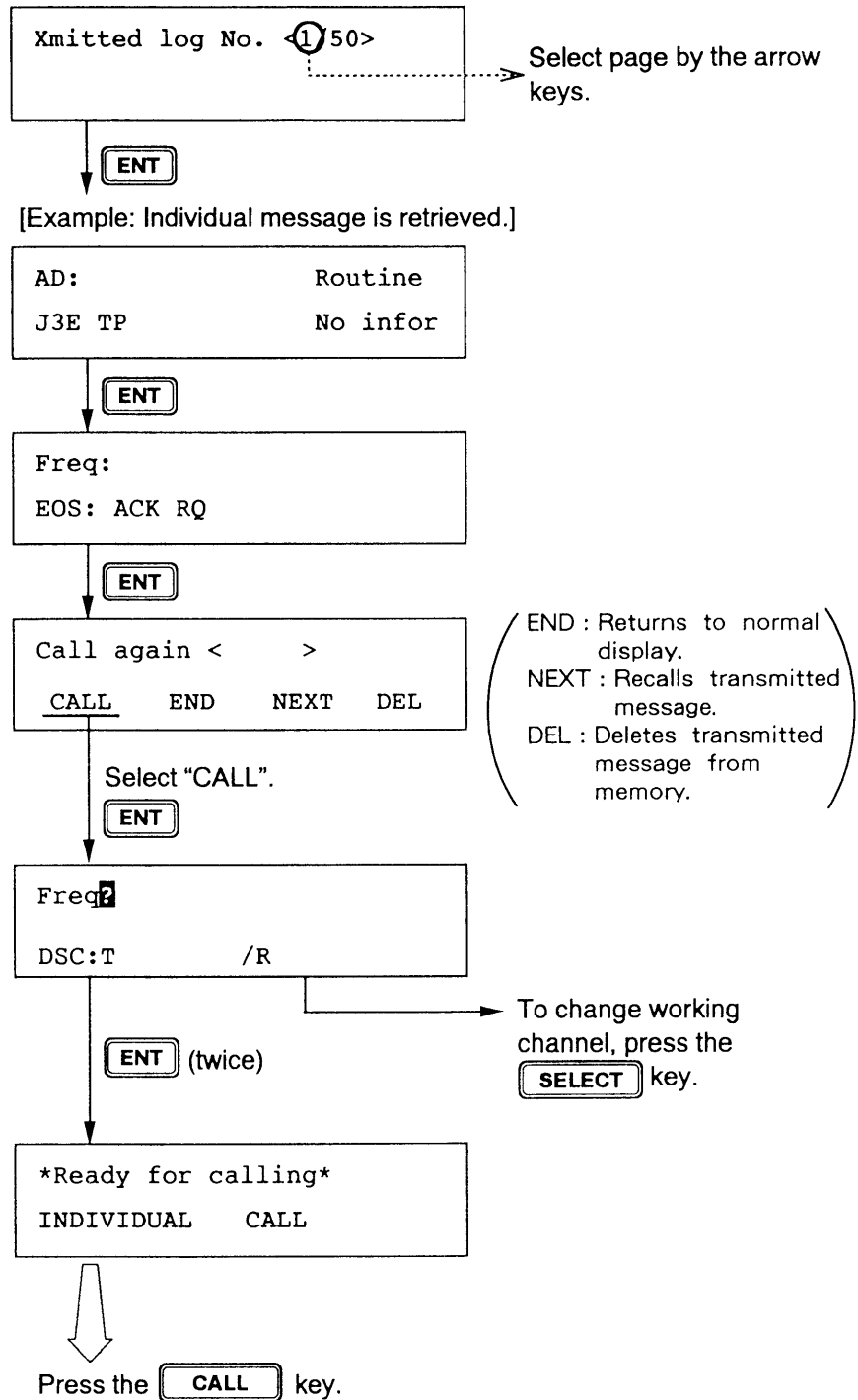



# 11.2 Receive Message Memory

## General

All received messages are automatically saved to the memory and filed according to category, DISTRESS or ORDINARY. The receive message memory can store **up to 50 messages** (numbered 1 to 50) of each category on a first-in, first-out basis. This means each time the unit receives a message it saves it as log no. 1 and changes the log no. of all previously received messages by one. When the memory is full the oldest file is deleted.

## Retrieving a receive message

Press the **[8]** (RCVD) key at normal display.

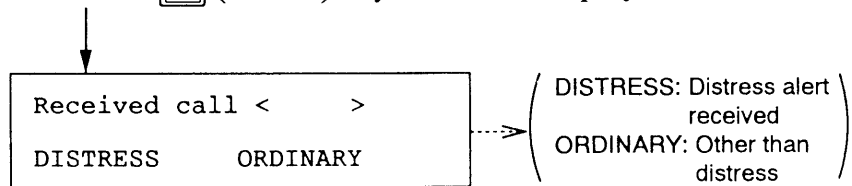

For example, "ORDINARY" log;

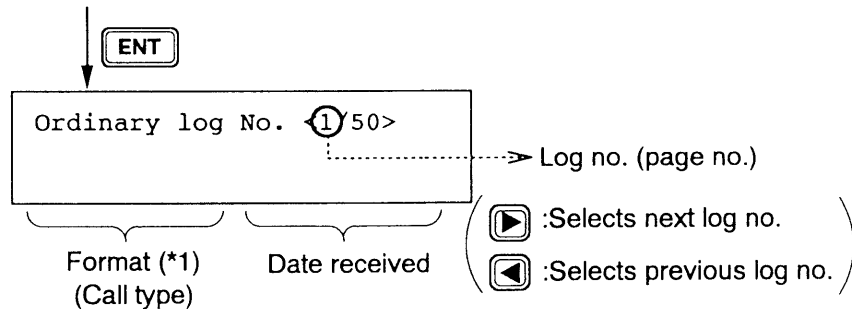

To view contents of message, press the **[ENT]** key successively.

(\*1) : If own ship did not transmit "ACK BQ" (acknowledge back) signal a blinking sharp symbol (#) appears at head of Format.

**Transmitting retrieved message**

You can send the acknowledged call (DIST ACK or ACK BQ) under certain conditions after retrieving a received message. Refer to page 5-1 for transmitting the DIST ACK signal.

Example: Transmit acknowledge back (ACK BQ) signal in response to an individual call (Refer to page 9-7.)

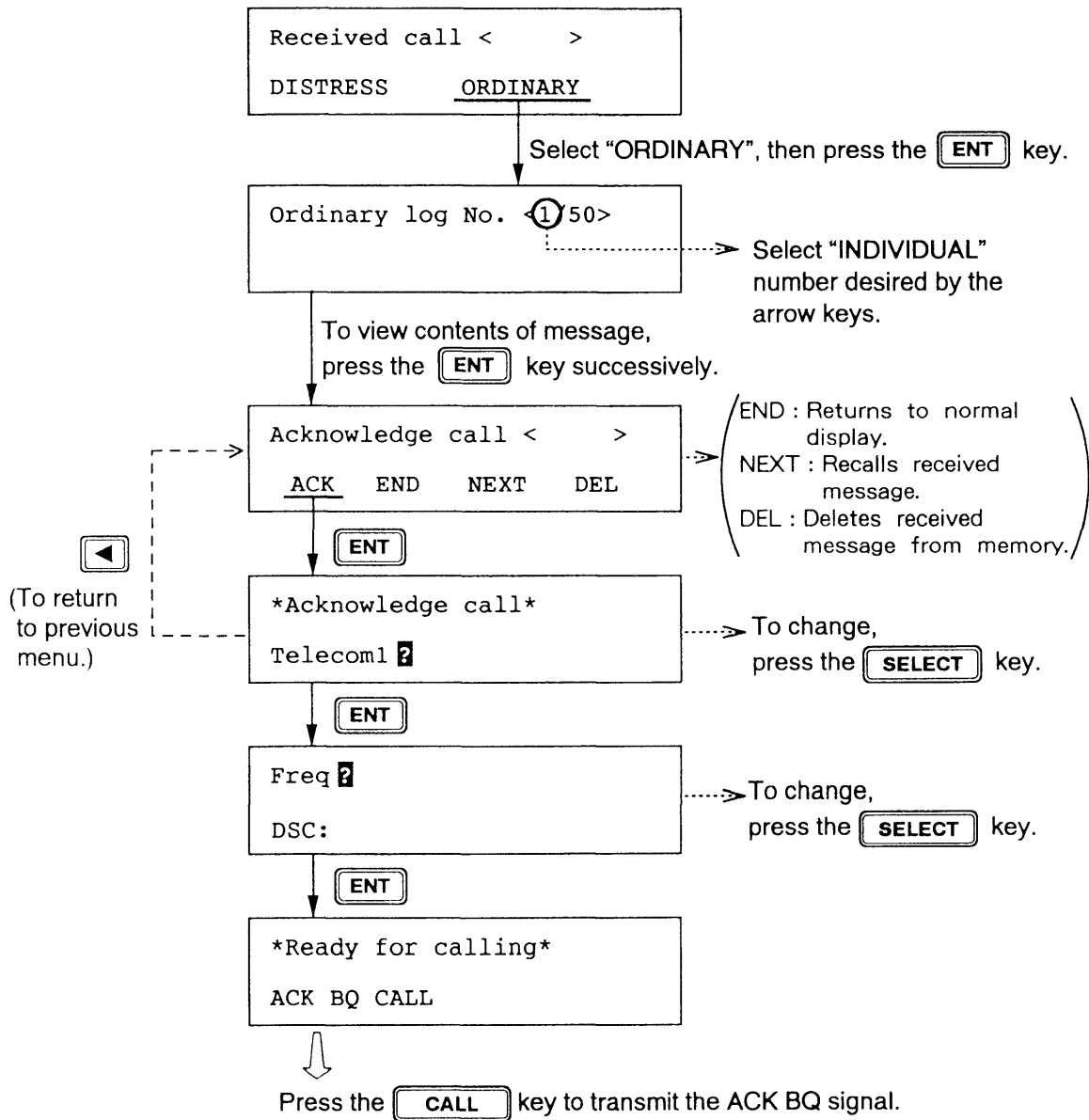

**NOTE:** If the signal is transmitted more than five minutes after reception of ACK RQ signal, it is treated as an ACK RQ signal rather than ACK BQ. Finally the "Wait for ACK BQ" screen appears.

# 12. Other Calling Types and Other Functions

## 12.1 Other Calling Types

### General

The DSC-6/6A provides 13 calling types. Of these, individual, all ships and distress were discussed in previous chapters. This section describes the other types of calls available. The procedure for preparing and transmitting other calls is the same as that for individual and all ships calls: Select type of call, prepare message and transmit it by pressing the **CALL** key.

### Selection of calling type

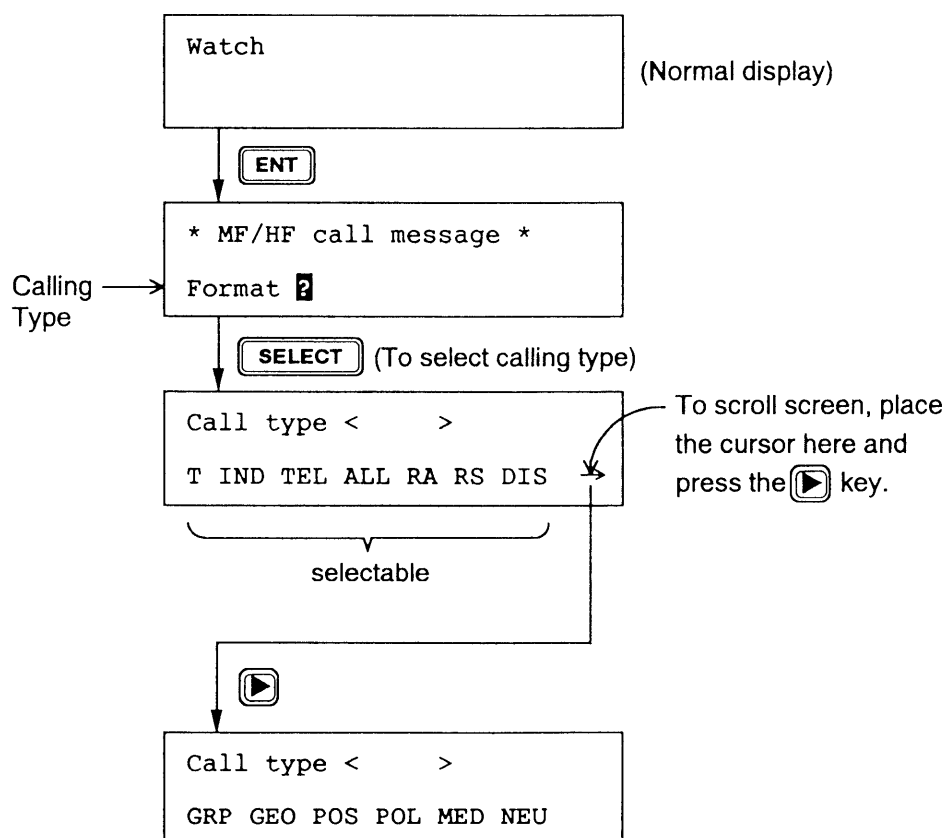

Description of all 13 calling types appears on the next few pages.

- **T** : **Test call (Refer to page AP2-5)**  
Test transmission on Distress/Safty frequency.
- **IND** : **Individual call (Refer to page 9-1.)**
- **TEL** : **PSTN call (semi-auto/auto call)**  
Call a terrestrial network, for example, your office through a coast station.
- **ALL** : **All ships call (Refer to page 8-1.)**
- **RA and RS** : **Distress relay for All ships and for Selective (Individual) calls (Refer to page 4-3.)**
- **DIS** : **Distress call (Refer to page 3-1)**
- **GRP** : **Group call**  
Call a specific group by entering group ID number.
- **GEO** : **Geographic area call**  
Call for ships within a range set by you in the transmit message (menu). To designate the range, enter reference point and width (range) data of both longitude and latitude.

Example: Ocean AD · · 34N 135E da10 do5

Range data

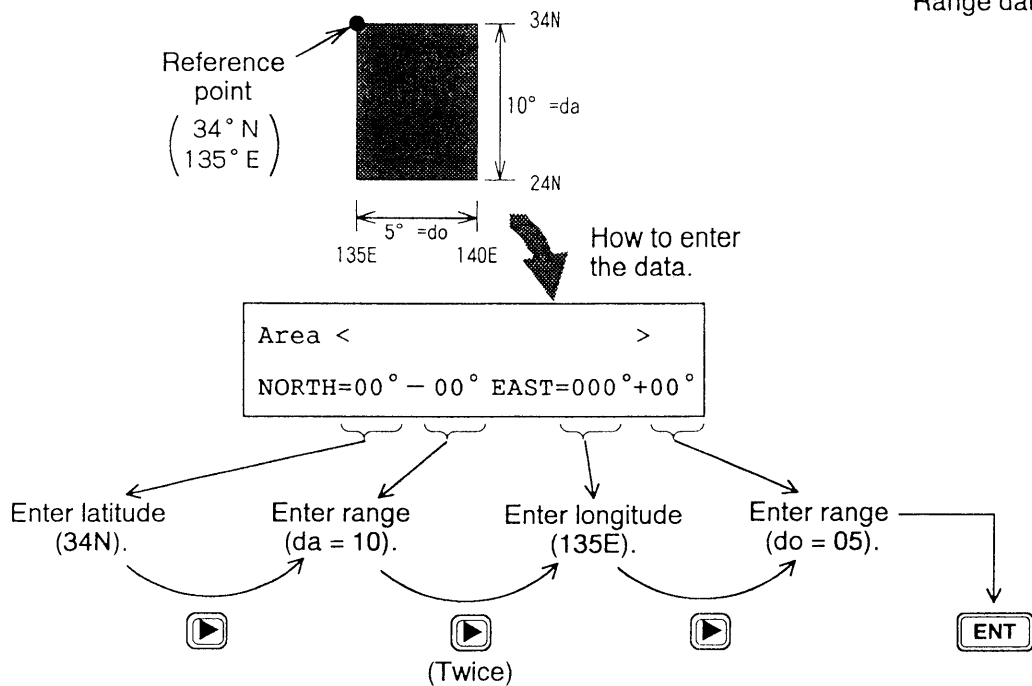

- **POS** : **Position request (Individual call  
Refer to page AP2-1.)**

Find position of other ship by entering its ID number.
- **POL** : **Polling call (Individual call  
Refer to page AP2-3.)**

Confirm that own ship is within communication range with other ship. This provides only negative response; it does not provide position information.
- **MED** : **Medical transport (All ships call)**

Inform all ships, by using “urgent” category, that own ship carries medical goods.
- **NEU** : **Neutral craft (All ships call)**

Inform all ships that own ship is not a participant in an armed conflict.

# 12.2 File Menu

## Registering

You can program often-used station IDs, telephone numbers and so on under a file name.

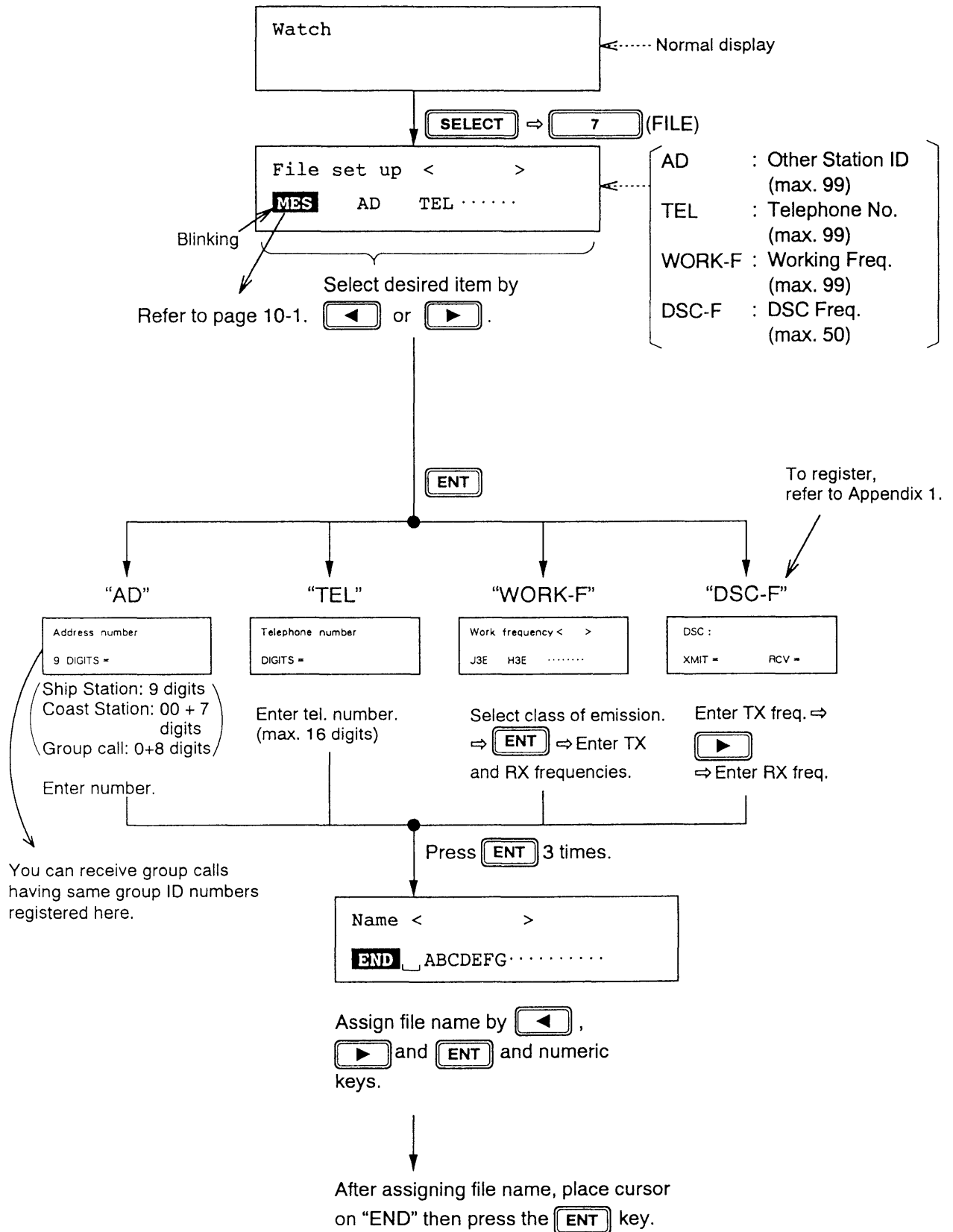

## Retrieving

You can retrieve a file registered on previous page, and use it with message which you are currently preparing.

To retrieve a file, **press the 7 (FILE) key on a display where the blinking question mark appears.**

[Example]

### 1. Retrieving Other Station ID

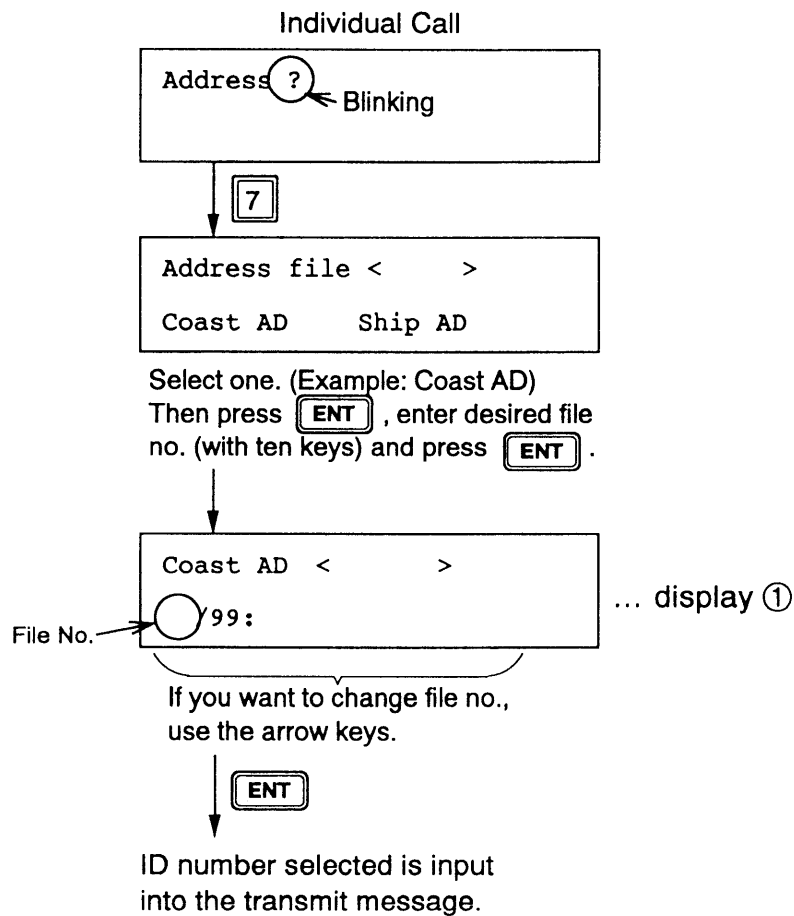

NOTE: Each press of the SELECT key at display ① alternates file number and alphabet prefixed file name.

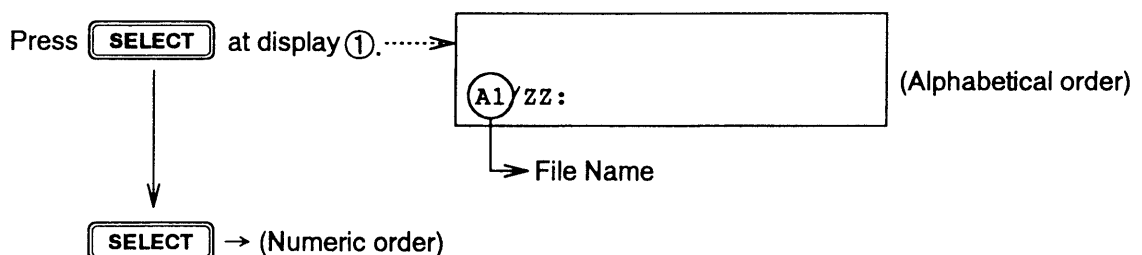

# 13. Printer Setup (Auto/Manual)

## General

You can select either automatic or manual printing by following the procedure shown below. (Factory setting: Auto)

## Procedure

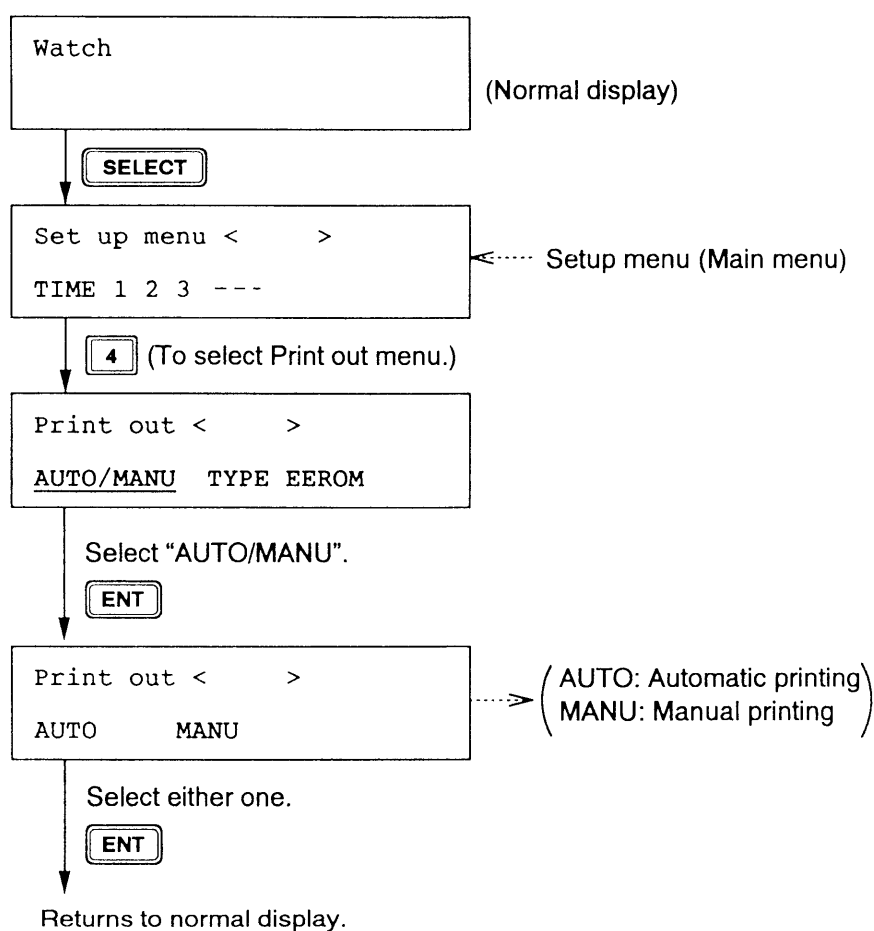

## Automatic printing

When "AUTO" is selected, all transmitted and received messages will be automatically printed out when transmitted and received.

## Manual printing

When "Manual" is selected, press the **4** (PRINT) key to print out message desired. Note that manual printing is available even when "AUTO" is selected.

The contents to be printed depend on when the **4** key is pressed, as shown in the table below.



No.	Printing	Timing of <b>4</b> key pressing	Example Printout
1	Contents of {MF/HF call message}	During "MF/HF call message" display to "Ready for calling" display.	(a)
2	Contents of all transmitted logs {Xmitted log No. < >}	Displayed [Xmitted log No. < >] (To stop printing, press <b>CANCEL</b> .)	(b)
3	Contents of specific log no. (for example, log no. 1) {Xmitted log No. <1/50>} <b>ENT</b>	During "[Xmitted...]" ⇒ <b>ENT</b> display to "EOS" display.	(c)
4	Call message (again) Call again CALL END_ <b>ENT</b>	<div style="border: 1px solid black; padding: 5px; display: inline-block;">           Freq? DSC: to Ready for calling         </div> While these displays appear.	(a)
5	Contents of all received logs {Ordinary log No. < > (Distress)}	Displayed [Ordinary log No. < > (Distress)] (To stop printing, press <b>CANCEL</b> key.)	(d)
6	Contents of specific log no. (for example, log no. 1) {Ordinary log No. <1/50> (Distress)}	[Ordinary ...] display ⇒ <b>ENT</b> *Received* to ECC: OK	(e)
7	① Currently received message *Received* <b>ENT</b> ② Acknowledge message Acknowledge call < >	"Ready for calling" is displayed.	(f)
8	Contents of currently prepared {MF/HF call message M}	During "MF/HF call message M" display to "Ready for filing" display.	(g)
9	All lists of {saved messages} or contents of all {Address , Tel No., work freq. or DSC freq.} files. • <b>SELECT</b> ⇒ <b>7</b> File < > <b>MES</b> AD ..... Press <b>4</b> to print out all list of saved messages.	• For example, to print out all coast addresses in the memory, press <b>4</b> at display ① on page 12-5.	(h)

## Example printouts

(a) Format : INDIVIDUAL  
Address : 000000000  
Category: Routine  
Telecom1: J3E TP  
Telecom2: RES No.18  
Freq : T12230.0/R13077.0  
EOS : ACK RQ  
ECC : ....  
  
DSC freq: T12578.5/R12658.0

(c) Xmt message JAN01 00:09  
Format : INDIVIDUAL  
Address : 004310000  
Category: Routine  
Telecom1: J3E TP  
Telecom2: RES No.18  
Freq : T12230.0/R13077.0  
EOS : ACK BQ  
  
DSC freq: T12578.5/R12658.0

(e) Rcv message JAN01 00:07  
Format : INDIVIDUAL  
Address : 431000001  
Category: Routine  
Telecom1: J3E TP  
Telecom2: RES No.18  
Freq : T12230.0/R13077.0  
EOS : ACK RQ  
ECC : OK  
  
DSC freq: T12578.5/R12658.0

(f) Format : INDIVIDUAL  
Address : 431000001  
Category: Routine  
Telecom1: J3E TP  
Telecom2: RES No.18  
Freq : T12230.0/R13077.0  
EOS : ACK BQ  
ECC : ....  
  
DSC freq: T12578.5/R12658.0

(h) \*\*\*\* Call message file \*\*\*\*  
01: FURUNO Individual  
02: CAPTAIN All ships

(b) \*\*\*\*\*Xmitted log\*\*\*\*\*  
Xmt message JAN01 12:34  
Format : INDIVIDUAL  
Address : 004310000  
Category: Routine  
Telecom1: J3E TP  
Telecom2: RES No.18  
Freq : T12230.0/R13077.0  
EOS : ACK BQ  
  
DSC freq: T12578.5/R12658.0

(d) \*\*\*\*\*Ordinary log\*\*\*\*\*  
Rcv message JAN01 02:04  
Format : ALL SHIPS  
Category: Safety  
Telecom1: J3E TP  
Telecom2: RES No.18  
Freq : T02182.0/R02182.0  
EOS : EOS  
ECC : OK  
  
DSC freq: T02187.5/R02187.5

Rcv message JAN01 02:03  
Format : INDIVIDUAL  
Address : 004310001  
Category: Safety  
Telecom1: J3E TP  
Telecom2: RES No.18  
Freq : No information  
EOS : ACK RQ  
ECC : OK  
  
DSC freq: T02187.5/R02187.5

(g) Format : INDIVIDUAL  
Address : 000000000  
Category: Routine  
Telecom1: J3E TP  
Telecom2: RES No.18  
Freq : T12230.0/R13077.0  
EOS : ACK RQ  
ECC : OK  
  
DSC freq: T12578.5/R12658.0

# 14. Menu List

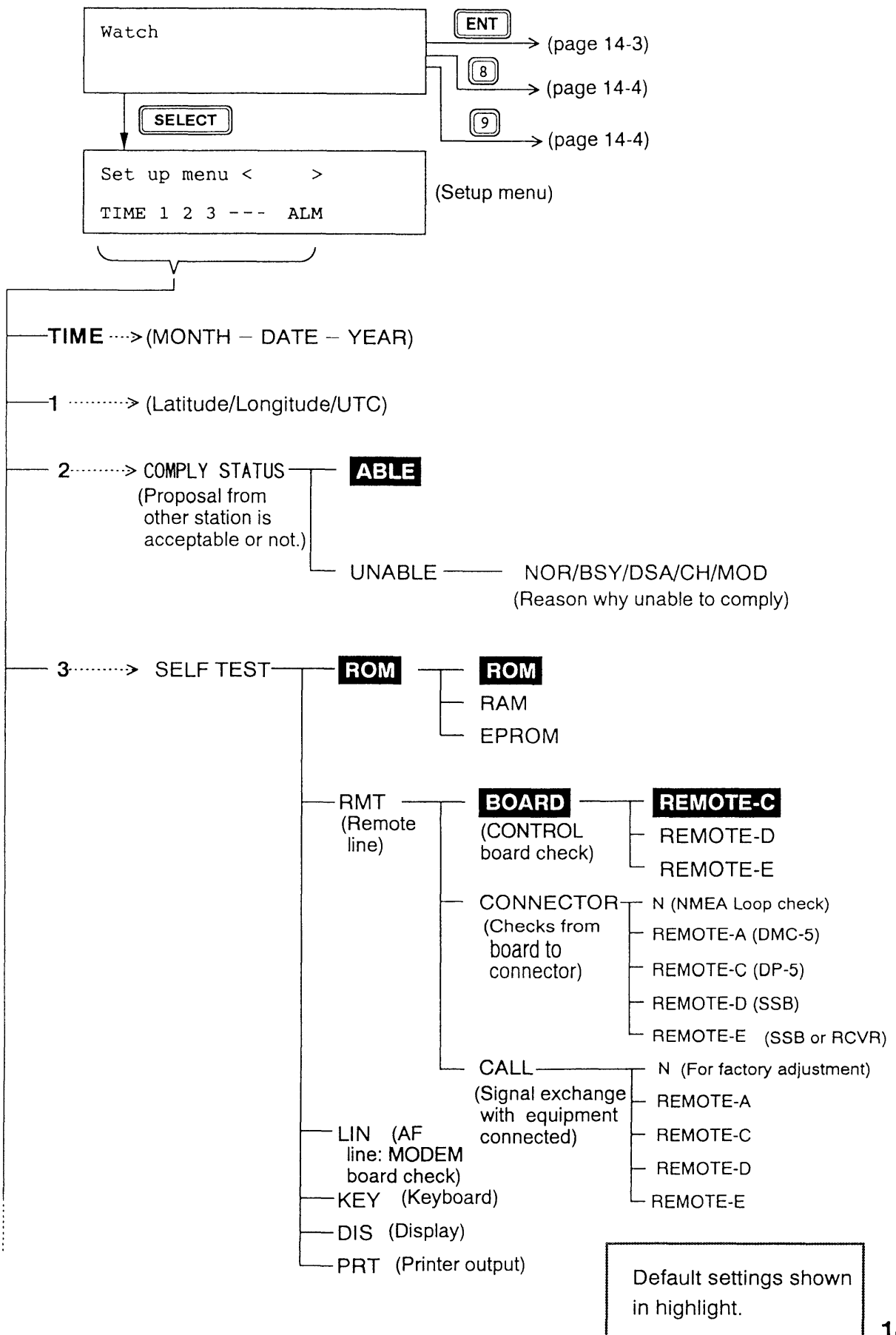

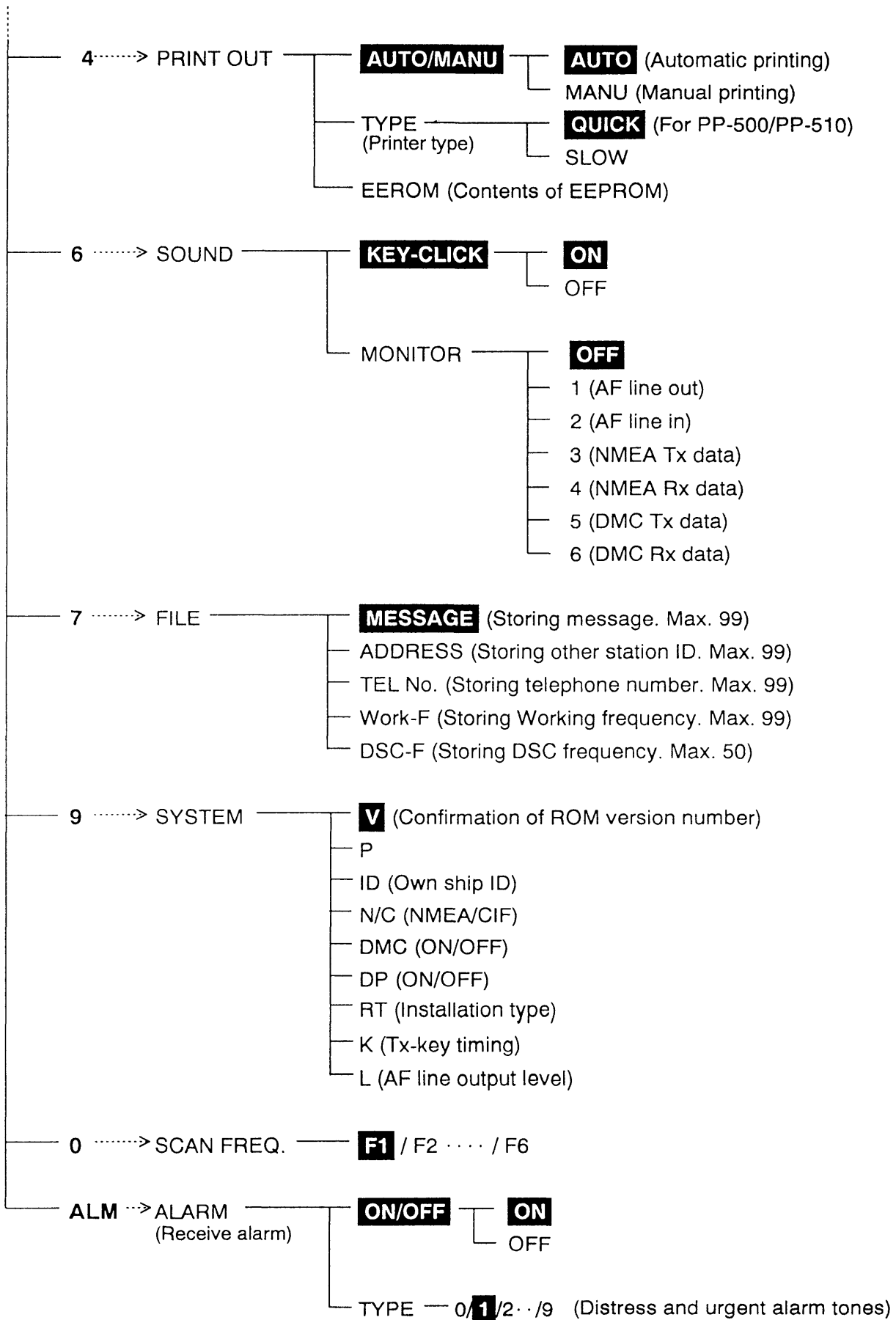

Default settings shown in highlight.

Normal display

ENT

\* MF/HF call message \*  
Format ?

(Preparing transmit message)

FORMAT (CALL TYPE)

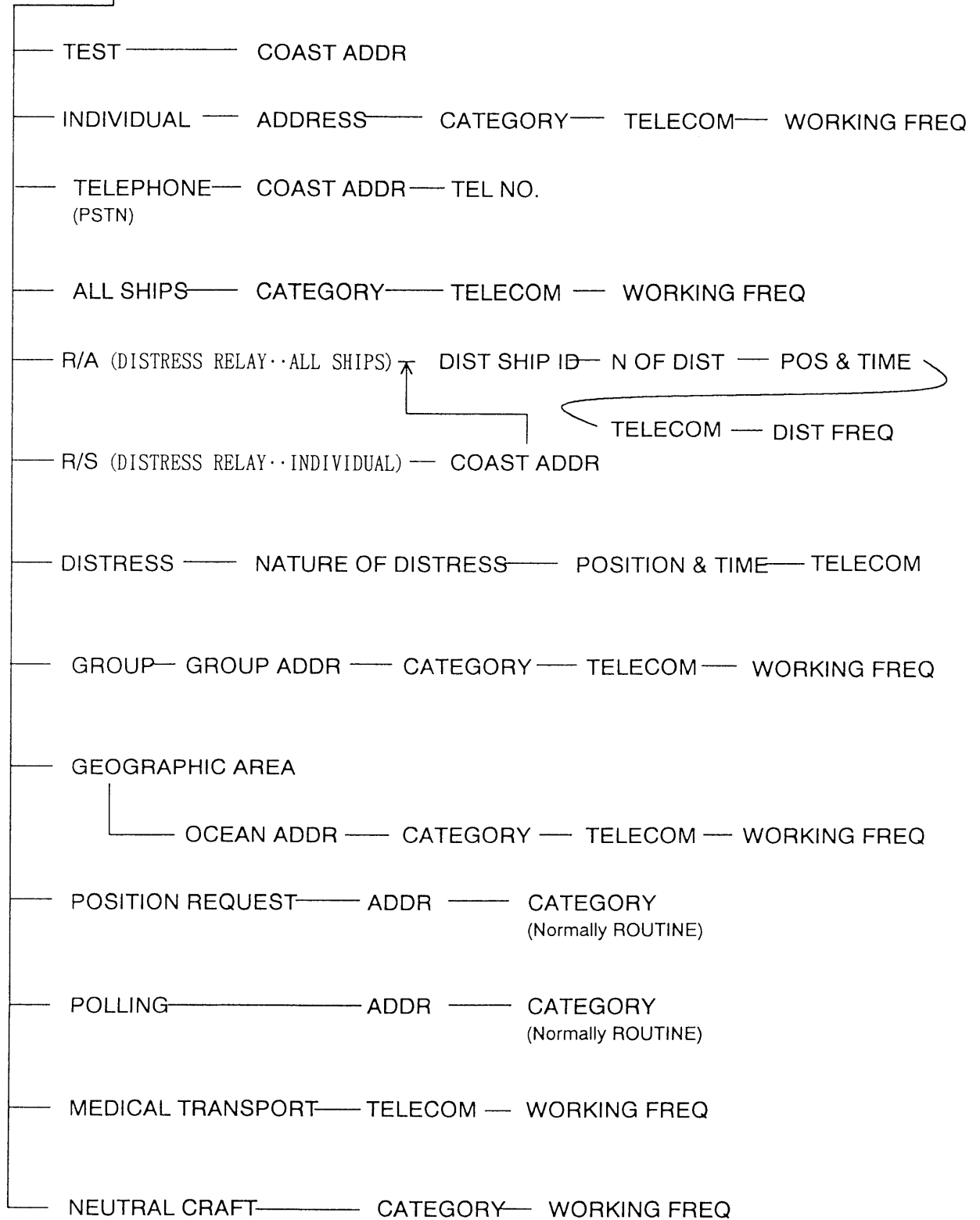

Normal display

8

Received call < >  
DISTRESS    ORDINARY

(Viewing contents of receive message)

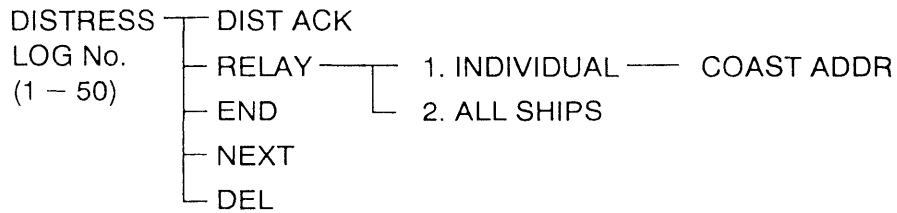
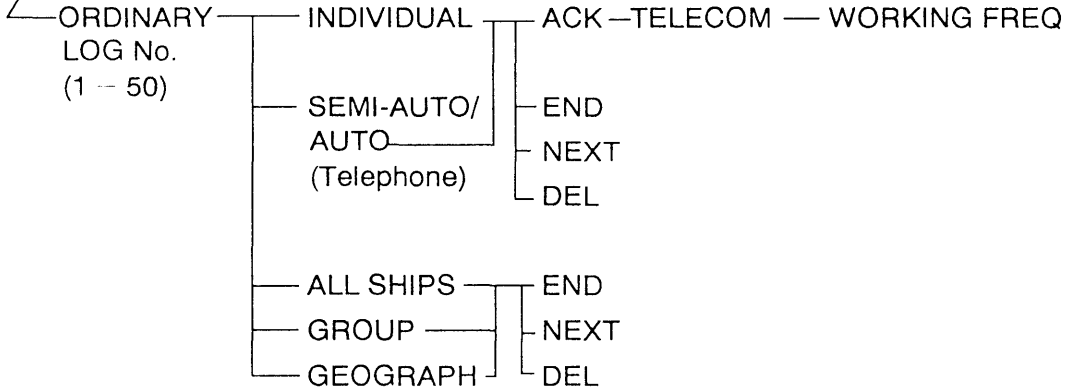

Normal display

9

Xmitted log No. < >

(Viewing contents of transmit message)

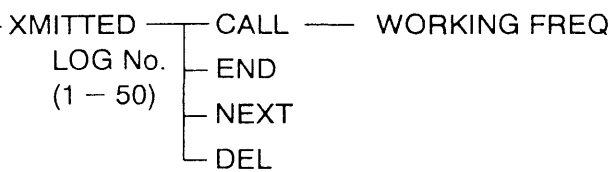

# Appendix 1

## DSC Frequency Table

File No.	TX (kHz)	RX (kHz)	REMARKS	File name
	2187.5	2187.5	DISTERSS/SAFTY FREQUENCIES	
	4207.5	4207.5		
	6312.0	6312.0		
	8414.5	8414.5		
	12577.0	12577.0		
	16804.5	16804.5		
10	458.5	455.5	INTERNATIONAL FREQUENCIES	INTL-0.4M
11	2189.5	2177.0		INTL-2M
12	4208.0	4219.5		INTL-4M
13	6312.5	6331.0		INTL-6M
14	8415.0	8436.5		INTL-8M
15	12577.5	12657.0		INTL-12M
16	16805.0	16903.0		INTL-16M
17	18898.5	19703.5		INTL-18M
18	22374.5	22444.0		INTL-22M
19	25208.5	26121.0		INTL-25M
22	4208.5	4220.0	LOCAL FREQUENCIES (DEPENDING ON COUNTRY)	LOCAL1-4M
23	6313.0	6331.5		LOCAL1-6M
24	8415.5	8437.0		LOCAL1-8M
25	12578.0	12657.5		LOCAL1-12M
26	16805.5	16903.5		LOCAL1-16M
27	18899.0	19704.0		LOCAL1-18M
28	22375.0	22444.5		LOCAL1-22M
29	25209.0	26121.5		LOCAL1-26M
32	4209.0	4220.5		LOCAL2-4M
33	6313.5	6332.0		LOCAL2-6M
34	8416.0	8437.5		LOCAL2-8M
35	12578.5	12658.0		LOCAL2-12M
36	16806.0	16904.0		LOCAL2-16M
37	18899.5	19704.5		LOCAL2-18M
38	22375.5	22445.0		LOCAL2-22M
39	25209.5	26122.0		LOCAL2-25M

Note 1: TX: 2177.0 kHz, RX: 2177.0 kHz ···· For intership calling

# Appendix 2 Application

Beside its primary function of providing distress and general calling, the DSC-6/6A can also perform several other useful functions.

## 1. Finding Position of Other Station

To find the position (incl. time data) of other station; for example, your scout boat, do the following:

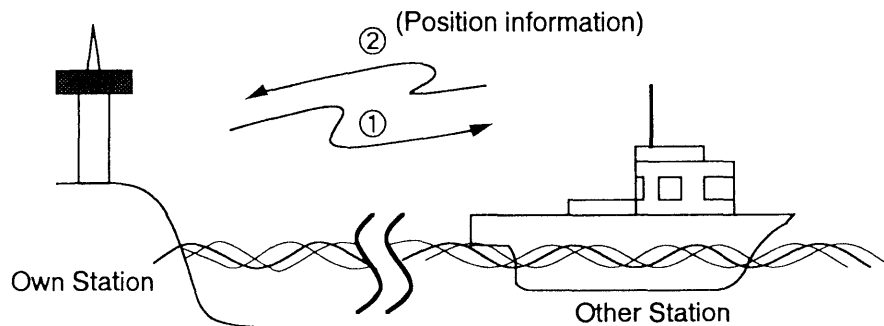

### Settings

Format: POSITION REQUEST  
Address: Other Station ID (9 digits)  
Category: ROUTINE

### Procedure

1. Set up the unit as prescribed above then press the **CALL** key. The "Wait for ack BQ" screen appears.
2. Receive acknowledge back signal from other station.

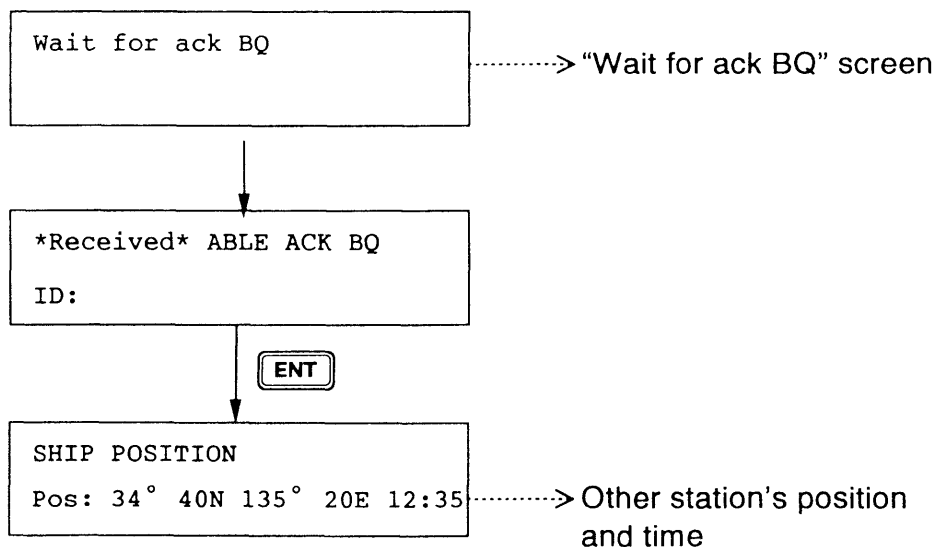



## 2. Transmitting Own Ship's Position to Other Stations

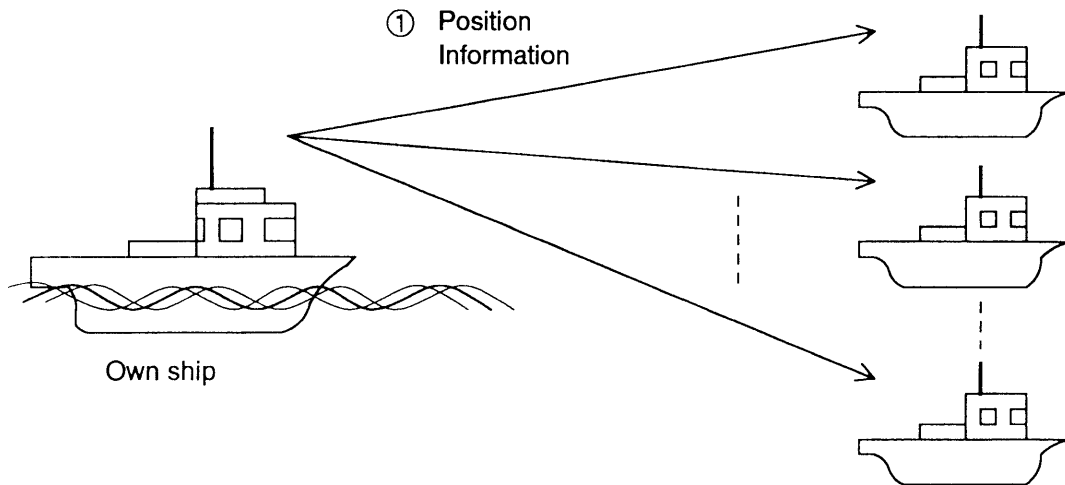

### Settings

Format: GROUP or GEOGRAPH  
 Address: GROUP ID Number (0 + 8 digits) or Input of geographic area  
 Category: ROUTINE  
 Working frequency: POS

### Procedure

1. Set up the unit as prescribed above. Key in own ship's position (if necessary) then press the **CALL** key.

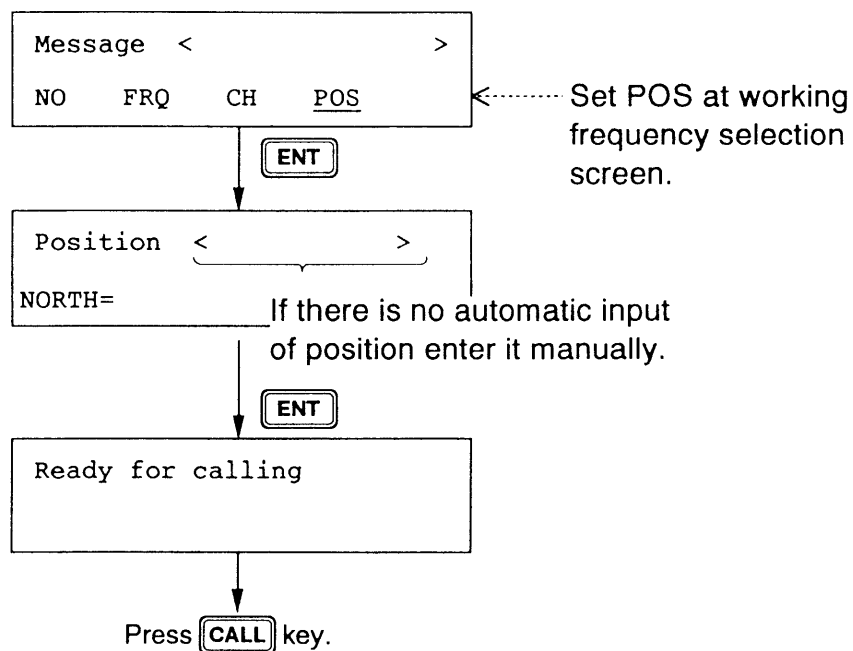

### 3. Polling

Polling means confirming if own station is within communicating range with other station. This function provides only affirmative or negative response; it does not provide position information. Note also that simultaneous polling to more than one station is not possible.

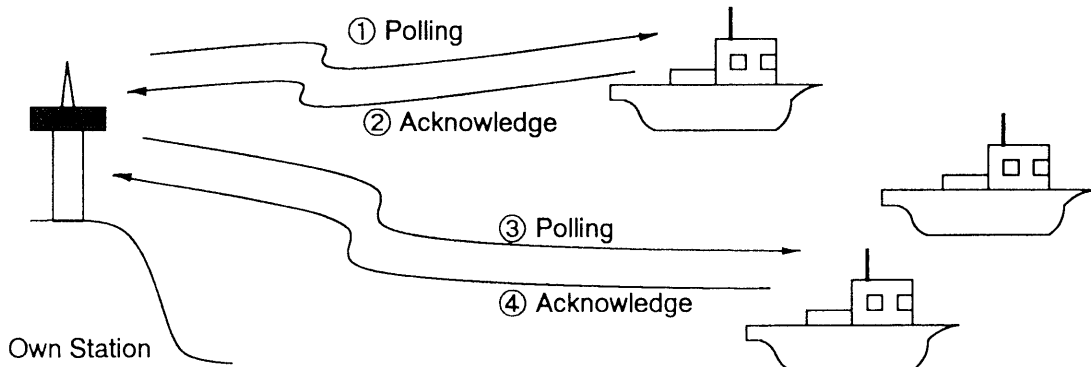

#### Settings

Format: POLLING  
 Address: Other Station ID (9 digits)  
 Category: ROUTINE

#### Procedure

1. Set up the unit as prescribed above then press the **CALL** key. The “Wait for ack BQ” screen appears.

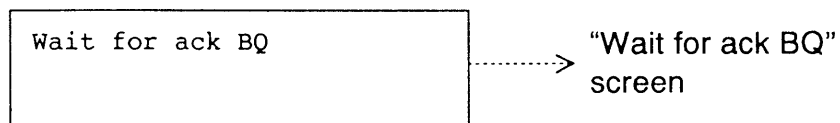

2. Receive the acknowledge back signal from the other station. If the following screen appears **your station is within communicating range** with the other station.

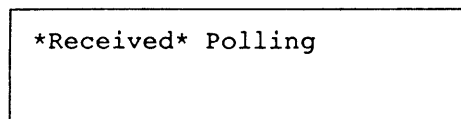

## 4. Telex Operation with the DP-5

The figure below shows how to connect the DP-5 to the DSC-6/6A and SSB radiotelephone for telex communication.

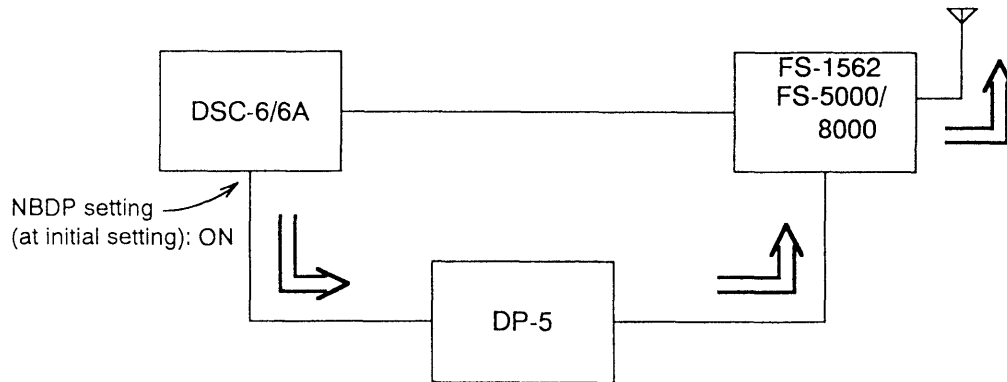

When the DSC-6/6A transmits individual call message with a TELEX telecommand and receives ACK BQ signal, it automatically relays (transfers) **other station ID**, **class of emission (FEC, ARQ, TTY)** and **Working frequency** to the DP-5. (The 9 digit-select ID code of the DP-5 should be entered. Otherwise, they are not transferred.) Then to begin TELEX communication by the DP-5, simply select that station name on the station list menu. That station which is denoted by “DSC plus data/time the message was received,” should be at the top of the list.

For all ships, group and geographic area calls, after the DSC-6/6A transmits a message with a TELEX command, the same data as shown above are automatically transferred from the DSC-6/6A to the DP-5.

## 5. Test call

Since one of six distress and safety frequencies is used for test call, do not use this function unnecessarily.

### Procedure

1. Press the **ENT** key at the normal display.

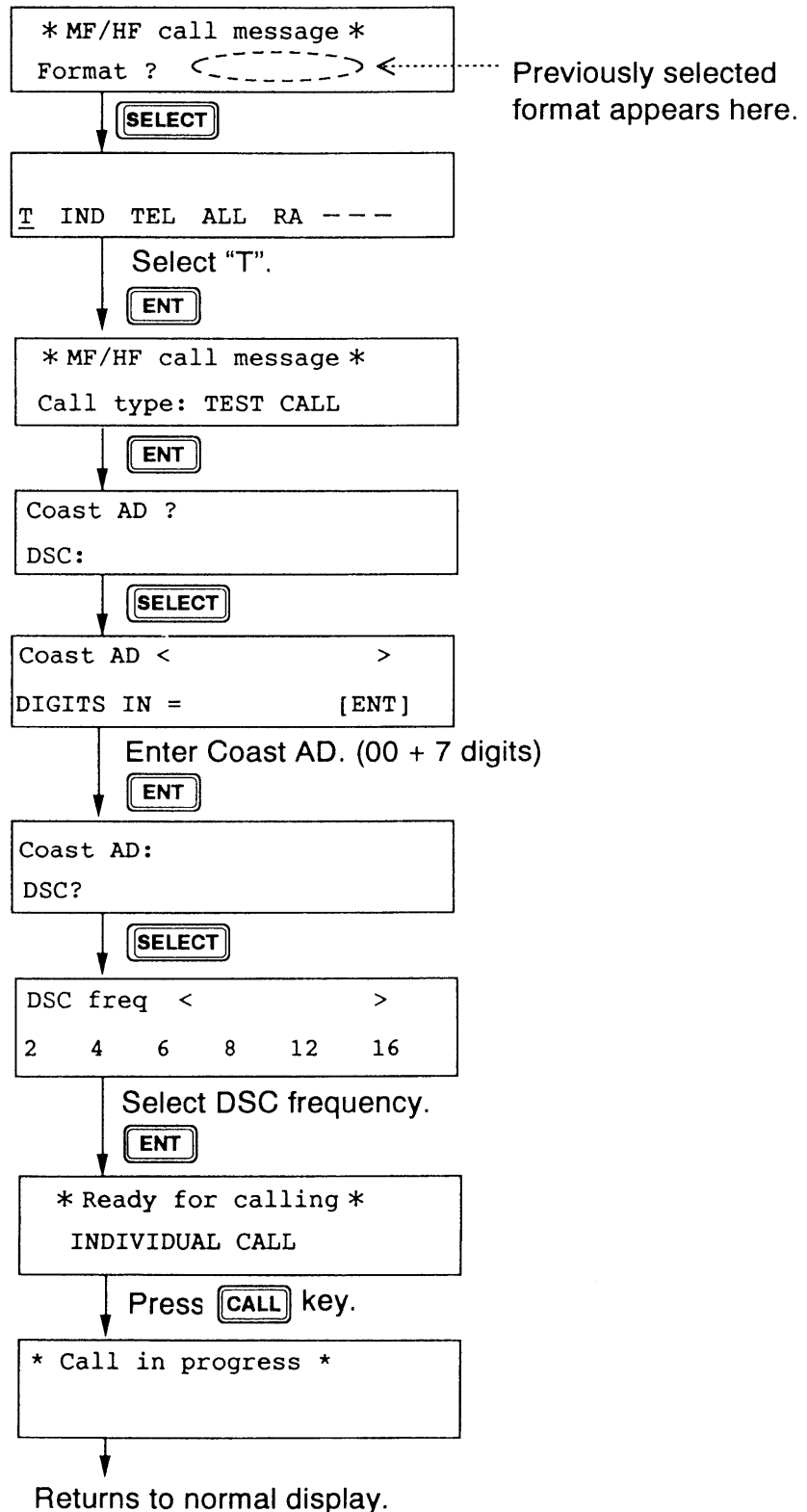

# PART 2

---

# Maintenance

# **PART 2 Table of Contents**

(Maintenance)

	<u>Page</u>
<b>1. Daily Operating Test</b> .....	<b>1-1</b>
<b>2. Visual Check</b> .....	<b>2-1</b>
<b>3. Self-test for Technician</b> .....	<b>3-1</b>
<b>4. Error Messages</b> .....	<b>4-1</b>
4.1 Distress Calling .....	4-1
4.2 General Calling .....	4-1
<b>5. About Internal Battery</b> .....	<b>5-1</b>

# 1. Daily Operating Test

## General

This unit is equipped with a self diagnosis test which checks for proper operation. We recommend daily execution of the test to ensure proper transmission in case of distress. (Set the frequency of radiotelephone other than 2182 kHz.)

## Procedure

Press the **3** key at the normal display.

## Contents of Test

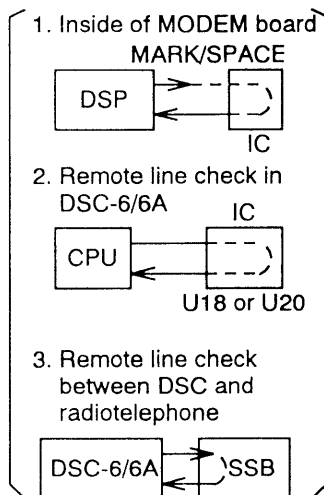

Communication check between CONTROL & MODEM boards.

Checking inside of MODEM board.

### Causes of NG

1. Power of DMC-5 is off.
2. System setting of DMC-5 is off.
3. Faulty remote line.

Checking inside of CONTROL board.

### Causes of NG

1. Power of FS-5000 is off.
2. Faulty remote line.

DSC-6A only  
(2187.5kHz RECEIVER board check)

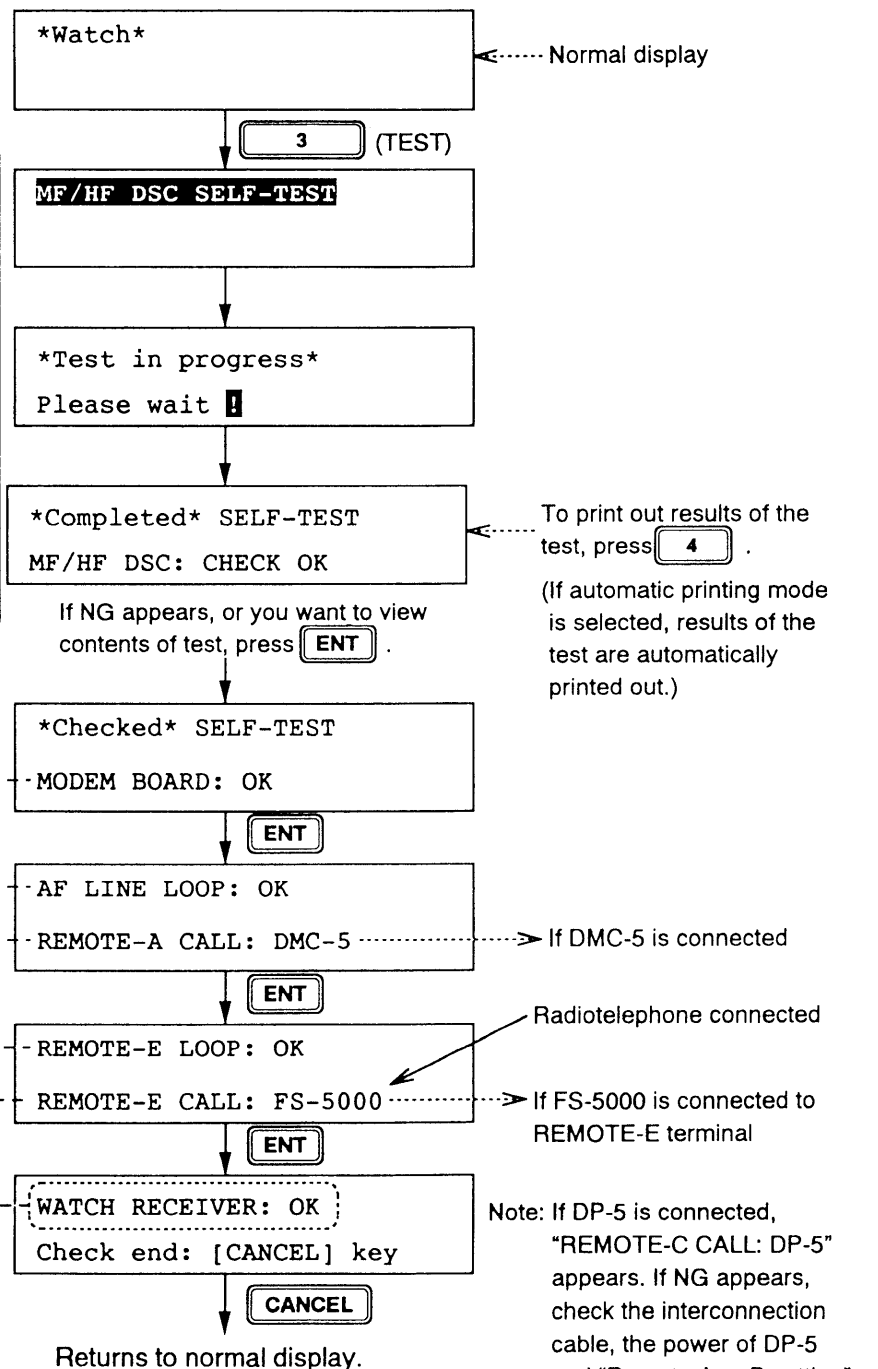

## 2. Visual Check

---

### **General**

This unit can perform its intended functions only when properly maintained. Following the procedures shown below will help keep it in top operating condition. **Be sure to turn off the power before performing any maintenance procedures** (except cleaning the display unit).

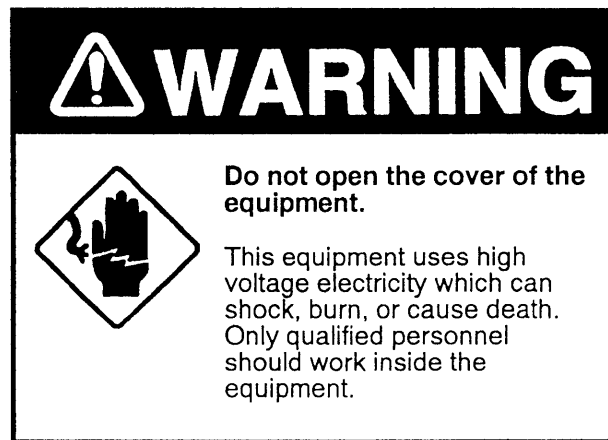

### **Cleaning display unit**

Accumulated dust can be removed with a soft, dry cloth. Do not use gasoline, thinner, benzine or other solvents to clean the display unit. These may remove paint and markings.

### **Inspecting connectors and earth terminal**

Periodically inspect the connectors and earth terminal on the rear of the unit for tightness.



# 3. Self-test for Technician

## General

This self-test is mainly intended for use by the service technician to identify the cause of operating problems.

## Procedure

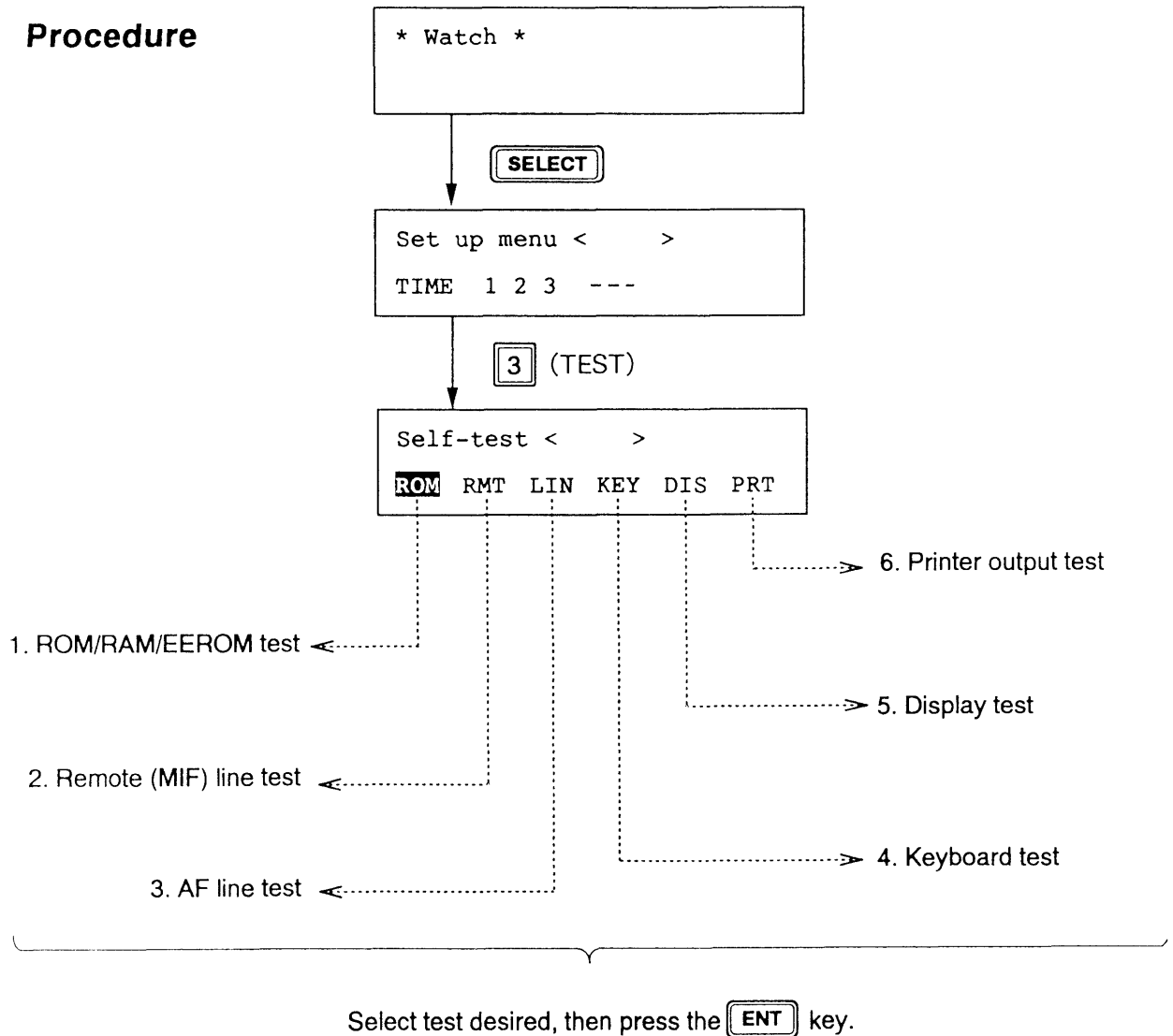

## ROM/RAM test

This test checks the ROM (U8), RAM (U9 and U10) and EEPROM (U11) on the CONTROL board for proper operation.

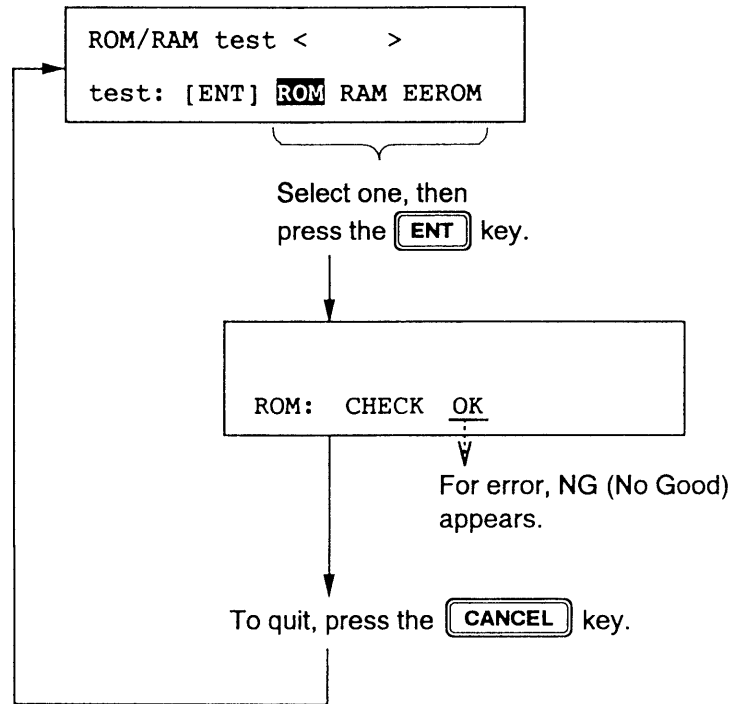

## AF line test

This test checks the DSP (U1) and A/D D/A Converter (U15) on the MODEM board for proper operation.

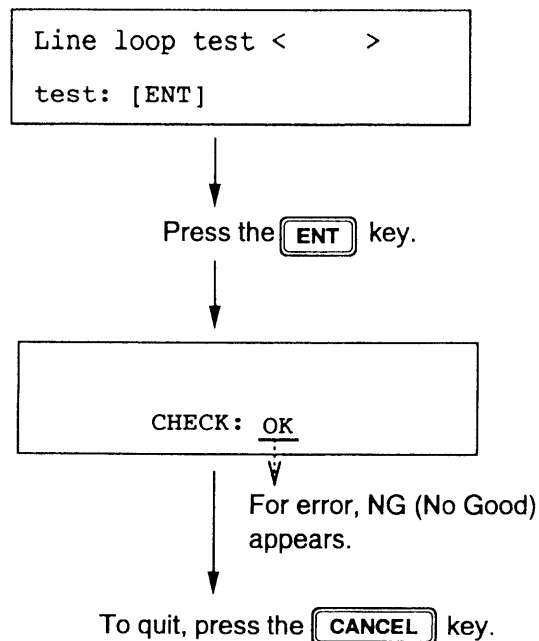

## Remote line test

This test checks the remote signal line (MIF data line) for proper operation.

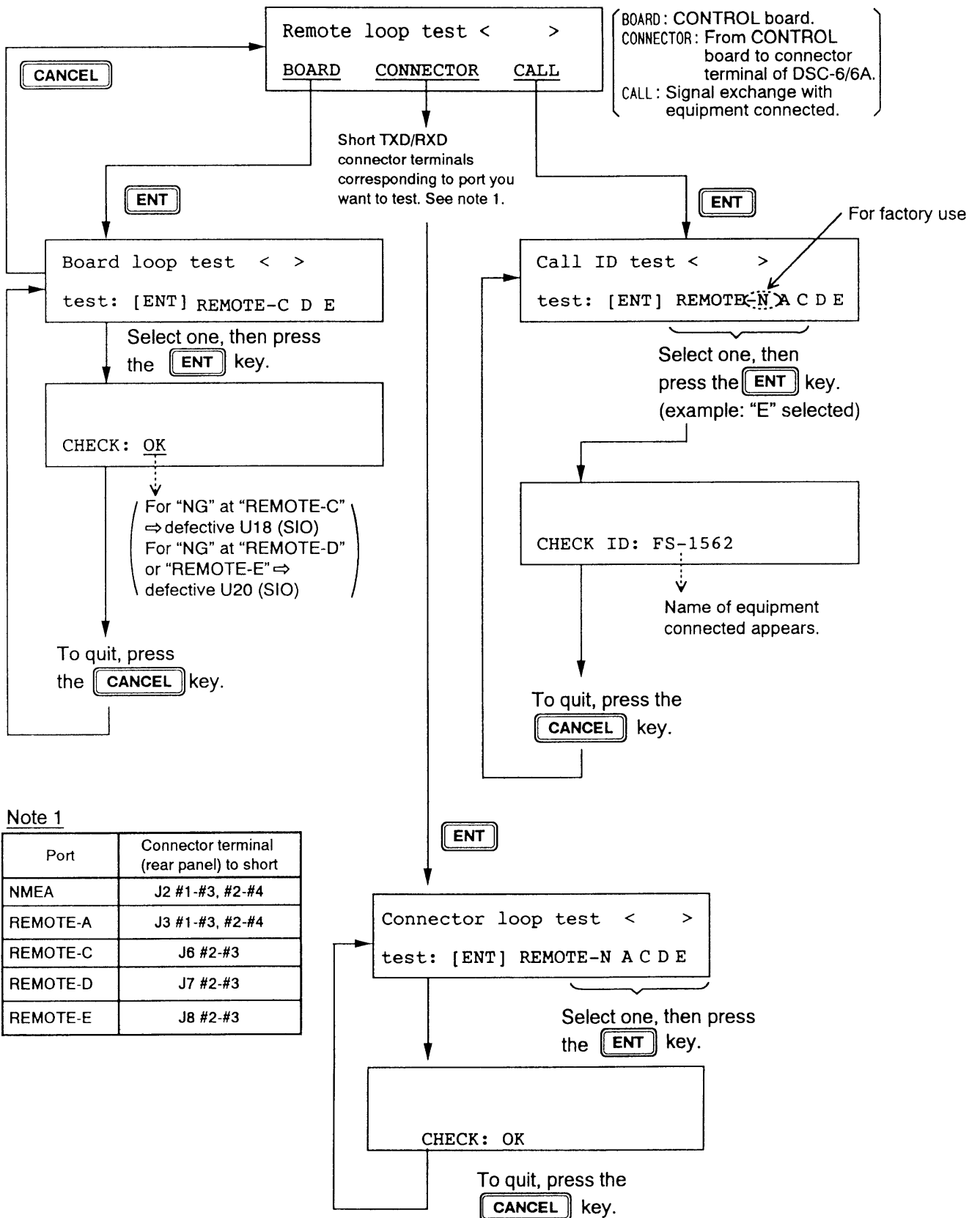

### Note 1

Port	Connector terminal (rear panel) to short
NMEA	J2 #1-#3, #2-#4
REMOTE-A	J3 #1-#3, #2-#4
REMOTE-C	J6 #2-#3
REMOTE-D	J7 #2-#3
REMOTE-E	J8 #2-#3

## Keyboard test

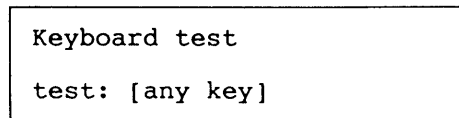

Press keys one by one.  
The number (or character) corresponding to the key pressed appears if the key is functioning properly.

## Display test

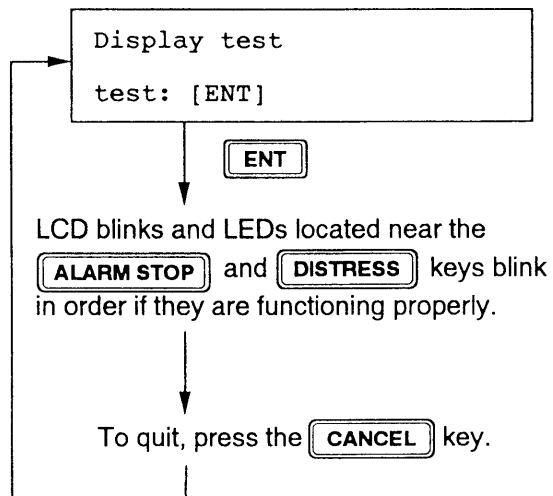

## Printer output test

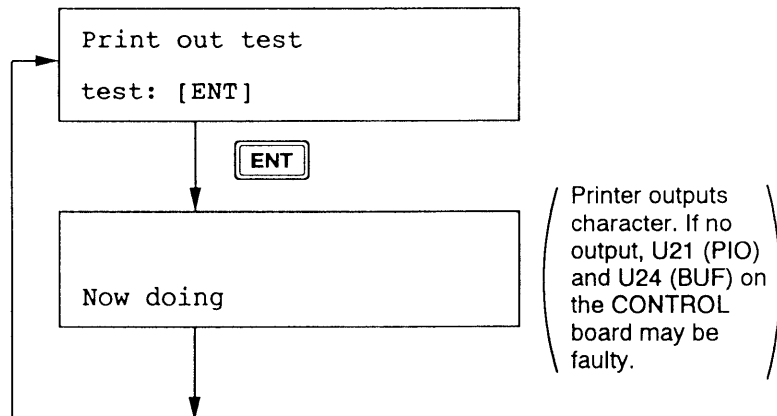

# 4. Error Messages

## 4.1 Distress Calling

If the error message shown below appears when pressing the **DISTRESS** key, check whether the radiotelephone is turned on or off. If off, turn it on and press the **CANCEL** key then press the **DISTRESS** key again to transmit alert. If on, set the DSC frequencies at the radiotelephone side manually and press the **DISTRESS** key to transmit alert.

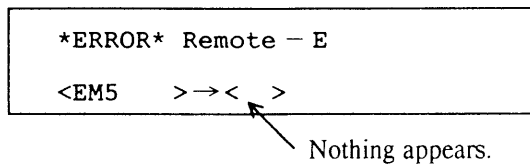

Note that the second press of the **DISTRESS** key turns the remote function off.

## 4.2 General Calling

If the error message shown in Fig. 1 or Fig. 2 appears when trying to transmit a DSC message by pressing the **CALL** key, do the following. (Message is not transmitted.)

### • Error Message ①

### Operation

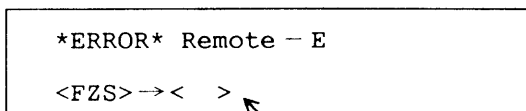

Fig. 1

See note 1 on next page.

Check whether the radiotelephone is turned on and connection cables between it and DSC terminal are secure. If not turned on, turn it on and press the **CANCEL** key and recall the message then press the **CALL** key to transmit the message.

### • Error Message ②

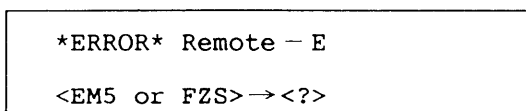

Fig. 2

This means the radiotelephone is now transmitting (it is occupied by other equipment), or the [2182] key is pressed. (example: Tx freq. is set to 2182 by numeric key for FS-1562.)

Suspend transmission of radiotelephone or change Tx frequency from 2182 kHz to another, Press the **CANCEL** key and recall the message then press the **CALL** key to transmit the message.

Note 1: This means the remote function does not operate in good order. If the message can not be transmitted after checking the radiotelephone, execute the following procedure.

Procedure

1. After the error message shown in Fig. 1 appears, set the DSC frequencies at the radiotelephone side manually.
2. Press  key to transmit the message.

Note that the second press of the  key turns the remote function off.

**Remedy for tune error:**

When the  key is pressed, “<TUNE> → <?>” appears on the LCD if tune error is detected. This occurs when the antenna is disconnected, or the transceiver could not be tuned within prescribed tuning time. To transmit message, after connecting the antenna correctly, press the  key and recall the message then press the  key.

# 5. About Internal Battery

---

## Items backed up by battery

- ① Prepared transmit messages  
[] → [] → (Select "MES".)
- ② All received messages ()
- ③ All transmitted messages ()
- ④ Internal clock [] → (Select "TIME".)

## Note

The unit automatically erases all memories shown above if the power is off **for about one month.**