

## SPECIFICATIONS

### GENERAL

Receiving frequency	1575.42 MHz (GPS/Galileo), 1602.5625 MHz (GLONASS), E1B (Galileo), 1OF (GLONASS)
Tracking code	C/A code (GPS), E1B (Galileo), 1OF (GLONASS)
Positional accuracy (dependent on ionospheric activity and multipath)	GPS 10 m approx. (2DRMS, HDOP<4) DGPS 5 m approx. (2DRMS, HDOP<4) WAAS 3 m approx. (2DRMS, HDOP<4) MSAS 7 m approx. (2DRMS, HDOP<4)
Ship's speed accuracy (SOG)	0.02 kn RMS (tracking satellites 5 or more)
Ship's speed accuracy (VBW, SOG)	0.2% of ship's speed or 0.02 kn whichever is the greater (tracking satellites 5 or more, at antenna position)
Course accuracy	SC-130 0.25° RMS, SC-70 0.4° RMS
Course resolution	0.1°, 0.01°, 0.001° (select from menu)
Attitude resolution	0.1°, 0.01°, 0.001° (select from menu)
Rate of turn	0.1°/s, 0.01°/s or 0.001°/s (select from menu)
Tracking bearing	40°/s
Position fixing time	90 s approx. (typical)
Attitude accuracy	Pitch/Roll: 0.4° RMS

### DISPLAY UNIT

Screen	4.3-inch color LCD, 95.04 mm (W) x 87.12 mm (H)
Resolution	480 x 272 dots (WQVGA)
Brilliance	600 cd/m <sup>2</sup> typical
Contrast	17 levels
Display mode	Heading, Nav data, Rate of turn and Speed modes (Non-IMO types only)

### INTERFACE (JUNCTION BOX)

<b>Number of ports (junction box)</b>	
IEC61162-2:	1 port (IN: 1, OUT: 1)
IEC61162-1:	8 ports (IN: 4, OUT: 8)
External beacon input (DATA5 port):	RTCM SC-104 V2.3 (RS-485), ITU-R M823
CANbus:	1 port
AD-10:	4 ports, for heading output
RS-485:	1 port, for display unit connection
LAN (IEC61162-450):	Ethernet, 100Base-TX, RJ45 connector

### Data sentences

DATA ports	Input	ACK, ACM, ACN, HBT, HDT*1, MSK, MSS, THS, VBW*2, VDR*2
	Output	ALC, ALF, ALR, ARC, DTM, GBS, GGA, GLL, GNS, GRS, GSA, GST, GSV, HBT, HDG*2, HDM*2, HDT*1, HRM*2, MSK, POS, RMC, ROT, THS, VBW*2, VDR*2, VHW*2, VLW*2, VTG, XDR*2, ZDA

NETWORK ports	Input	ACK, ACM, ACN, HBT
	Output	ALC, ALF, ALR, ARC, DTM, GBS, GGA, GLL, GNS, GRS, GSA, GST, GSV, HBT, HDG, HDM, HDT*1, HRM*2, POS, RMC, ROT, THS, VBW*2, VDR*2, VHW*2, VLW*2, VTG, XDR*2, ZDA

### Output proprietary sentences

PGN	Input	059392/904, 060928, 061184, 126208/720/996
	Output	059392/904, 060928, 061184, 065280, 126208/464/720/992/996, 127250/251/252/257/258, 129025/026/029/033/044/291/539/540/545/547, 130310/312/314/316/577/578/822/823/842/843/845/846

### IEC61162-450 transmission group

Input	MISC, SATD, NAVD, PROP
	Arbitrary (default: SATD)

### Other network function

NTP, HTTP

\*1: Not used for new SOLAS vessels.

\*2: for Non-IMO types only.

### POWER SUPPLY

Junction box	12-24 VDC: 2.1-1.1 A (included Antenna Unit and Display Unit)
--------------	---

### ENVIRONMENTAL CONDITIONS

Ambient temperature	Antenna unit: -25°C to +55°C (storage: -25°C to +70°C)
	Display unit/ Junction box: -15°C to +55°C
Relative humidity	95% or less at +40°C
Degree of protection	Antenna unit IP56
	Display unit IP22 (IP35: option)
	Junction box IP20 (IP22: bulkhead mount)
Vibration	IEC 60945 Ed.4

### EQUIPMENT LIST

#### Standard

1 Antenna Unit	SC-703 x 1
	SC-1303 x 1
2 Display Unit	SC-702 x 1
3 Junction Box	SC-701 x 1
4 Installation Materials	

#### Optional supply

1 AC/DC Power Supply Unit	PR-240
2 Alarm Monitoring	IF-2503
3 Interface Unit	IF-NMEA SC
4 Remote Display	RD-50
5 Connector (waterproof)	FRU-RJ-PLUG-ASSY
6 Modular Connector	MPS588-C
7 LAN_CNV Kit	OP20-47/48
8 Cable Assembly	M12-05BFFM-010/020/060
9 Connector (NMEA)	LTWMC-05BFFT-SL8001 x 1
	LTWMC-05BMMT-SL8001 x 1
	SS-050505-FMF-TS001 x 1

### DISPLAY UNIT (HANGER)

SC-702 0.7 kg, 1.5 lb

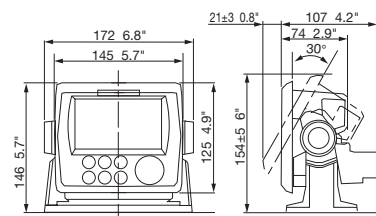

### JUNCTION BOX

SC-701 2.9 kg, 6.39 lb

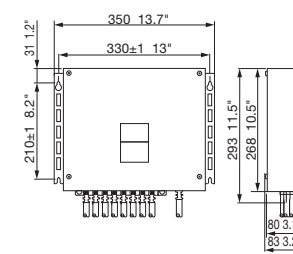

### ANTENNA UNIT

SC-1303 7.1 kg, 15.6 lb

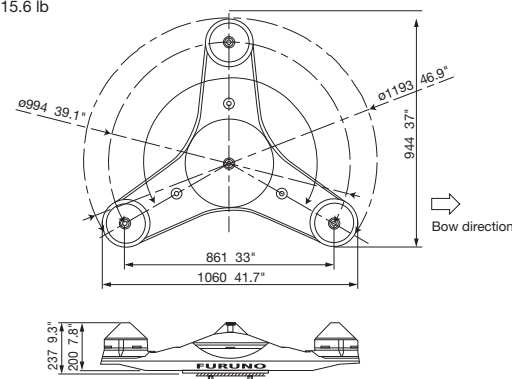

SC-703 2.8 kg, 6.17 lb

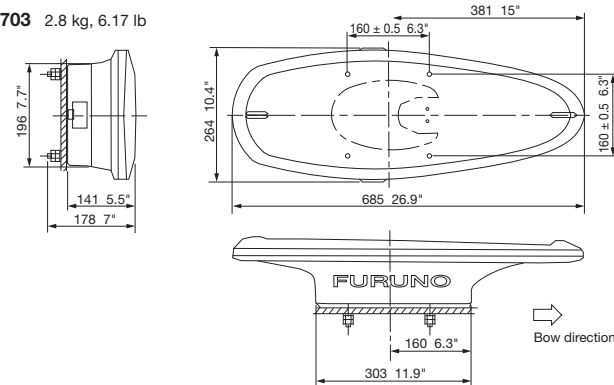

Model

# SC-70/130

GNSS-powered high accuracy compass



Satellite Compass is a trademark of FURUNO ELECTRIC CO.,LTD

Beware of similar products

All brand and product names are registered trademarks, trademarks or service marks of their respective holders.

SPECIFICATIONS SUBJECT TO CHANGE WITHOUT NOTICE

**FURUNO ELECTRIC CO., LTD.**  
Nishinomiya, Hyogo, Japan  
www.furuno.com

**FURUNO U.S.A., INC.**  
Camas, Washington, U.S.A.  
www.furunousa.com

**FURUNO (UK) LIMITED**  
Havant, Hampshire, U.K.  
www.furuno.co.uk

**FURUNO FRANCE S.A.S.**  
Bordeaux-Mérignac, France  
www.furuno.fr

**FURUNO ITALIA S.R.L.**  
Gatteo Mare, Italy  
www.furuno.it

**FURUNO ESPAÑA S.A.**  
Madrid, Spain  
www.furuno.es

**FURUNO DANMARK A/S**  
Hvidovre, Denmark  
www.furuno.dk

**FURUNO NORGE A/S**  
Ålesund, Norway  
www.furuno.no

**FURUNO SVERIGE AB**  
Västra Frölunda, Sweden  
www.furuno.se

**FURUNO FINLAND OY**  
Espoo, Finland  
www.furuno.fi

**FURUNO POLSKA Sp. z o.o.**  
Gdynia, Poland  
www.furuno.pl

**FURUNO EURUS LLC**  
St. Petersburg, Russian Federation  
www.furuno.com.ru

**FURUNO SINGAPORE PTE LTD**  
Singapore  
www.furuno.sg

**FURUNO DEUTSCHLAND GmbH**  
Rellingen, Germany  
www.furuno.de

**FURUNO HELLAS S.A.**  
Piraeus, Greece  
www.furuno.gr

**FURUNO (CYPRUS) LTD**  
Limassol, Cyprus  
www.furuno.com.cy

**FURUNO CHINA CO., LTD.**  
Hong Kong  
www.furuno.com/cn

**FURUNO SHANGHAI CO., LTD.**  
Shanghai, China  
www.furuno.com/cn



1-A-17043SK Printed in Japan  
Catalogue No. CA00001102

# High precision and accurate heading of 0.25° (SC-130) Perfect for Radar, ECDIS, AIS, Sonar and Autopilot



## SATELLITE COMPASS Model SC-70/130

Standard High contrast 4.3" Color LCD  
(on the screen, the THD mode)  
SC-702

The SC-70 and SC-130 are the latest satellite compasses, built on FURUNO's commercial-grade technology platform.

These satellite compasses prove their value by increasing the accuracy of other devices, such as Radar, ARPA, Scanning Sonar, Current Indicator, Chart Plotter, ECDIS and Autopilot.

They provide a highly accurate heading input to these other technologies by utilizing the very latest GNSS (Global Navigation Satellite System). This satellite system is comprised of GPS, Galileo and GLONASS to ensure the highest

precision and a continuous coverage.

The SC-70 and SC-130 provide a variety of data, including GPS Positioning, SOG (Speed Over Ground), COG (Course Over Ground), ROT (Rate Of Turn) and 3-axis speed (bow, stern and longitudinal).

All of these data assist with critical maneuvers, such as berthing.

These compasses are maintenance free and are a great asset for any vessel.

### Features

#### ► SC-130 features a Tri-sensor antenna that provides a high system accuracy for the heading of your vessel

Provides highly accurate heading data for Autopilot, Radar, ARPA, Scanning Sonar, Current Indicator, Chart Plotter, ECDIS and Autopilot.

##### • 0.25° (with SC-130)

Ideal for medium to large vessels navigating in crowded ports and making precise maneuvers, such as berthing.

##### • 0.4° (with SC-70)

Ideal for small to medium boats requiring highly accurate heading.

#### ► Utilizes GNSS such as GPS, Galileo and GLONASS for high Precision

• SBAS compatible (EGNOS, WAAS, MSAS)

• Provide precise data for SOG, COG, ROT and L/L

• Eliminating the problem of not having enough satellites at hand by using multiple types of satellites

#### ► Speed on 3 axis (bow, stern and longitudinal) for safe navigating and berthing

#### ► IMO Type-approved as THD, GPS and ROT. Complying with the IEC, ISO requirements

#### ► Easily integrated into the existing shipboard network via Ethernet

#### ► Rapid follow-up rate 40°/s (twice the IMO high speed craft requirement, 20°/s)

#### ► Maintenance free and no recurring cost as there are no mechanical parts

#### ► Super short starting time - 90 seconds

• Once the power is on, it takes about 90 seconds to start (the starting time will slightly differ depending on the equipment location)

#### ► Easy to retrofit by using existing antenna cabling

• For SC-50/55/60/110/120 (The LAN\_CNV option kit is necessary)

#### ► Precision Pitch/Roll data in Analog and Digital formats for Vessel Stabilization, SONAR, etc.

### Display modes

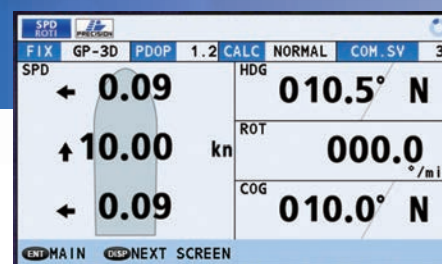

### Navigational data screen

- 3-axis speed, as well as the Heading, Rate Of Turn and Course Over Ground can be grasped at a glance. (non-IMO type only)

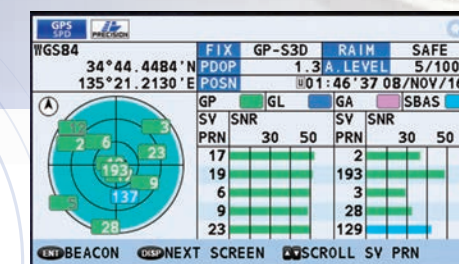

### GPS integrity mode

- GPS satellites signal reception including signal strength and signal to noise Ratio
- SBAS signal status

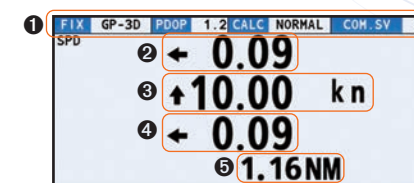

① Current selected mode (SPD or THD), integrity status and common satellite number

② Transverse speed at bow position

③ Longitudinal speed

④ Transverse speed at stern position

⑤ Distance travelled

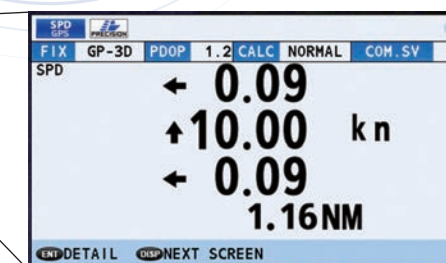

### Speed mode

- 3-axis speed of the ship : bow, stern and longitudinal (non-IMO type only)

### Interconnection Diagram

