

OWNER'S GUIDE &

INSTALLATION INSTRUCTIONS

Transom Mount, 1kW *with* Release Bracket

Depth Transducer

with Temperature Sensor

Model **TM54**

05/23/17

17-299-04 rev. 01

Follow the precautions below for optimal product performance and to reduce the risk of property damage, personal injury, and/or death.

WARNING: Always wear safety goggles and a dust mask when installing.

WARNING: When the boat is placed in the water, immediately check for leaks around the screws and any other holes drilled in the hull.

CAUTION: Never pull, carry, or hold the transducer by the cables as this may sever internal connections.

CAUTION: Never strike the transducer to release it. When mounted on the bracket, remove the transducer by removing the locking pin and hinge pin.

CAUTION: Never use solvents. Cleaner, fuel, sealant, paint and other products may contain solvents that can damage plastic parts, especially the transducer's face.

IMPORTANT: Please read the instructions completely before proceeding with the installation. These instructions supersede any other instructions in your instrument manual if they differ.

Record the information found on the cable tag for future reference.

Part No. _____ Date _____ Frequency _____ kHz

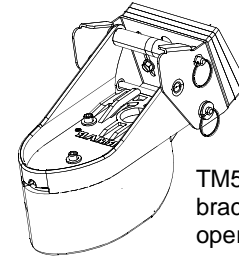

TM54 bracket with shims in operational position

Applications

- Recommended for outboard and inboard/outboard sport fishing powerboats 8m (25') and up
- Not recommended for inboard powerboats
- Not recommended for stepped hulls
- Adjusts to transom angles from 3°–21°
- Bracket protects transducer from frontal impact only

Mounting Location

Guidelines

CAUTION: Do not mount the transducer in line with or near water intake or discharge openings or behind strakes, fittings, or hull irregularities that may disturb the water flow.

CAUTION: Avoid mounting the transducer where the boat may be supported during trailering, launching, hauling, or storage.

- For best performance, the transducer's face must be in contact with smooth water. To identify an area of "clean" water, observe the flow off the transom while the boat is underway.
- Allow space above the bracket for it to release and rotate the transducer upward.
- Mounting on the side of the transom where the propeller blades are moving downward is preferred (see Figure 1).
- Mount the transducer as far away from the propeller as possible ensuring the transducer's face remains in the water when the boat is turning.

Tools & Materials

- Safety goggles
- Dust mask
- Angle finder
- Masking tape (some installations)
- Pencil
- Electric drill
- Drill bits and hole saws:
 - Bracket holes 5mm, #4, or 7/32"
 - Transom hole (optional) 21mm or 13/16"
 - Cable clamp holes 3mm or 1/8"
- Marine sealant (suitable for below waterline)
- Socket wrench
- Straight edge
- Small screwdriver
- Grommet(s) (some installations)
- Cable ties
- Water-based anti-fouling paint (**mandatory in salt water**)

NOTES:

1. To avoid noise interference, it is recommended that the propeller is located outside the transducer beam coverage of 120°.
2. Starboard side of hull where propeller blades are moving downward is preferred.

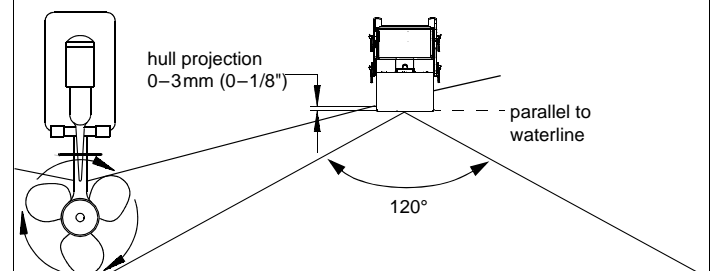

Figure 1. Mounting location on single drive boat

Copyright © 2009 - 2010 Airmar Technology Corp.

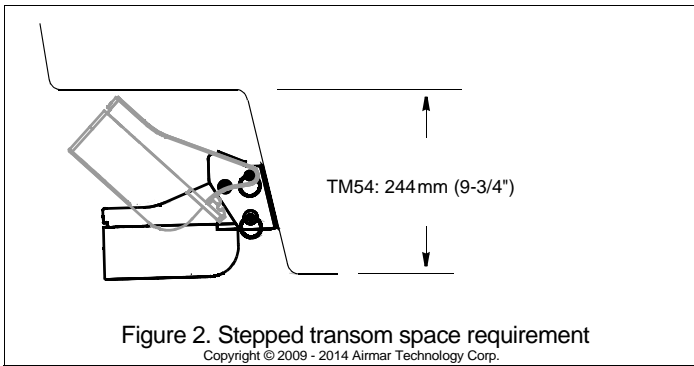

Figure 2. Stepped transom space requirement
Copyright © 2009 - 2014 Airmar Technology Corp.

Boat Types

- **Single drive**—Mount as far away from the propeller as possible ensuring the transducer's face remains in the water when the boat is turning.
- **Twin drive**—Mount between the drives a minimum of 15 cm (6") beyond the swing radius of the propeller.
- **Trim tabs**—Mount inside the trim tab, space permitting.
- **Stepped transom**—Mount the transducer on the lowest step being sure there is enough space above the bracket for it to release and rotate the transducer upward (see Figure 2).

Installation

Assembling the Transducer & Bracket

1. There are two cables. Thread each cable through the corresponding hole in the transducer support (see Figure 3).
2. Fasten the support to the transducer using the three socket-head-cap screws and washers supplied. Tighten the screws with the 3/16" Allen wrench supplied.
3. Attach a safety ring to one end of each pin (see Figure 4).
4. While holding the transducer assembly against the bracket, insert a pin through the *upper* hole in the bracket and the support. Slide the spacer onto the pin and push it through the remaining hole in the support and the bracket. Attach a second safety ring. This pin will function as a hinge when the transducer is released.
5. Slide a washer onto the remaining pin. Push it through the *lower* hole in the bracket, slide it along the channel in the support, and through the second hole in the bracket. Slide the second washer onto the free end of the pin and attach the second safety ring. This will function as the locking pin to hold the transducer in the operational position when underway.

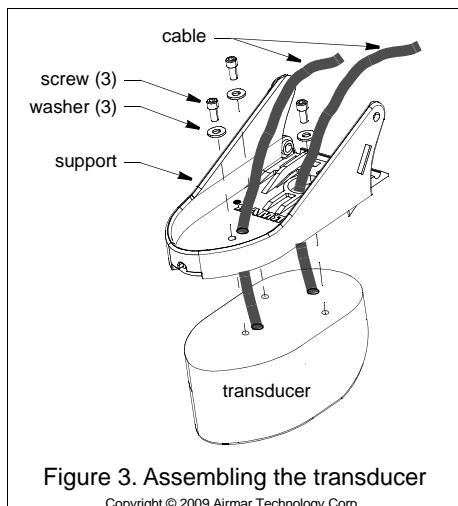

Figure 3. Assembling the transducer
Copyright © 2009 Airmar Technology Corp.

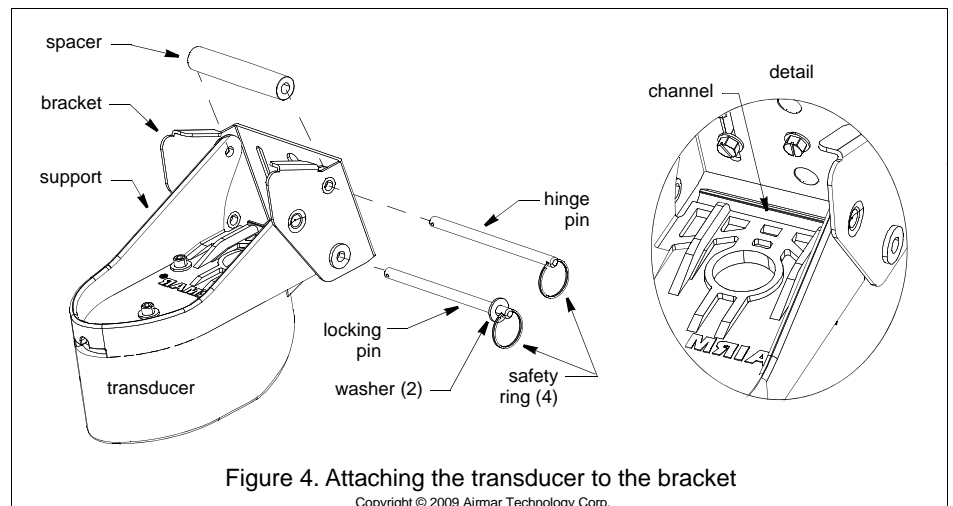

Figure 4. Attaching the transducer to the bracket
Copyright © 2009 Airmar Technology Corp.

Compensating for Transom Angle: Shims

For the best performance, the transducer beam must be aimed straight at the bottom. Since the transom of most boats is angled, the bracket must compensate for it. Measure the transom angle of the boat with an angle finder.

- **Standard transom (12° transom angle)**—The bracket is designed for a standard 12° transom angle. *No shim is needed for this installation.* If your boat is capable of speeds above 20kn (28MPH), install the bracket with one 3° shim, *taper down*. This will ensure that the transducer is in contact with the water at high speeds.
- **Using shims**—The bracket is supplied with three shims; each one has a 3° angle. Up to three shims can be combined for a maximum of 9°. The shims are designed to mate together. Two bosses on the face fit into recesses in the back of another shim or the holes in the bracket.
 - **Transom angles greater than 12°**—Add the appropriate number of shims with the taper up to the 12° bracket angle.
 - **Transom angles less than 12°**—To reduce the bracket's 12° angle, group the appropriate number of shims with the taper down.
- **If you are unsure about using the shim(s)**, experiment with them by following the instructions "Mounting & Adjusting the Bracket."

Hole Drilling

CAUTION: To prevent drilling too deeply, wrap masking tape around the bit 22 mm (7/8") from the point.

NOTE: *Fiberglass hull*—Minimize surface cracking by running the drill in reverse until the gelcoat is penetrated.

1. At the selected mounting location, position the assembly so the transducer projects 3mm (1/8") below the bottom edge of the transom (see Figure 1). Be sure any shim(s) is in place. (You may want to tape the shim(s) to the bracket temporarily.) With the transducer in the operational position, mark the bottom corners of the bracket.
2. Remove the transducer assembly from the bracket by removing the locking pin and the hinge pin (see Figure 4). Hold the bracket with any shim(s) in place against the transom at the marked location. Draw an "X" at 12mm (1/2") from the top and the bottom of each slot (see Figure 6).
3. Using a 5 mm, #4, or 7/32" drill bit, drill four holes 22 mm (7/8") deep at the marked locations.

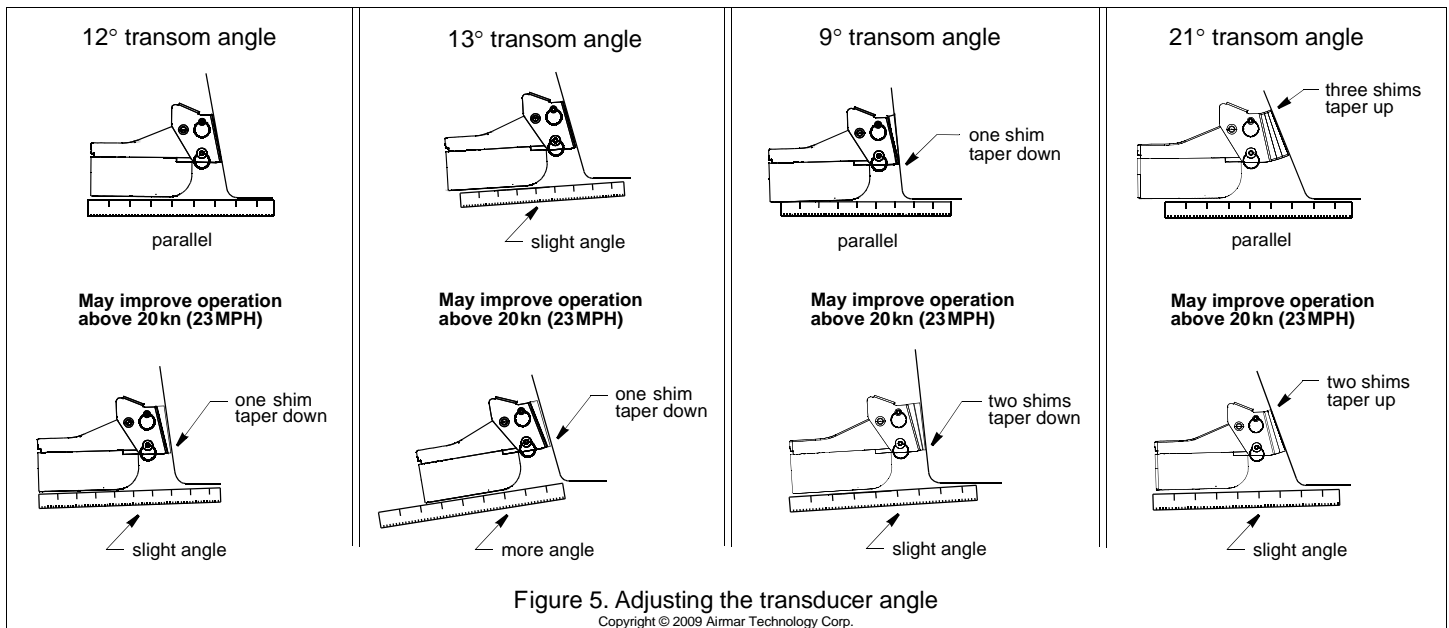

Mounting & Adjusting the Bracket

CAUTION: Do not position the leading edge of the transducer lower than the trailing edge because aeration will occur.

CAUTION: Do not position the transducer deeper in the water than necessary to avoid increasing drag, spray, and water noise and reducing boat speed.

CAUTION: The stainless steel bracket must be isolated from a metal hull to prevent electrolytic corrosion. If no shim is being used, place non-metal insulating washers between the bracket and the metal hull.

1. Apply marine sealant to the threads of four of the hex-washer-head screws to prevent water seepage into the transom. Being sure any shim(s) is in place, screw the bracket to the hull using a socket wrench (see Figure 4). *Do not tighten the screws at this time.*
2. Reinstall the transducer. While holding the transducer assembly against the bracket, insert the hinge pin through the *upper* hole in the bracket and the support. Slide the spacer onto the pin and push it through the remaining hole in the support and the bracket. Reattach the safety ring.
3. Slide a washer onto the locking pin. Push it through the *lower* hole in the bracket, slide it along the channel in the support, and through the second hole in the bracket. Slide the second washer onto the free end of the pin and reattach the safety ring.
4. With the transducer in the operational position, Use a straight edge to sight the underside of the transducer relative to the underside of the hull (see Figure 5). The trailing edge of the transducer should be 1–6mm (1/16–1/4") below the leading edge.

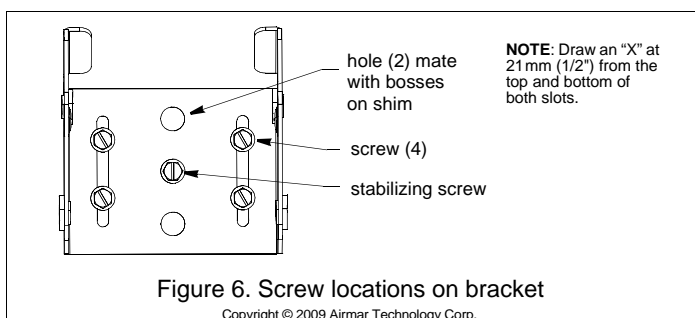

5. Using the vertical adjustment space in the bracket slots, slide the assembly up or down until the bottom inside corner of the transducer projections 0–3mm (0–1/8") below the bottom of the hull (see Figure 1). When you are satisfied with the position of the transducer, tighten the four bracket screws. For clear access to the screws, remove the transducer assembly from the bracket (see Figure 4). *When reattaching, be sure to include the spacer.*

Testing on the Water

1. Test the transducer at 165kHz with the engine off.
2. Become familiar with your echosounder's performance at a speed of 4kn (5 MPH).
3. Gradually increase the boat speed and observe the gradual decline of performance due to turbulent water flowing under the transducer's face.

NOTE: As the speed increases the performance at 50kHz will deteriorate more rapidly because more acoustic noise is generated at low frequencies.

4. If the decline in performance is sudden (not gradual), identify the boat speed at which the onset occurred. Return the boat to this speed, then gradually increase speed while making moderate turns in both directions.
5. If the performance improves while turning to the side on which the transducer is installed, it's position probably needs adjustment. The transducer is probably in turbulent or aerated water.

To improve performance, try the following, one at a time, in the order given.

- a. Increase the transducer's angle in the water. Review "Compensating for Transom Angle: Shims" and see Figure 5.
 - b. Move the transducer deeper into the water in increments of 3mm (1/8") (see Figure 1).
 - c. Move the transducer closer to the centerline of the boat. Fill unused screw holes with marine sealant.
6. **Calibration**—To match the speed shown on the display to the actual speed of the boat, you may need to calibrate the instrument. Refer to your instrument owner's manual.

Stabilizing the Bracket

1. Prevent the bracket from moving out of position using the remaining hex-washer-head screw. Drill the hole for the stabilizing screw through the center hole of the bracket, any shim(s), and the hull (see Figure 6).

2. Apply sealant to the threads of the remaining screw to prevent water seeping into the transom.
3. Fasten the stabilizing screw into place with a socket wrench.
For clear access to the screw, remove the transducer assembly from the bracket (see Figure 4). *When reattaching the transducer, be sure to include the spacer.*

Cable Routing & Connecting

CAUTION: Do not remove the connectors to ease cable routing. If the cables must be cut and spliced, use Airmar's splash-proof Junction Box No. 33-035 and follow the instructions provided. Removing the waterproof connectors or cutting the cables, except when using a water-tight junction box, will void the sensor warranty.

Route the cables over the transom for a detachable installation. For permanent mounting, route the cables through a drain hole or through new holes drilled in the transom **above the waterline**.

1. If holes must be drilled through the transom, choose a location **well above the waterline** (see Figure 7). Check for obstructions such as trim tabs, pumps, or wiring inside the hull. Mark the locations with a pencil. Drill each hole using a 21 mm or 13/16" bit to accommodate the connector.
2. Route the cables over *or* through the transom.
3. On the outside of the hull, secure each cable against the transom using the cable clamps supplied. For the first cable, position one cable clamp 30cm (12") above the bracket. Mark the mounting hole with a pencil.
4. Position the second cable clamp halfway between the first clamp and the cable hole. Mark this mounting hole.
5. If a hole has been drilled through the transom, open the large slot in each transom cable cover. Position a cover over the cable where it enters the hull. Mark the two mounting holes.
6. For the second cable, repeat steps 3, 4, and 5.
7. At each of the marked locations, use a 3mm or 1/8" bit to drill a hole 10mm (3/8") deep.
8. Apply marine sealant to the threads of the #6 x 1/2" self-tapping screws to prevent water from seeping into the transom. If you have drilled holes through the transom, apply marine sealant to the space around the cables where they pass through the transom.
9. Position the four cable clamps and fasten them in place. If used, push a cable cover over each cable and screw them in place.
10. Route the cables to the instrument being careful not to tear the cable jackets when passing it through the bulkhead(s) and other parts of the boat. Use grommet(s) to prevent chafing. To reduce electrical interference, separate the transducer cables from other electrical wiring and the engine(s). Coil any excess cable and secure it in place with cable ties to prevent damage.
11. Refer to your echosounder owner's manual to connect the transducer to the instrument.

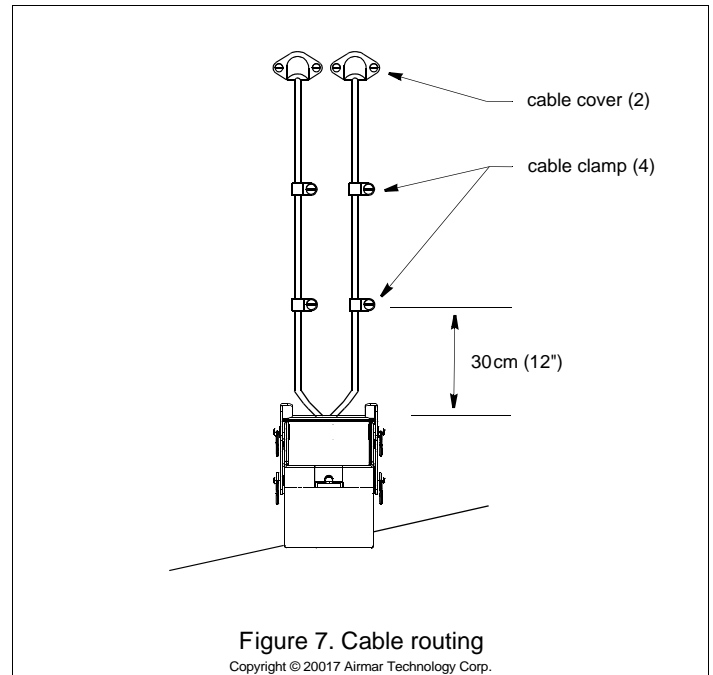

Figure 7. Cable routing

Copyright © 20017 Airmar Technology Corp.

Checking for Leaks

When the boat is placed in the water, **immediately** check for leaks around the screws and any other holes drilled in the hull. Note that very small leaks may not be readily observed. Do not leave the boat in the water unchecked for more than three hours.

Maintenance

Anti-fouling Paint

CAUTION: Do not paint the exposed temperature button. Doing so will slow the sensor's response time.

Aquatic growth can accumulate rapidly on the transducer's face reducing performance within weeks. Surfaces exposed to salt water *that do not interlock* must be coated with anti-fouling paint. Use water-based anti-fouling paint only. Never use ketone-based paint, since ketones can attack many types of plastic possibly damaging the transducer. Repaint every 6 months or at the beginning of each boating season.

Cleaning

CAUTION: Do not use a lubricant on the bracket; grit will stick to it, increasing friction and wear.

Clean the sensor with a Scotch-Brite® scour pad and mild household detergent, taking care to avoid making scratches on the transducer's face. If the fouling is severe, lightly wet sand with fine grade wet/dry paper.

Transducer Replacement & Parts

The information needed to order a replacement transducer is printed on the cable tag. Do not remove this tag. When ordering, specify the part number, date, and frequency in kHz. For convenient reference, record this information on the top of page one.

Lost, broken, and worn parts should be replaced immediately.

Bracket Assembly

33-749-01

Please contact your Furuno dealer to obtain parts.